

DSNR: JPS OPER: SVB SCALE: 1"=10'
 I:\2001\01616\INTERSECTIONS\01616-Intersect Sideroads 1.DGN 6-16-2007 9:28:09 LAST REV: 5-21-2008 BY: svb

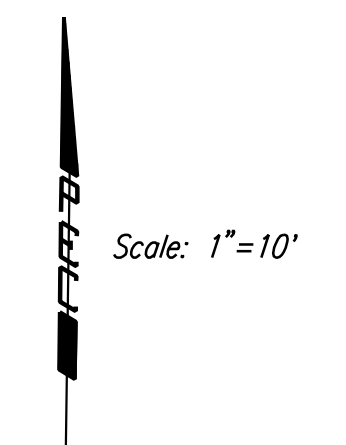
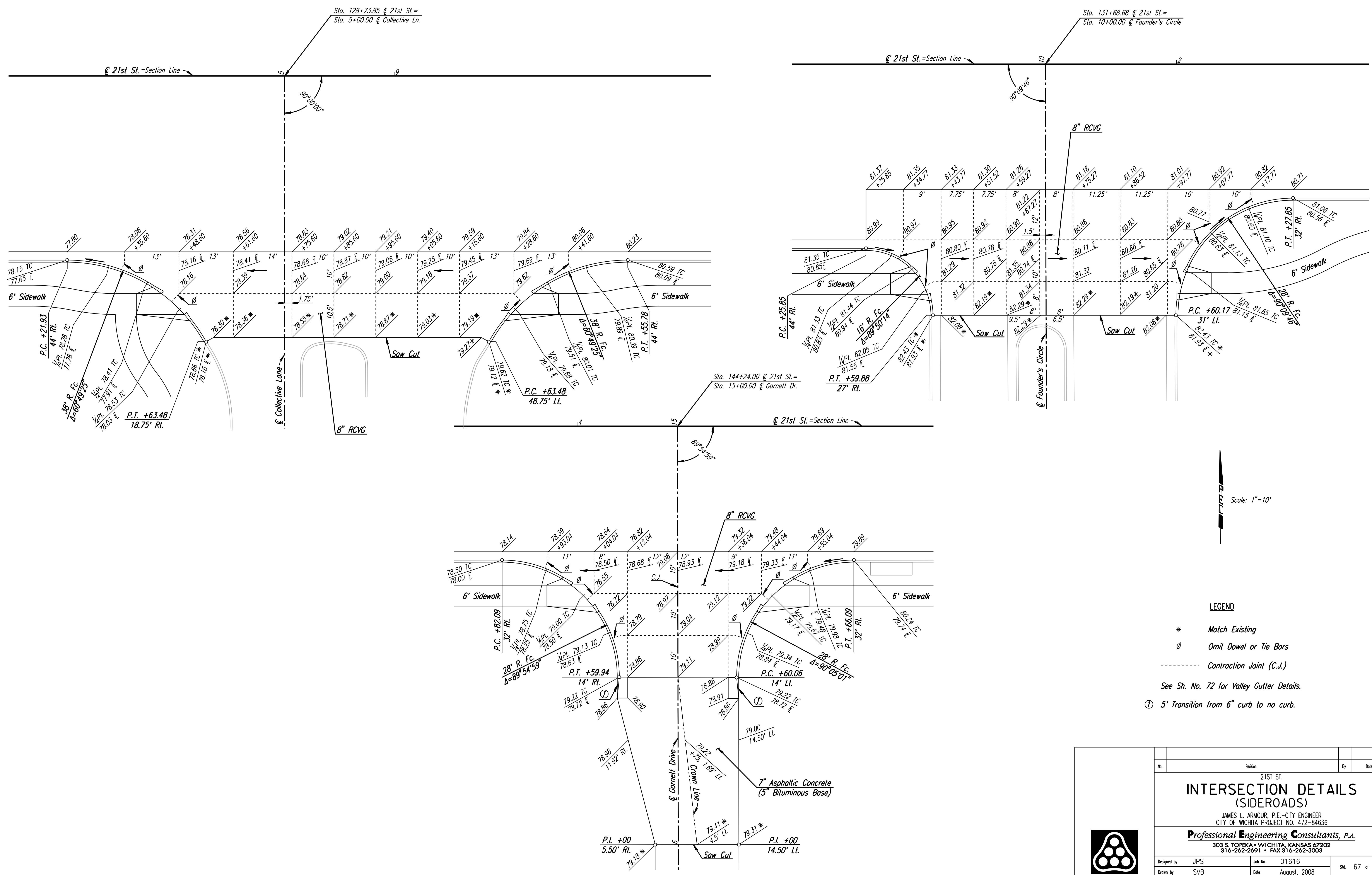

- LEGEND**
- * Match Existing
 - Ø Omit Dowel or Tie Bars
 - Contraction Joint (C.J.)
- See Sh. No. 72 for Valley Gutter Details.
- ① 5' Transition from 6" curb to no curb.

No.	Revision	By	Date
21ST ST.			
INTERSECTION DETAILS (SIDEROADS)			
JAMES L. ARMOUR, P.E. - CITY ENGINEER CITY OF WICHITA PROJECT NO. 472-84636			
Professional Engineering Consultants, P.A. 303 S. TOPEKA • WICHITA, KANSAS 67202 316-262-2691 • FAX 316-262-3003			
Designed by	JPS	Job No.	01616
Drawn by	SVB	Date	August, 2008
			Sht. 67 of 282