

DSNR: MSN OPER: MSN SCALE: 1:2001/01616/RCB/01616-General_Notes_3-8x5.dgn 01-17-2008 16:00:00 LAST REV: 5-21-2008 BY: svb

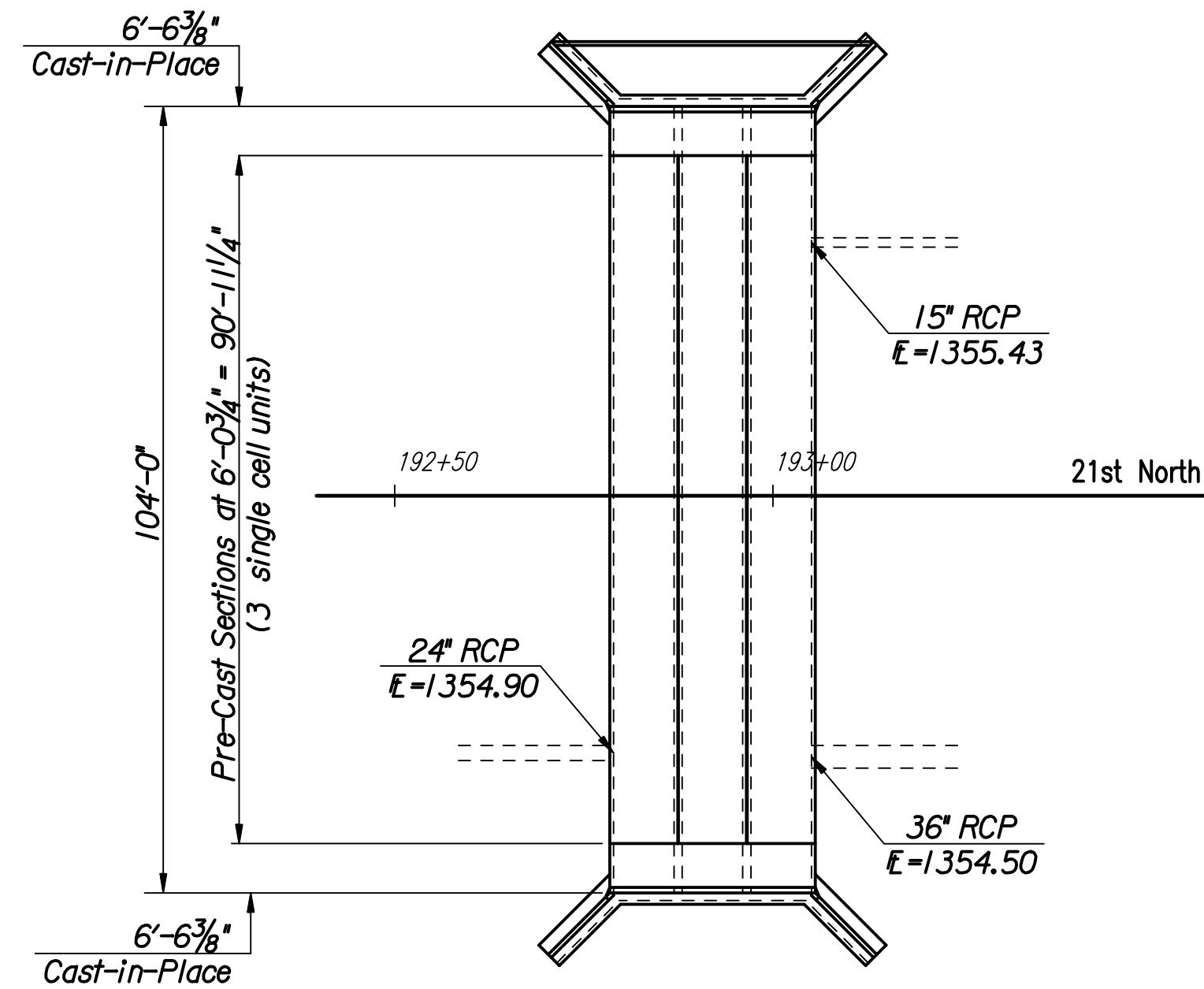
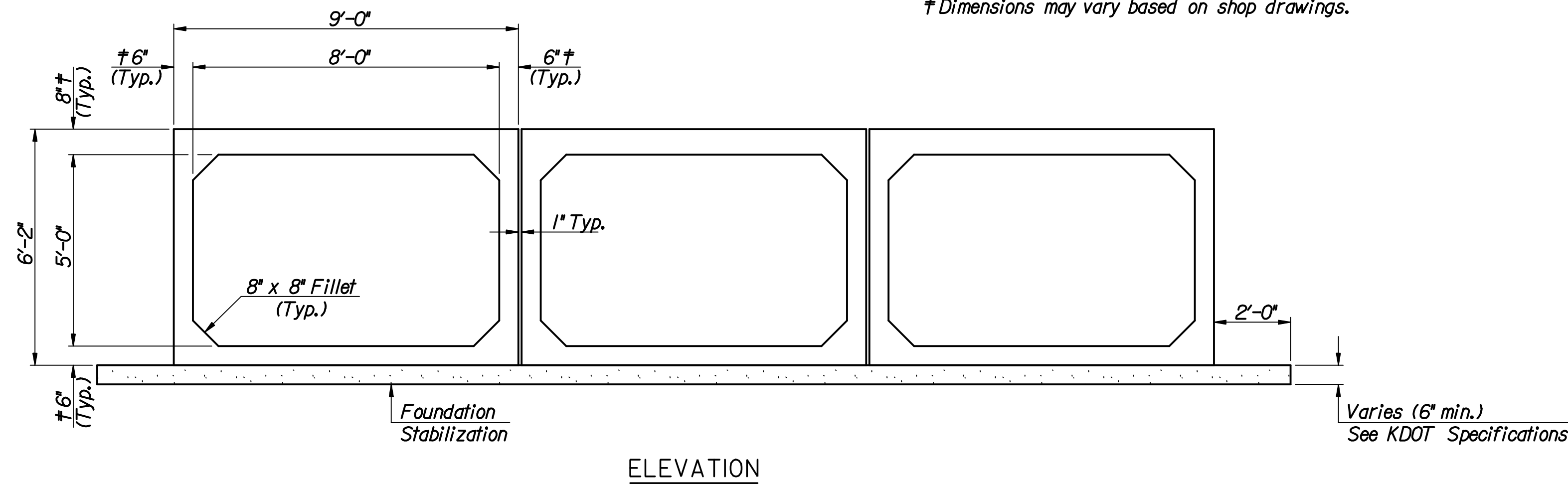

GENERAL NOTES

LOADING: HS20-44 A.A.S.H.T.O. Specification, 1983 Edition.

UNIT STRESSES:
Concrete $F'_c = 4000$ p.s.i. $F_y = 60,000$ p.s.i.
 $F_c = 1600$ p.s.i. $F_s = 24,000$ p.s.i.

CONSTRUCTION: The Contractor shall construct the "3-8'x5' RCB" as shown. Details depict pre-cast construction with cast-in-place end units and cast-in-place wingwalls.

JOINTS: Construction Joints shall only be formed at locations shown or as approved by the Engineer.

EXCAVATION: All excavation and backfill shall extend two (2) feet beyond the sides of the box and wingwall.

CONFLICT: If R.C.B. plan notes conflict with the General Notes from this sheet, then these General Notes will govern.

Specific notes for Cast-in-Place end units are provided on the R.C.B. Details sheets.

PAYMENT: The "3-8'x5' RCB" shall bid per the summary of quantities as shown. Payment shall include all labor and all other incidentals necessary to complete the work.

PRECAST CONCRETE: Precast Box Sections shall meet the appropriate design and inspection requirements of A.S.T.M. Designation C-850, Table 2 or C-789, Table 2 whichever is critical and the Loading Specifications. The intermediate joints shall be sealed with a mastic compound which shall be provided for approval with the shop detail submittal. The Contractor shall furnish, to the Engineer, detail plans and shop drawings showing the proposed precast layout and all other details for manufacture and delivery of any precast items to be incorporated into the work. Doweling details between pre-cast and cast-in-place ends must be submitted for approval by the Engineer.

FOUNDATION STABILIZATION: The Foundation Stabilization quantity has been calculated to the limits shown on the "RCB Auxiliary Details" sheet. The depth may be increased by the Engineer. The Contractor may underrun Foundation Stabilization under the barrel if founded on firm material and with the Engineer's approval. Use Foundation Stabilization on all wingwalls unless founded on rock or granular material.

SUMMARY OF QUANTITIES	
Precast Box (8'-0"x5'-0")	272.8 L.F.
Concrete (Grade 4.0)	54.1 C.Y.
Reinforcing Steel (Gr. 60)	7230 Lbs.
Class III Excavation	135 C.Y.
Foundation Stabilization	70 C.Y.

No.	Revision	By	Date
21ST ST.			
GENERAL NOTES			
3-8'x5' RCB STA. 192+92.00			
JAMES L. ARMOUR, P.E. - CITY ENGINEER CITY OF WICHITA PROJECT NO. 472-84636			
Professional Engineering Consultants, P.A. 303 S. TOPEKA • WICHITA, KANSAS 67202 316-262-2691 • FAX 316-262-3003			
Designed by	MSN	Job No.	01616
Drawn by	MSN	Date	August, 2008
			Sht. 98 of 282