

STATE	PROJECT NO.	YEAR	SHEET NO.	TOTAL SHEETS
KANSAS	472-84748	2008	25	52
KDOT PROJECT NO. 87 N-0429-01				

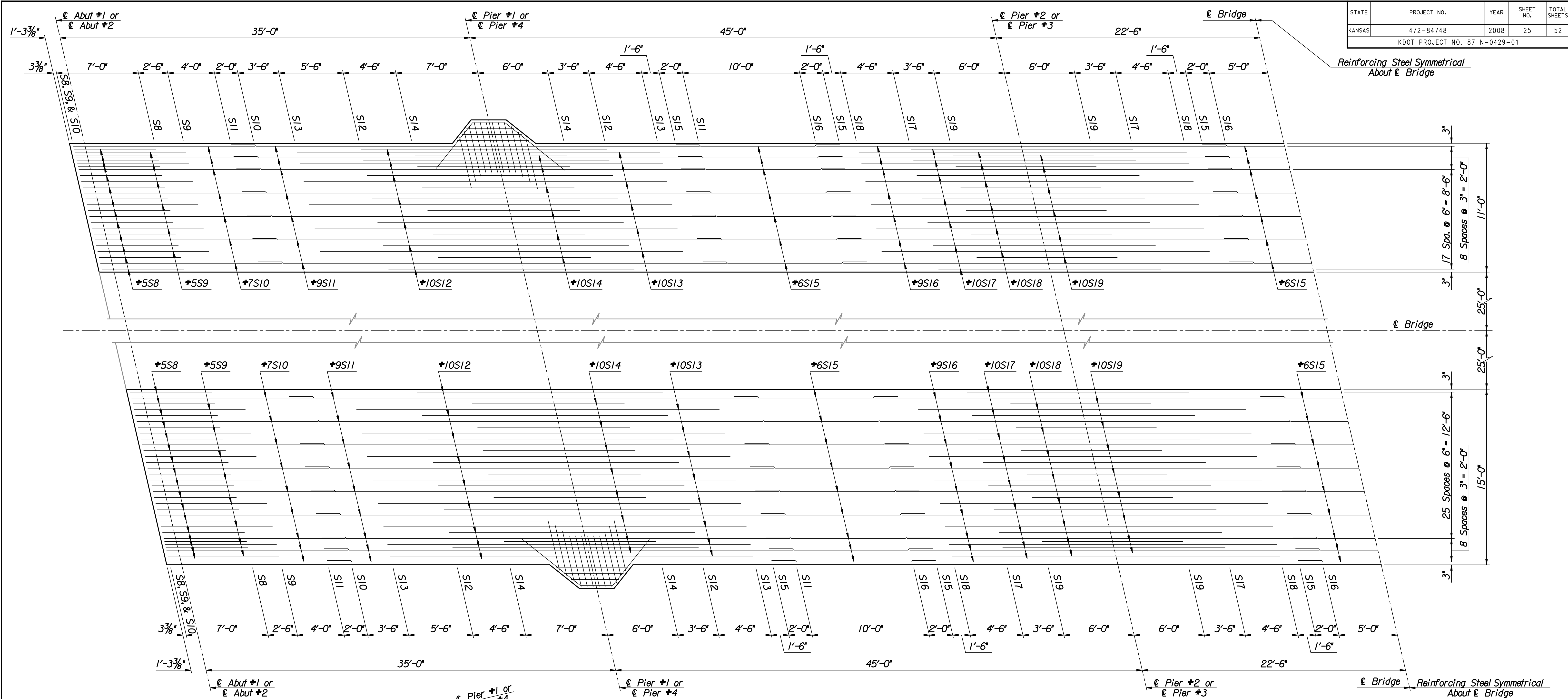

TOP SLAB PLAN
(WIDENING)

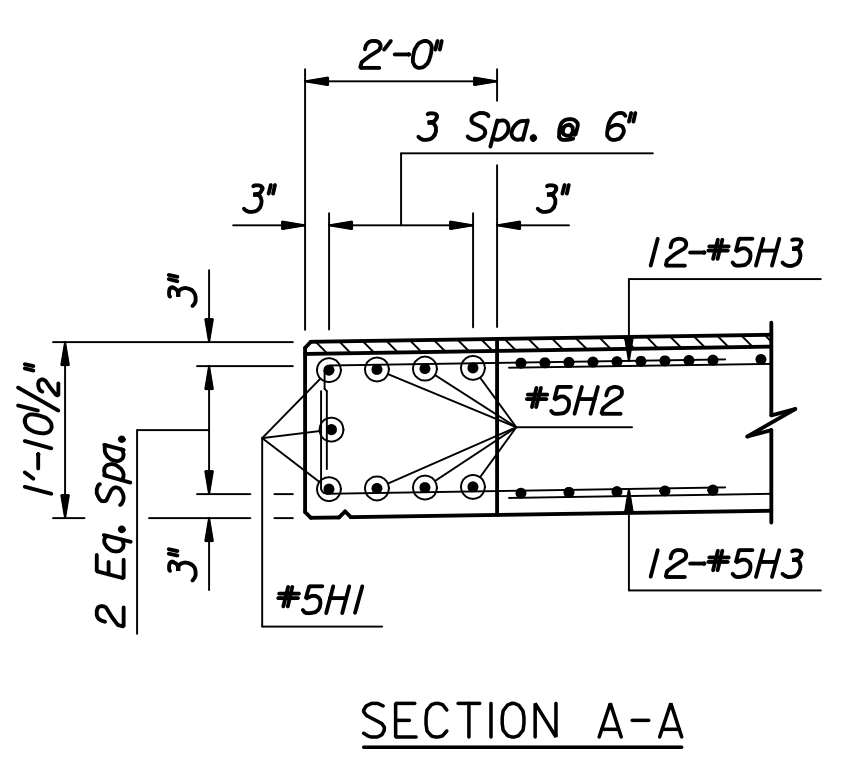

SECTION A-A

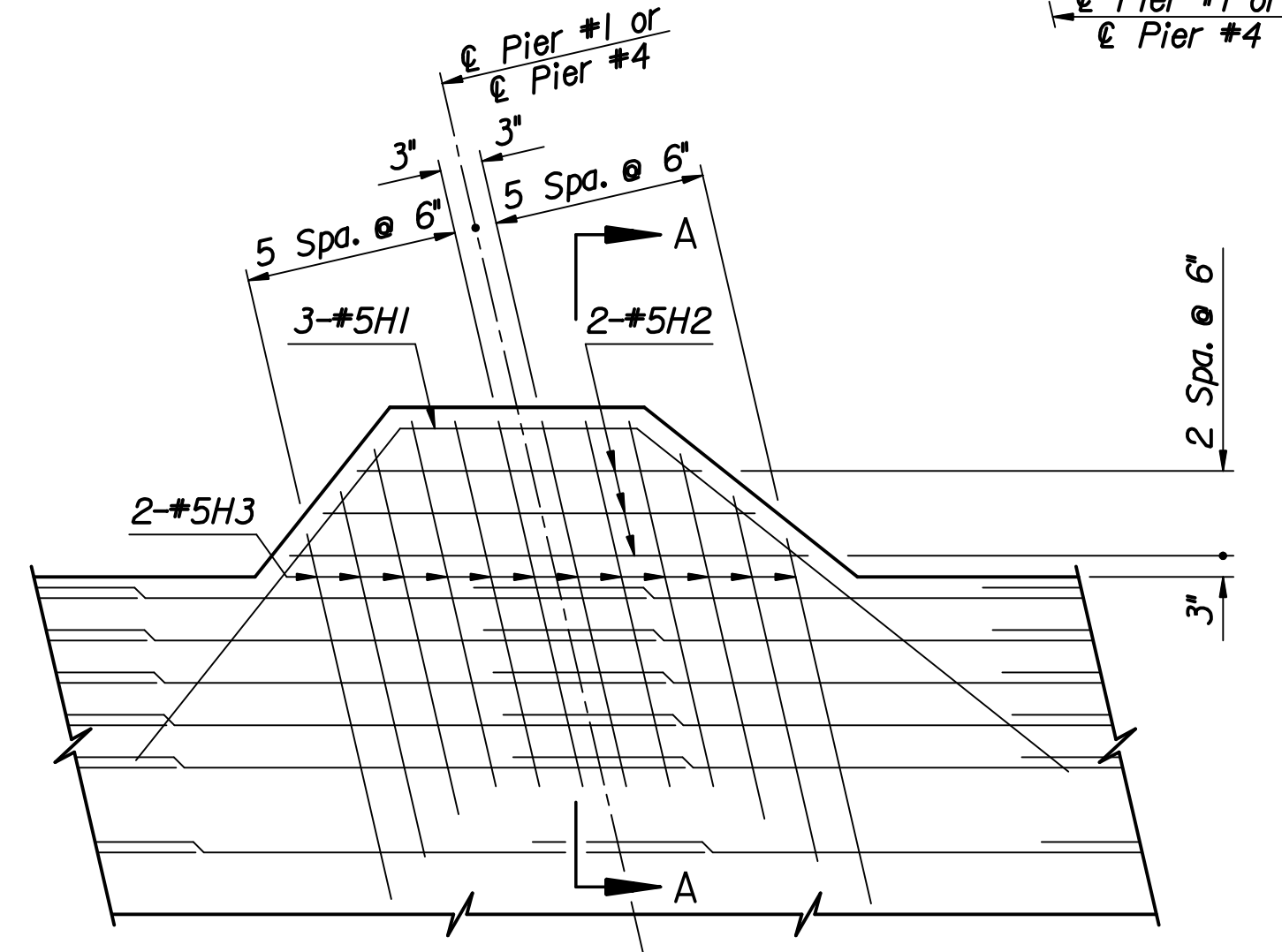

SLAB EXTENSION PLAN
Showing Reinforcing Steel

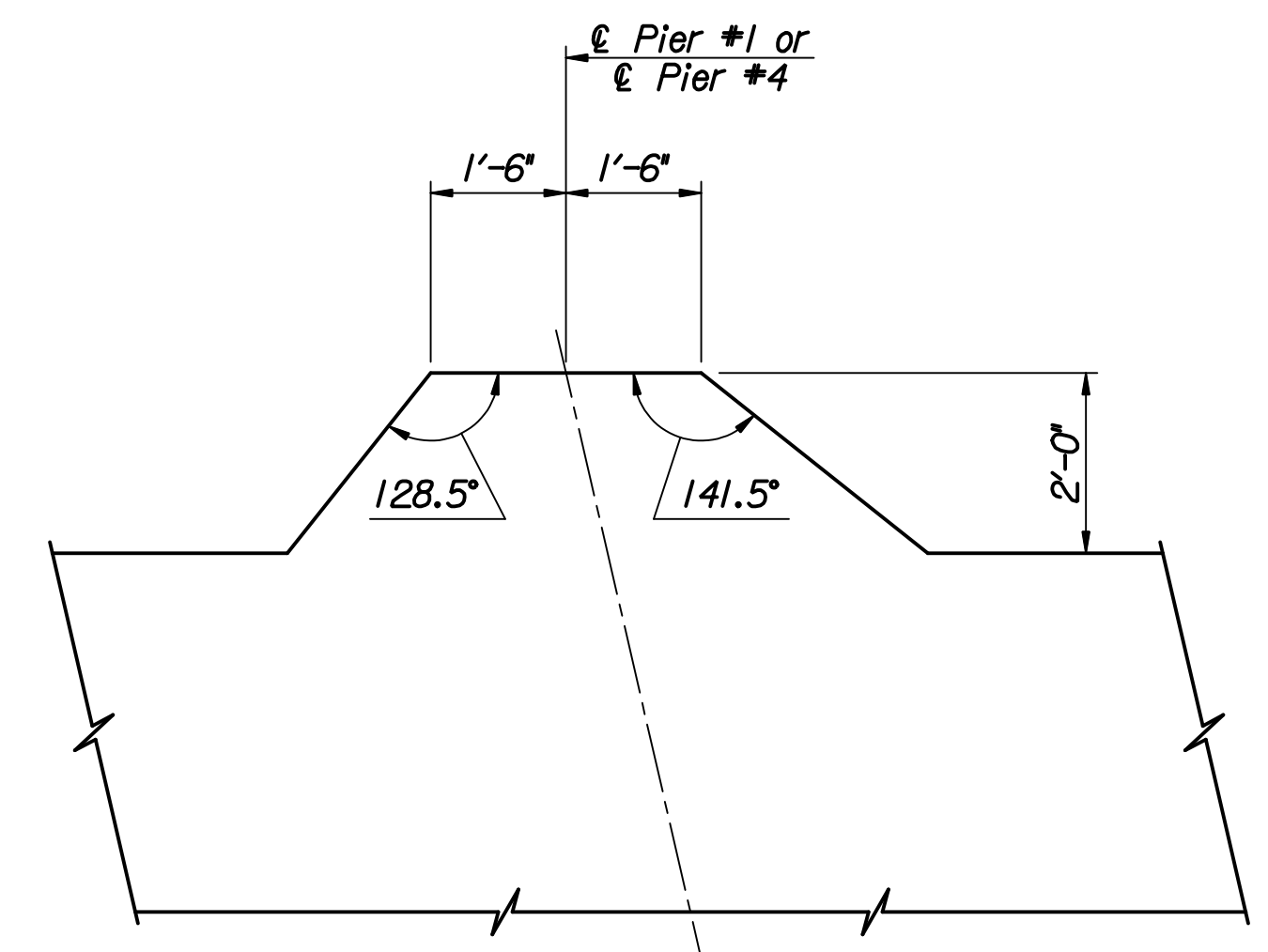

SLAB EXTENSION PLAN
Dimensional Control

No.	Revisions	By	Date
CITY OF WICHITA BR. NO. 430400876500010 STA. 17+62.50 PROPOSED SUPERSTRUCTURE LAYOUT 21ST STREET OVER LAR PROJECT NO. 472-84748 SEDGWICK COUNTY			
Professional Engineering Consultants, P.A. 303 S. TOPPEKA • WICHITA, KANSAS 67202 316-262-2691 • FAX 316-262-3003			
Designed by	M.S.N.	Checked by	R.A.S.
Drawn by	M.S.N.	Date	Feb. 2007
		Job No.	06009

Plotted by : msn 9-2-2008
 Drawn by : msn
 I:\2006\06009\Final\09_02_2008\06009-000-SSdetail\slabTop.dgn