

RIPRAP INFORMATION STR. NO. 530400870LAR100							
ABUTMENT #1 Northwest				ABUTMENT #2 Northeast			
POINT	STATION	OFFSET	ELEVATION	POINT	STATION	OFFSET	ELEVATION
1	68+29.79	40.00' Lt.	125.2	1	70+56.16	40.00' Lt.	124.2
2	68+73.19	40.00' Lt.	112.5	2	70+10.82	40.00' Lt.	111.9
3	68+78.71	23.00' Lt.	110.7	3	70+16.34	23.00' Lt.	111.9
4	68+46.34	23.00' Lt.	123.2	4	70+48.71	23.00' Lt.	123.2
5	68+41.79	37.00' Lt.	123.2	5	70+44.16	37.00' Lt.	123.2
6	68+29.79	37.00' Lt.	125.2	6	70+56.16	37.00' Lt.	124.2

RIPRAP INFORMATION STR. NO. 530400870LAR100							
ABUTMENT #1 Southwest				ABUTMENT #2 Southeast			
POINT	STATION	OFFSET	ELEVATION	POINT	STATION	OFFSET	ELEVATION
1	68+53.84	40.00' Rt.	125.3	1	70+80.21	40.00' Rt.	124.9
2	68+99.18	40.00' Rt.	110.6	2	70+36.81	40.00' Rt.	112.6
3	68+93.66	23.00' Rt.	109.9	3	70+31.29	23.00' Rt.	112.6
4	68+61.29	23.00' Rt.	121.9	4	70+63.66	23.00' Rt.	120.9
5	68+65.84	37.00' Rt.	121.9	5	70+68.21	37.00' Rt.	120.9
6	68+53.84	37.00' Rt.	125.3	6	70+80.21	37.00' Rt.	124.9

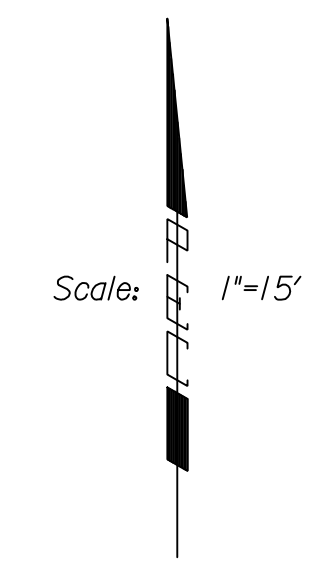
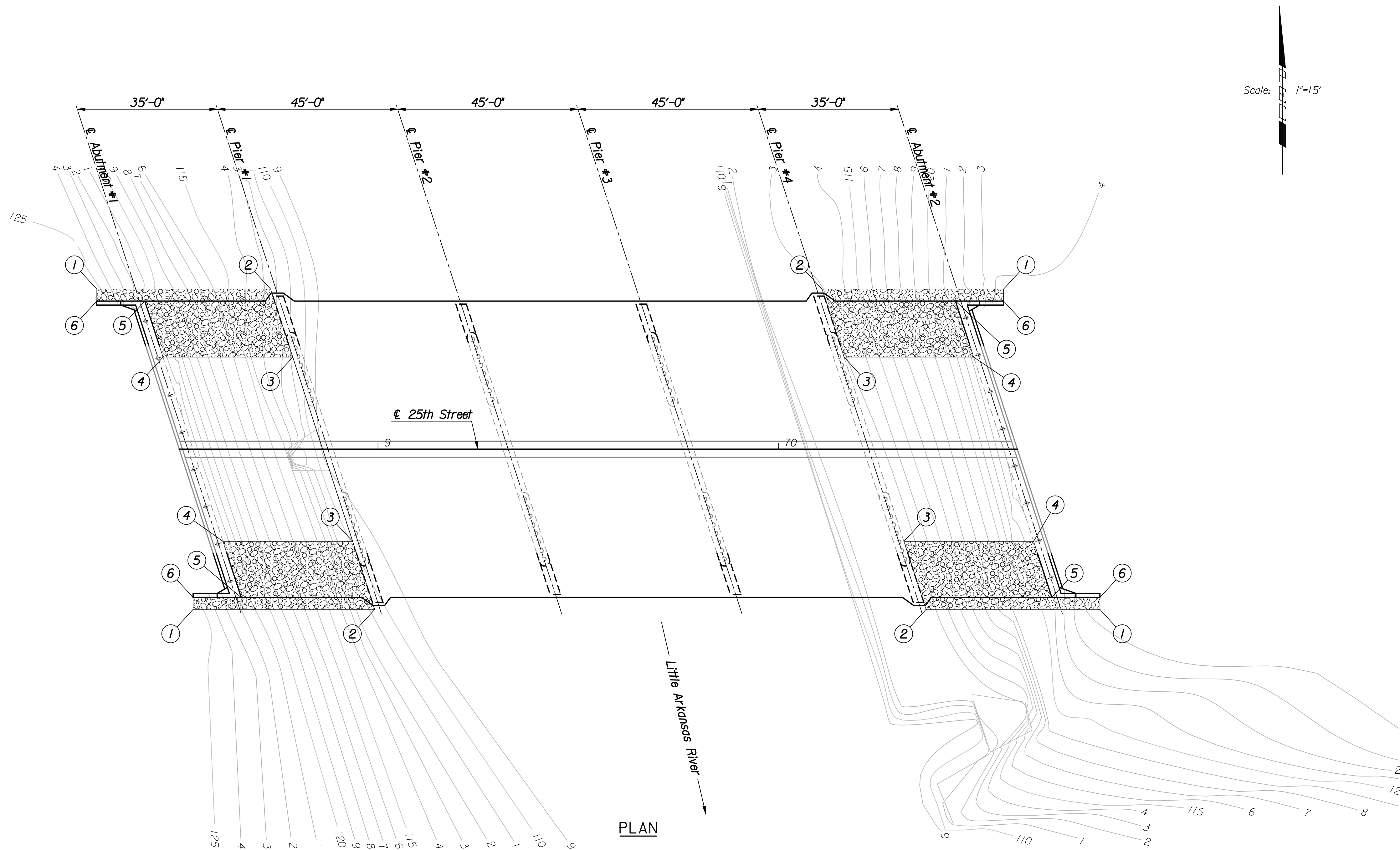

Plotted by : msn 9-3-2008
 Drawn by : will
 I:\2006\06008\Final\09_02_2008\06008-000-Riprap.dgn

Riprap (Light Stone)

No.	Revisions	By	Date
CITY OF WICHITA BR. NO. 530400870LAR100 STA. 69+55.00 PROPOSED RIPRAP 25TH STREET OVER LAR PROJECT NO. 472-84595 SEDGWICK COUNTY			
 Professional Engineering Consultants, P.A. 303 S. TOPEKA • WICHITA, KANSAS 67202 316-262-2691 • FAX 316-262-3003			
Designed by	M.S.N.	Checked by	R.A.S.
Drawn by	W.L.L.	Date	April 2008 Job No. 06008