

STATE	PROJECT NO.	YEAR	SHEET NO.	TOTAL SHEETS
KANSAS	472-84595	2008	33	43
KDOT PROJECT NO. 87 N-0360-01				

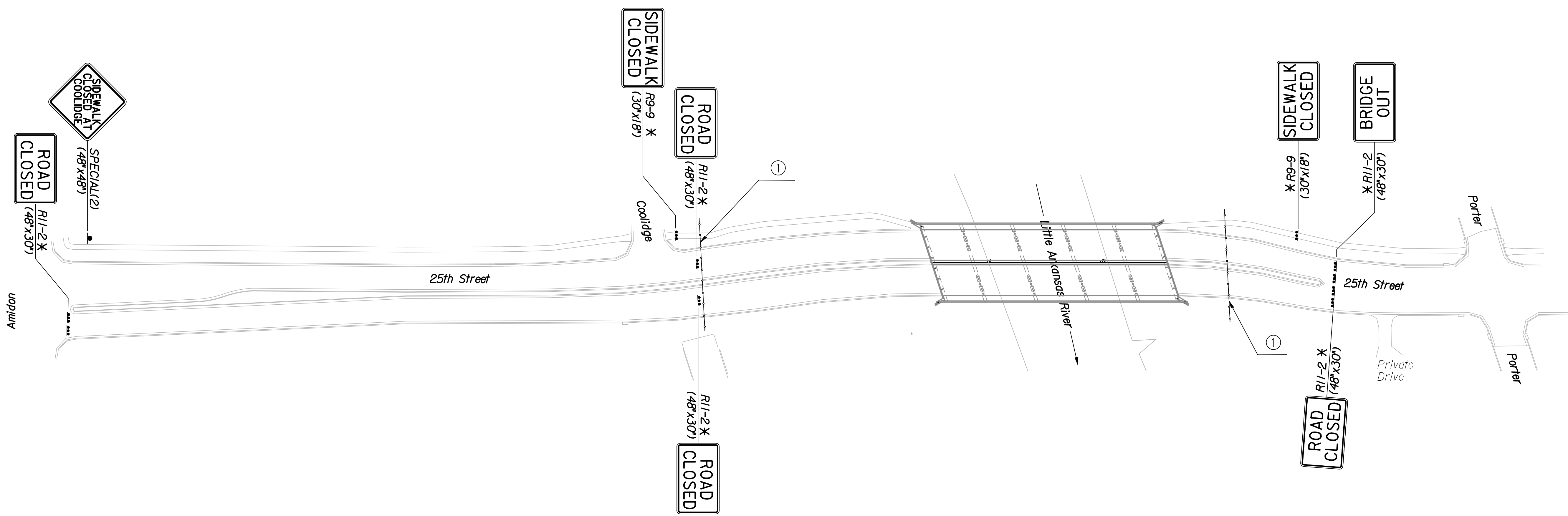
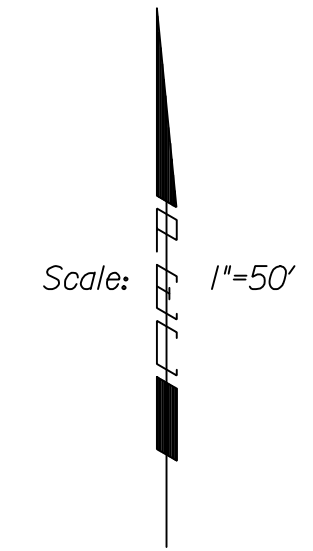

- LEGEND**
- \*\*\* Type III Barricade with Type A Low Intensity Flashing Warning Lights.
  - \* Sign to be mounted on Type III Barricade
  - ① 100 L.F. Snow Fence on T-Posts.

Plotted by : msn 9-3-2008  
 Drawn by : will  
 I:/2006/06008/final/09\_02\_2008/06008-000-Traffic-Control.dgn

No.	Revisions	By	Date
<b>CITY OF WICHITA</b> BR. NO. 530400870LARI00 STA. 69+55.00 <b>TRAFFIC CONTROL PLAN</b> <b>25TH STREET OVER LAR</b> PROJECT NO. 472-84595 SEDGWICK COUNTY			
<b>Professional Engineering Consultants, P.A.</b> <small>303 S. TOPEKA • WICHITA, KANSAS 67202          316-262-2691 • FAX 316-262-3003</small>			
Designed by	M.S.N.	Checked by	R.A.S.
Drawn by	M.S.N.	Date	April 2008 Job No. 06008