

STATE	PROJECT NO.	YEAR	SHEET NO.	SHEETS
KANSAS	87 N-0357-01	2008	52	185

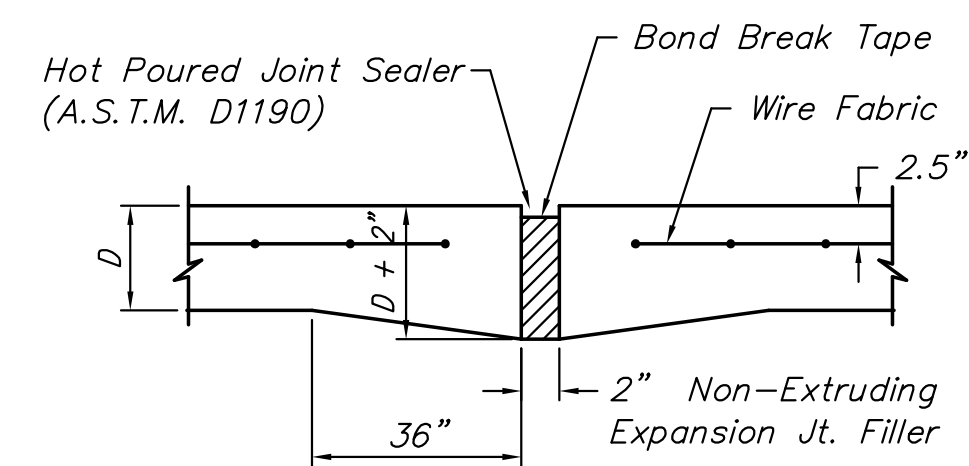

**EXPANSION JOINT**

NOTE: Extra Thickness to be Subsidiary to Price of Square Yards Pavement

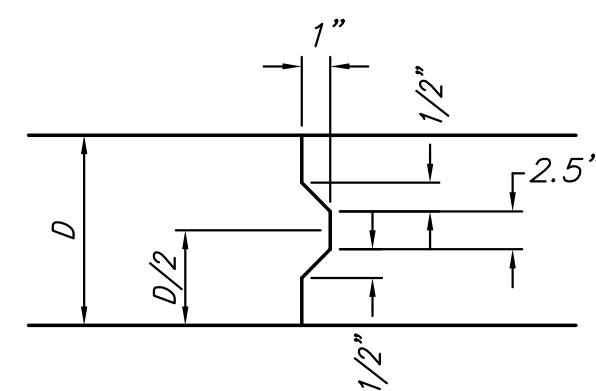

**KEYWAY DETAIL**

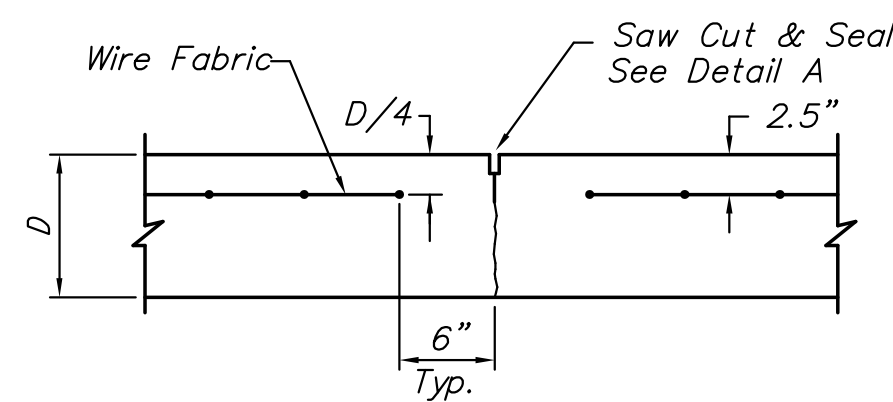

**CONTRACTION JOINT DETAIL (C.J.)**

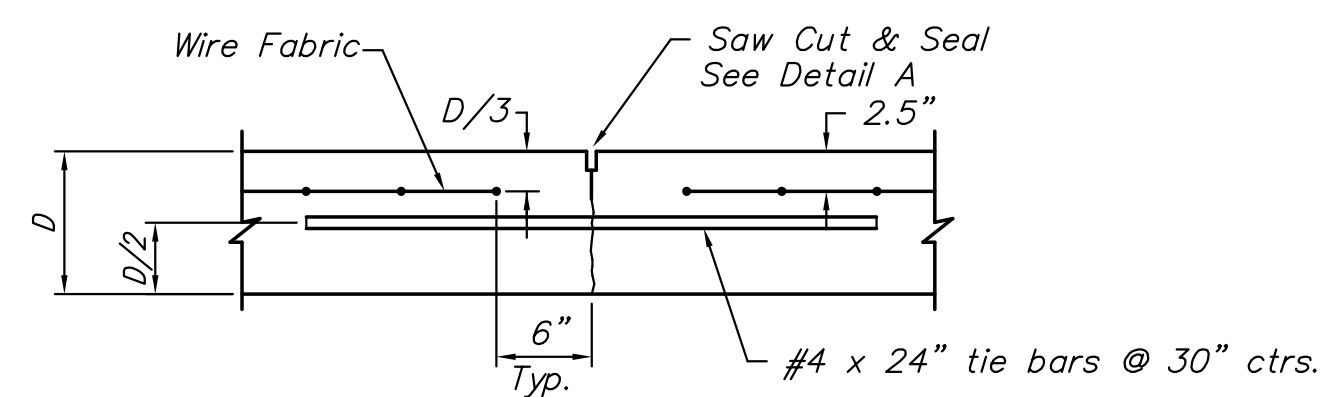

**LONGITUDINAL JOINT DETAIL (L.J.)**

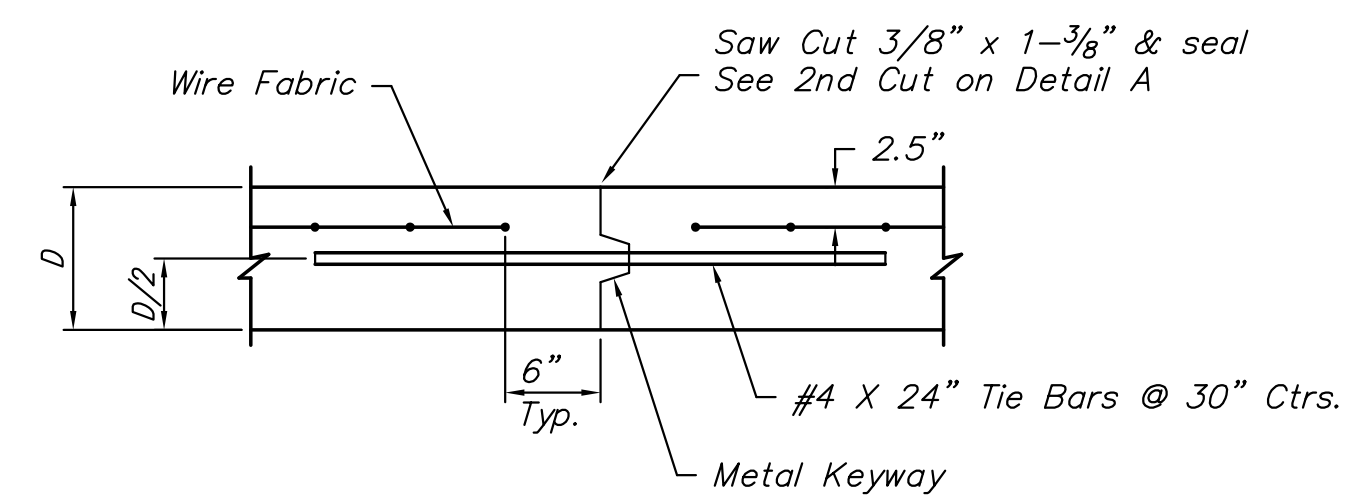

**OPTIONAL LONGITUDINAL JOINT DETAIL (L.J.)**

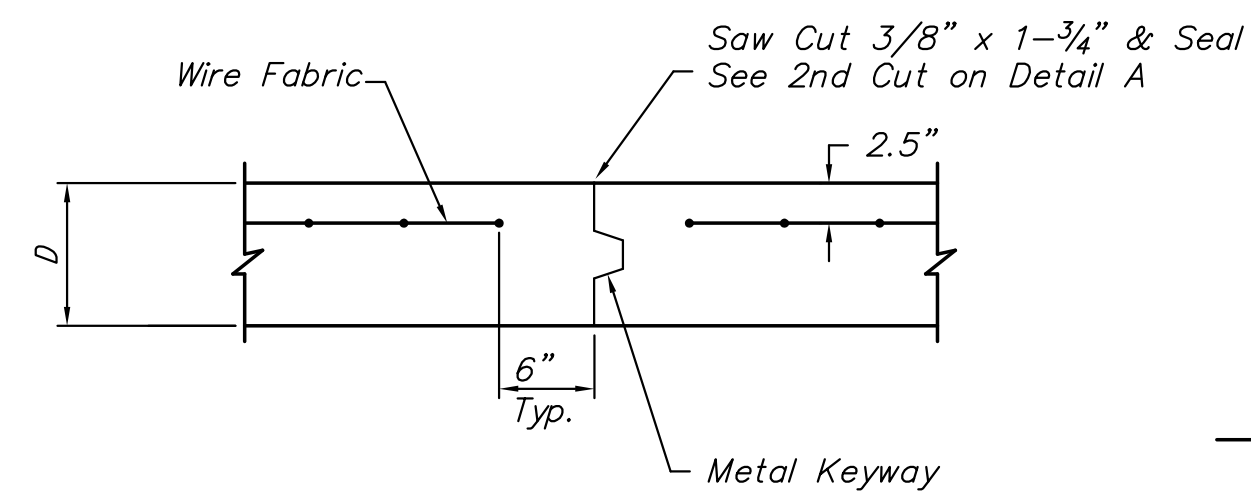

**OPTIONAL CONTRACTION JOINT**

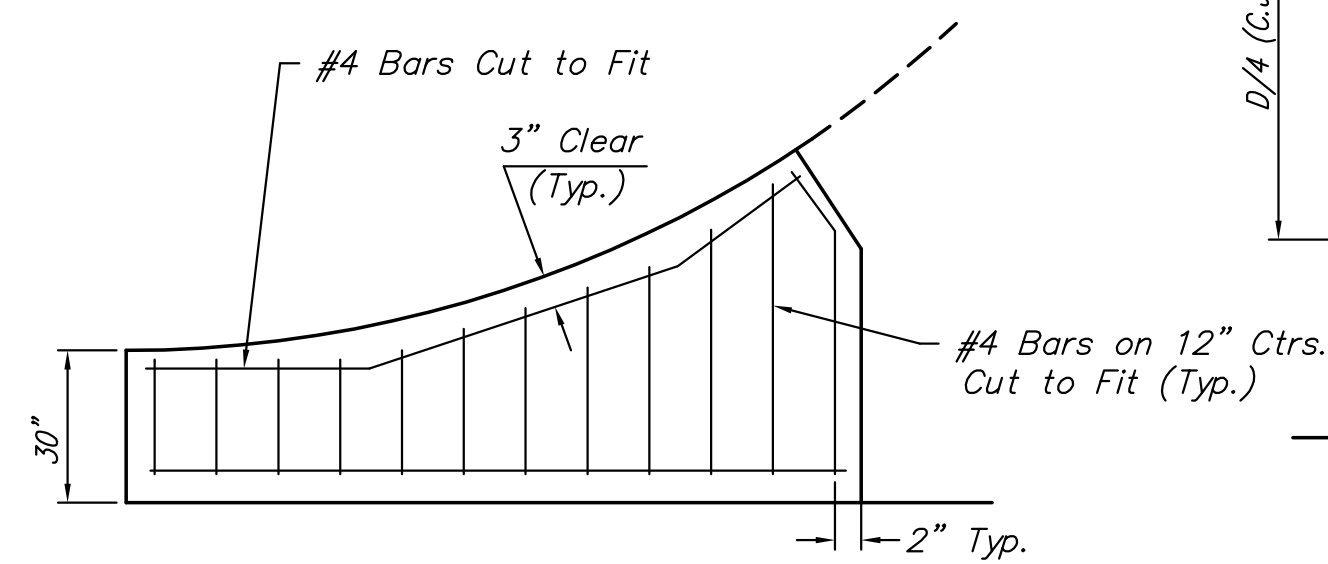

**WING REINFORCING DETAIL**

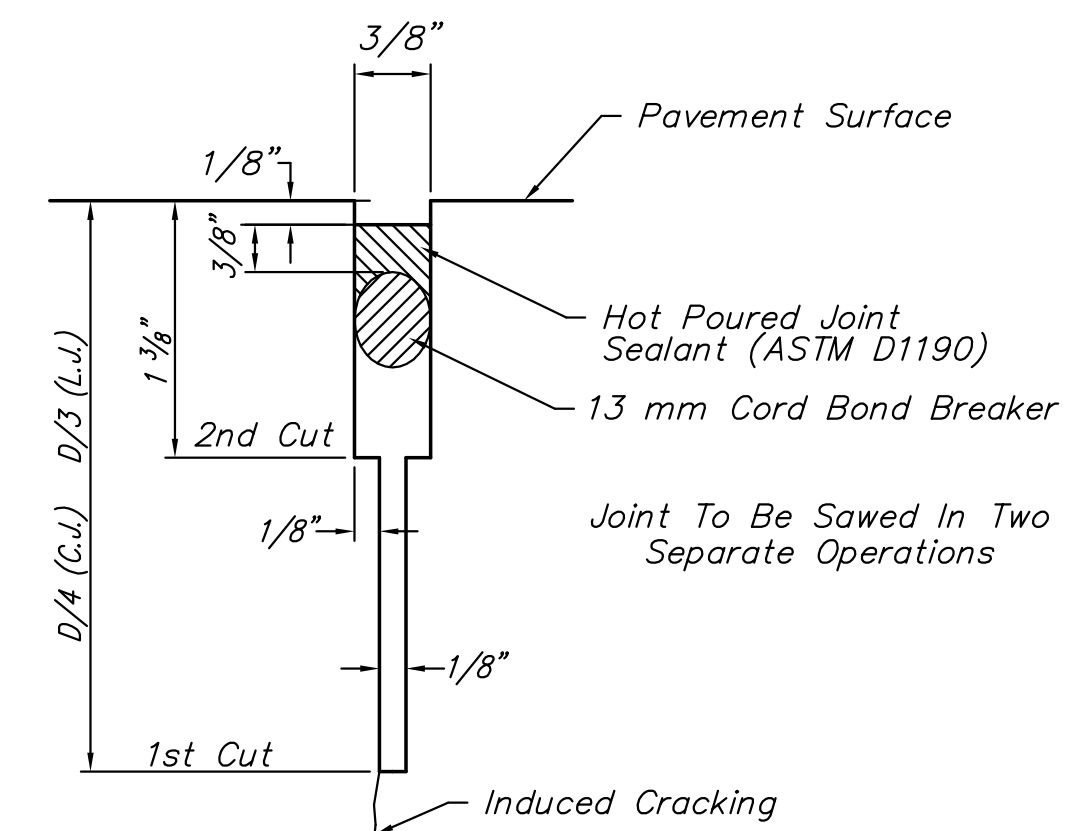

**SAW JOINT DETAIL**

D = 8"

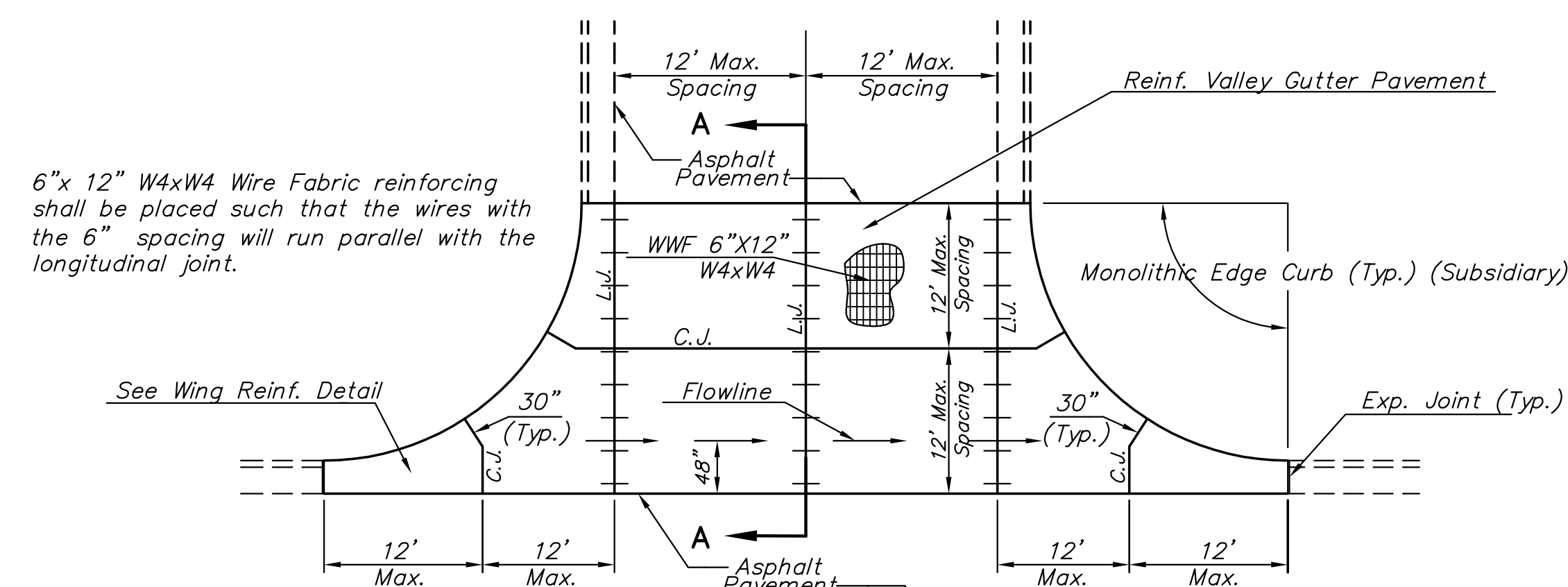

**PLAN**

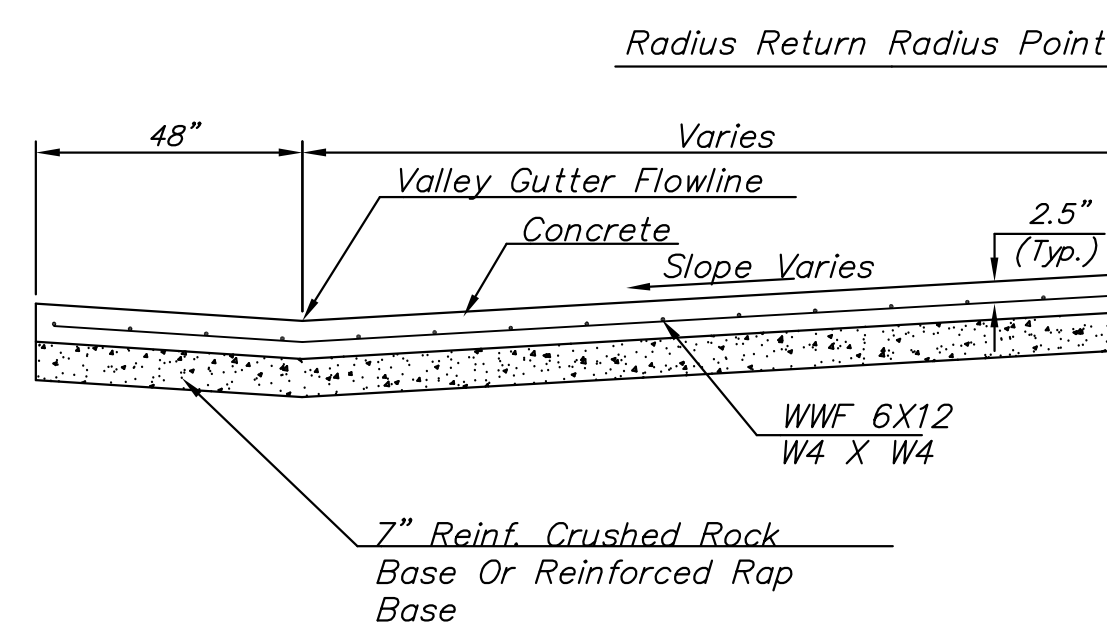

**SECTION A-A**

**REINFORCED VALLEY GUTTER DETAIL**

J:\Civil\04221\dwg\details\04221dd3.dwg 10/23/2007 04:47:19 PM CST

KANSAS DEPARTMENT OF TRANSPORTATION

**OLIVER IMPROVEMENTS  
VALLEY GUTTER DETAILS**

PROJECT NO. 87 N-0357-01 SEDGWICK CO.

**M K E C ENGINEERING CONSULTANTS, INC.**  
WICHITA, KANSAS

DESIGNED BY: JRA	CHECKED BY: JRA
DRAWN BY: JSB	DATE: DEC. 2005 SHEET 52 OF 185