

BANDED SIGN MOUNTING BRACKET DETAIL

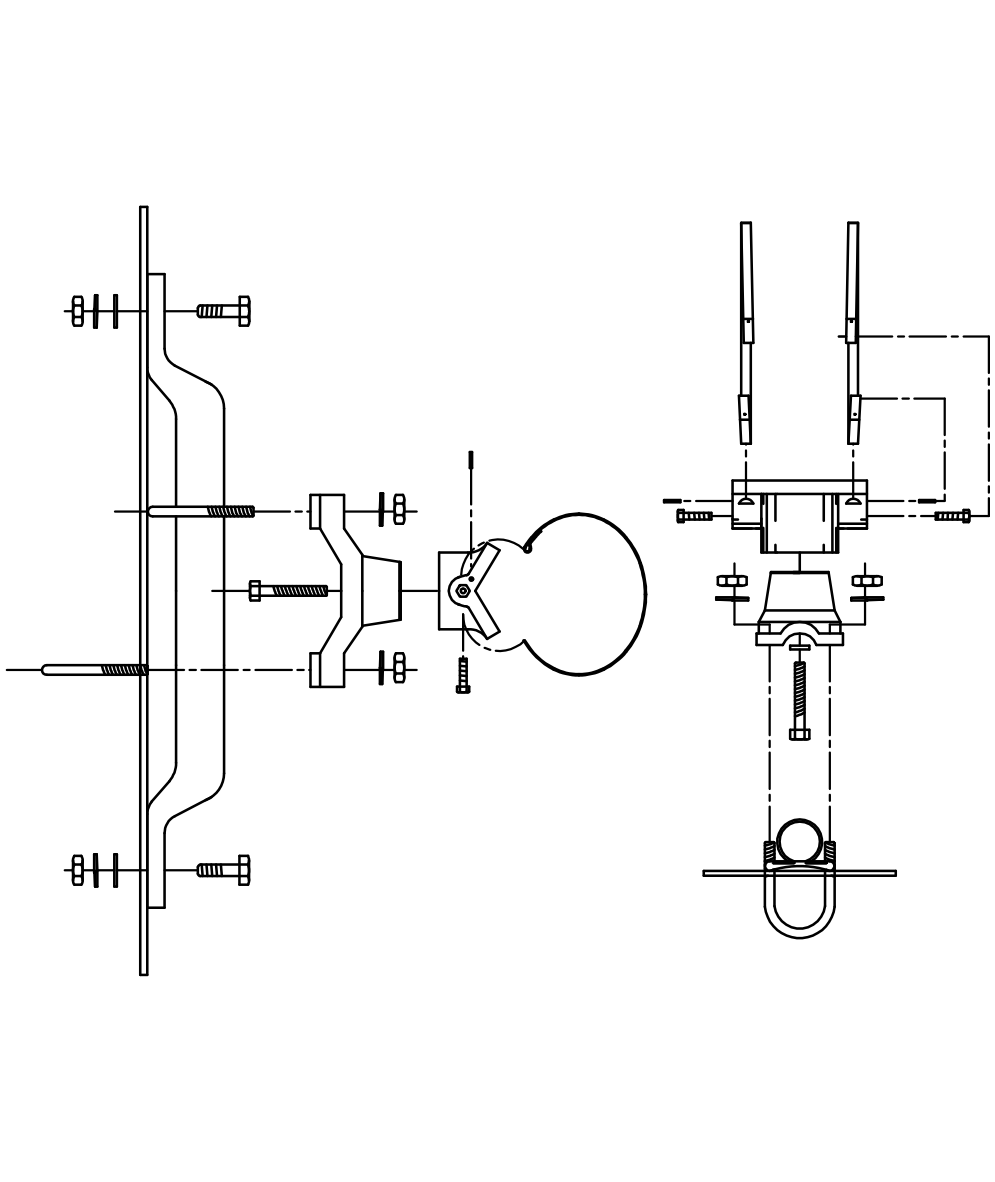

TYPE I SIGNAL MOUNTING BRACKET ASSEMBLY DETAIL

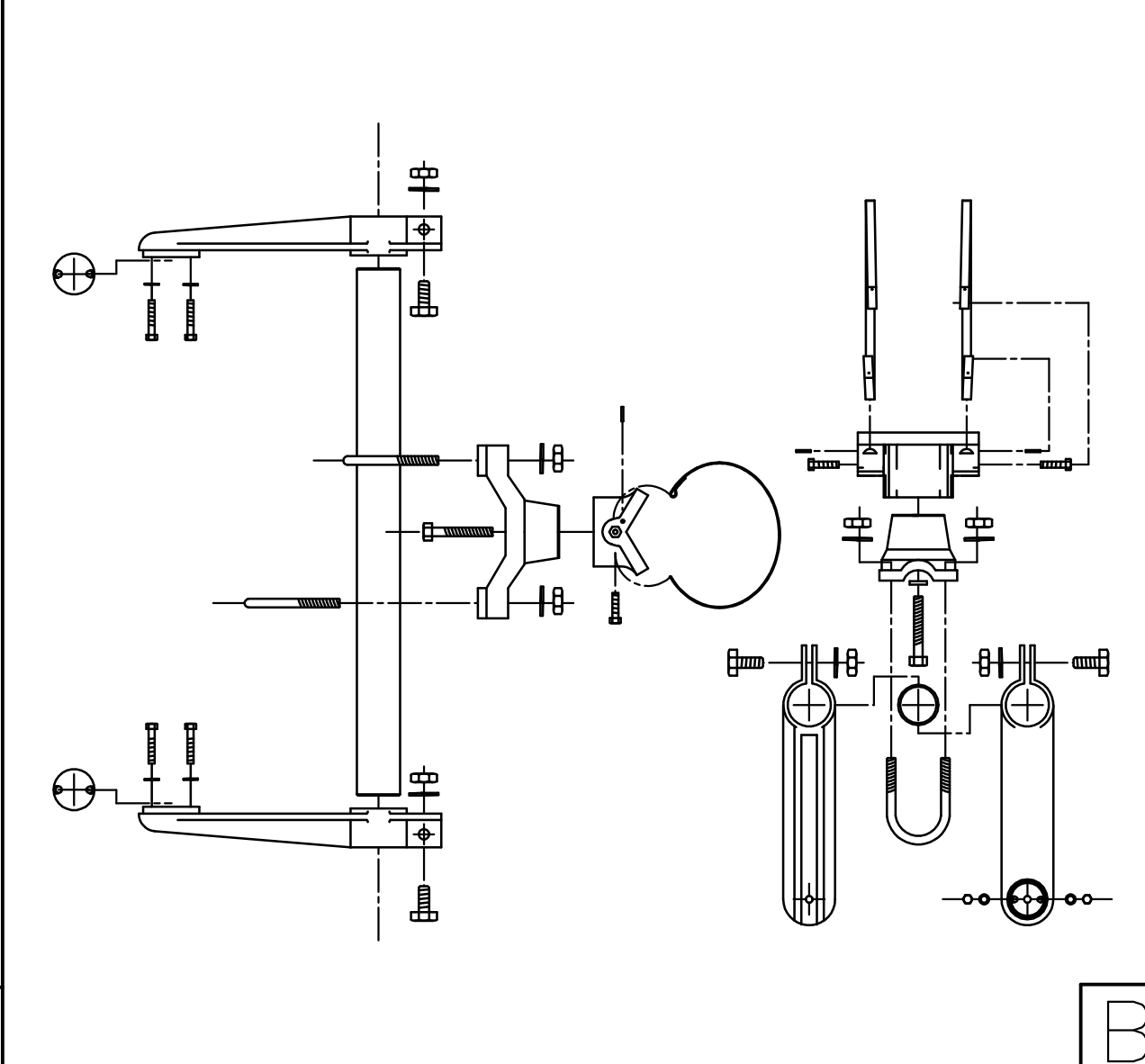

STANDARD SIGNING

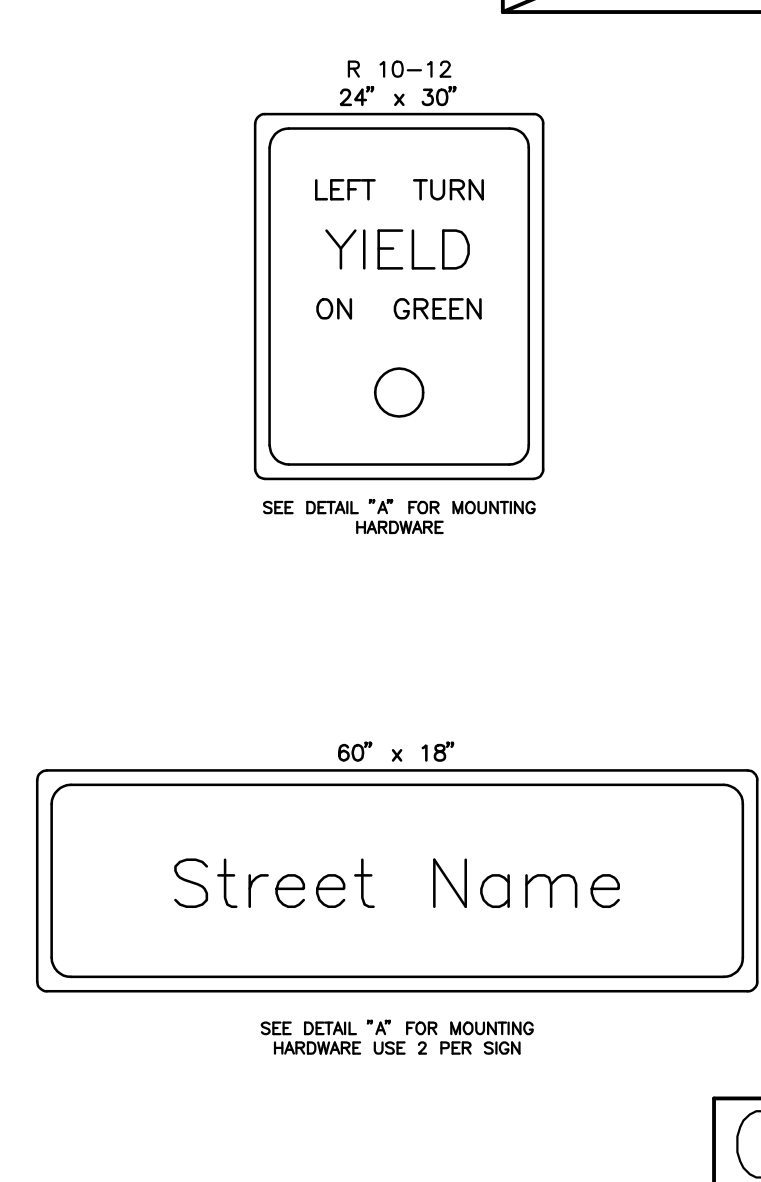

TYPE III SIDE-OF-POLE MOUNTING BRACKET ASSEMBLY

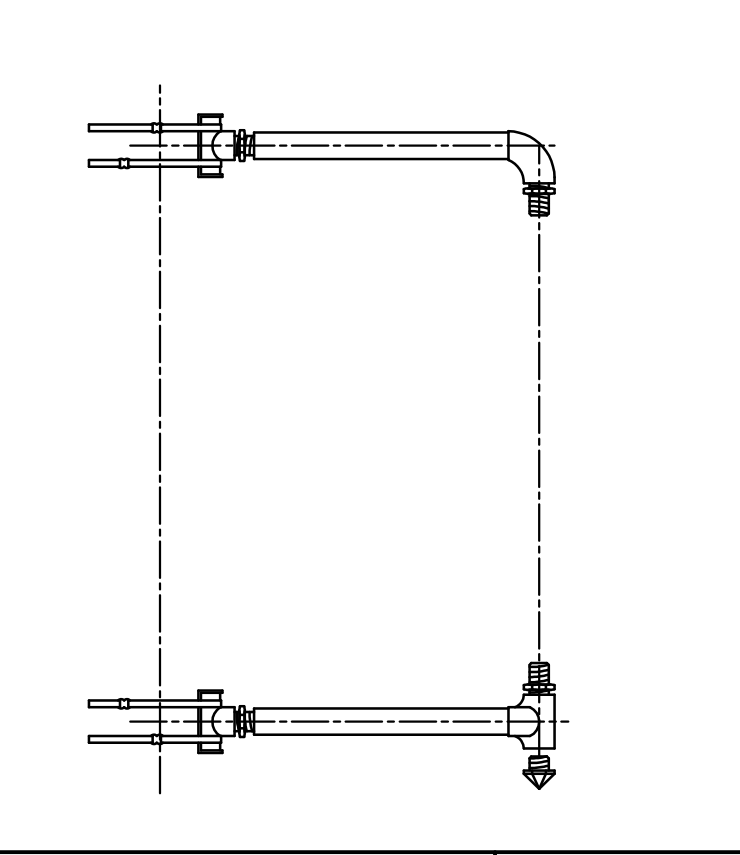

TYPE II SIGNAL MOUNTING BRACKET ASSEMBLY (SIDE-OF-POLE)

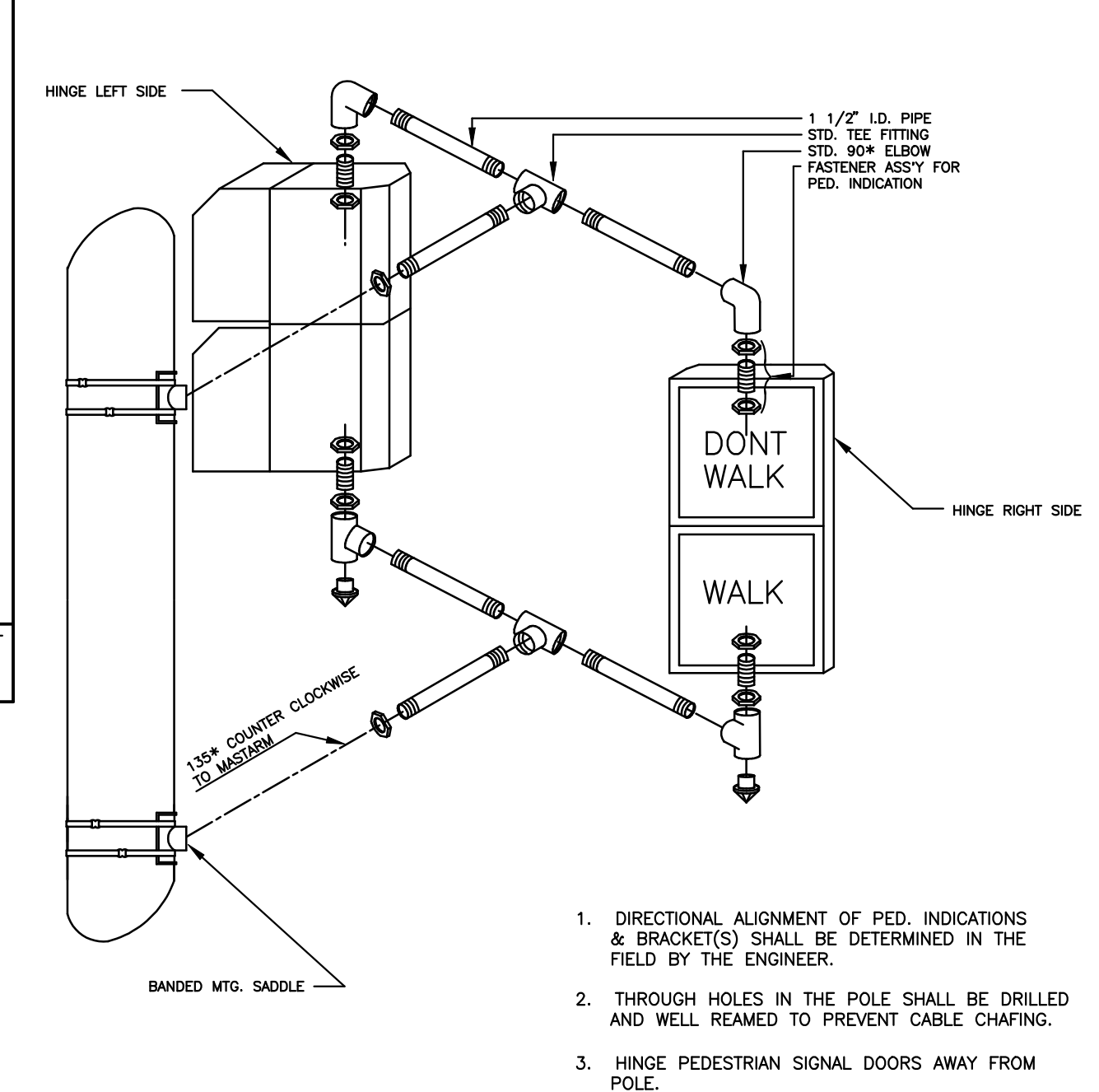

REBAR CAGE

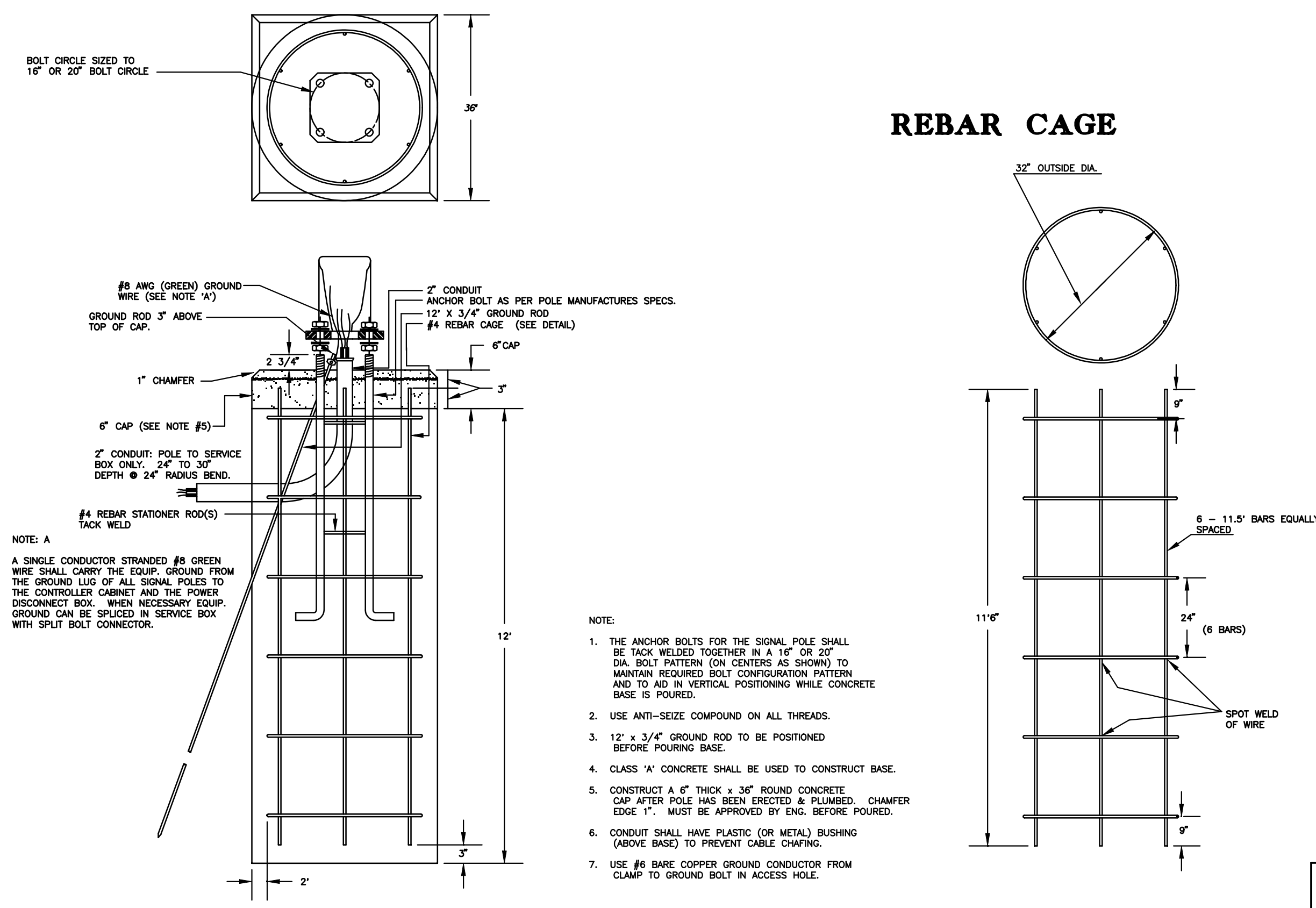

WASHINGTON STREET		
STEEL SIGNAL POLE ASSEMBLY DETAILS		
PROJECT NUMBER 472-84657		
DRAWN BY: T.M.	SCALE	REVISED BY:
DATE: MAY 97	NO SCALE	DATE:
CITY OF WICHITA DEPARTMENT OF PUBLIC WORKS		
DIVISION OF TRAFFIC ENGINEERING		
WM. G. MCKINLEY P.E.	TRAFFIC ENGINEER	SHEET R45 OF R73