

TRAFFIC CONTROL NOTES

COUNTY	STATE	PROJECT NUMBER	FISCAL YEAR	SHEET NO.	TOTAL SHEETS
SEDGWICK	KANSAS	472-84657	2008	R64	R73

- All traffic control devices and installation or use thereof shall comply with the Manual on Uniform Traffic Control Devices for Streets and Highways (Latest Edition), and all traffic control devices shall be NCHRP 350 compliant with respect to crashworthiness requirements.
- Whenever practical, all construction equipment, materials, and debris shall be stored no closer than thirty (30) feet from the traveled way. The contractor shall place appropriate signs or barricades, as directed by the Engineer, around any condition created by the contractor with thirty (30) feet of the traveled way that violates clear zone criteria stated herein. All devices needed to meet this requirement shall be considered subsidiary to the bid item "Traffic Control".
- Type "B" high intensity yellow flashing warning lights may be required on Type III barricades when deemed necessary by the Engineer.
- Barricades are to be set at locations shown on the traffic control plan sheets or as directed by the Engineer. Sufficient barricades shall be erected to adequately cover the roadway or lane width. The barricades may be mounted on approved skids anchored by wire or sandbags.
- The contractor is responsible for maintaining all devices in their proper position, cleaning or replacing any damaged or worn out device as directed by the Engineer without undue delay to ensure effective and safe traffic control.
- The contractor shall designate an employee, and an alternate, who will have the responsibility for signing and traffic control as noted on the traffic control plan and shall be available at all times to perform the above maintenance. The Engineer will be advised of the name and contact numbers/methods of the person and alternate given this responsibility. The Engineer shall conduct daily field inspections to see that the devices are in place and in satisfactory condition.
- Channelization devices: Devices as used herein shall include, but not be limited to Type I and Type II barricades.
 - The maximum spacing, in feet, between channelization devices in the taper should be approximately equal to the permanent speed limit, in miles per hour, prior to construction.
 - The spacing between devices in the work zone should be approximately 50 to 100 feet.
 - Devices placed along pavement edge or shoulder drop-offs of less than four (4) inches shall be placed a maximum of four hundred (400) feet apart as directed by the Engineer.
 - Devices placed along pavement edge or shoulder drop-offs of more than four (4) inches shall be placed a maximum of two hundred (200) feet apart as directed by the Engineer.
 - Type I or Type II barricades should be placed at approximately right angles to the center of the roadway.
 - All channelizing devices shall be fully reflectorized and, as directed by the Engineer, display the appropriate warning light on top of the device nearest the traveled way centerline.
- The lump sum price bid for the bid item "Traffic Control" shall be full compensation for providing, installing, moving, replacing, maintaining, removing and cleaning all traffic control devices as required or as directed by the Engineer. It shall also include the addition of any devices deemed necessary by the Engineer whether specifically mentioned or not.
- At all times, and during all weather conditions, access shall be maintained for local traffic to the satisfaction of the Engineer. This maintenance, including temporary surfacing material, if necessary, is subsidiary to the bid item "Traffic Control".

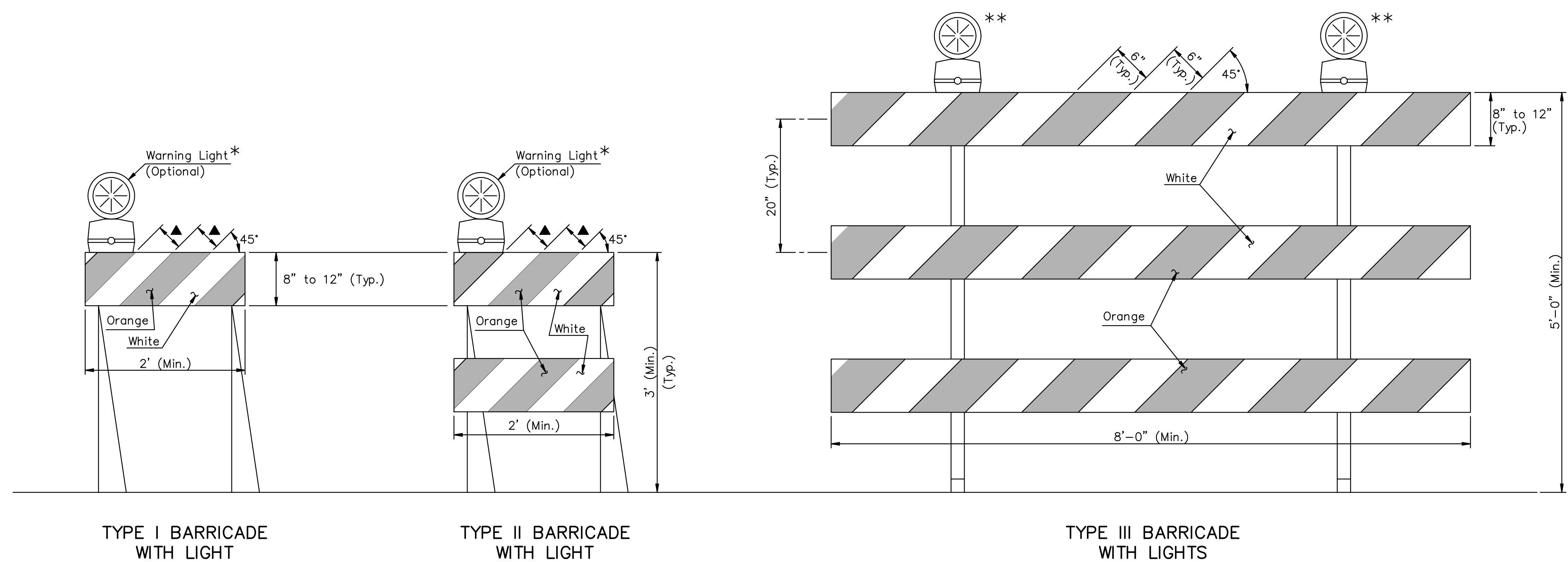

Type I and Type II barricades along shoulder edges or in drop-offs shall have a minimum of 36" from the top of the barricade to the top of the pavement.

The entire area of barricade rails are to be fully reflectorized with Type III or Type IV sheeting per FP-96.

▲ Rail stripe widths shall be 6", except that 4" wide stripes may be used if rail lengths are less than 36".

WARNING LIGHTS

Warning lights shall be in accordance with the current ITE purchase specifications for flashing and steady burn warning lights.

Type A low intensity flashing warning lights and Type C steady burn warning lights shall be maintained so as to be capable of being visible on a clear night from a distance of 3,000 feet. Type B high intensity flashing warning lights shall be maintained so as to be capable of being visible on a sunny day when viewed without the sun directly on or behind the device from a distance of 1,000 feet.

* Lights used on Channelizing Devices
 When used singly --- Type "A" Flashing
 When used in series - Type "C" Steady Burn
 The lens shall be a minimum of 7" in diameter.

Signs mounted on Type III barricades should not cover more than 50 percent of the top two rails or 33 percent of the total area of the three rails.

Barricade rails shall be plastic and the complete barricade shall be NCHRP 350 compliant. For rails less than 3 feet long, 4 inch wide stripes may be used.

Where barricades extend entirely across a roadway, and where both right and left turns are provided for, the chevron striping shall slope downward in both directions from the center of the road. When a detour is provided the stripes shall slope downward in the direction toward which traffic must turn.

Barricades intended for use on expressways, freeways, and other high speed roadways shall have a minimum of 270 square inches of reflective area facing traffic.

** A minimum of two Type "A" lights shall be used at each location where a Type III barricade or barricades are used. A light shall be mounted on the outside corner at the end barricades when more than one is used. The lens shall be a minimum of 7" in diameter.

All barricades shall be faced with reflective sheeting on the front and back faces.

Rev.Date	Description	By	/Chk
TRAFFIC CONTROL DETAILS BARRICADES			
TC 2-0			
PREPARED BY SEDGWICK COUNTY PUBLIC WORKS HIGHWAY DEPARTMENT			
DAVID C. SPEARS, P.E.		DIRECTOR/COUNTY ENGINEER	
REVISED	SCALE	DESIGNED	DRAWN
	NONE	M.R.B.	D.R.S.
	DATE	2/2005	4/2005
			CHECKED
			M.R.B.
			DATE
			4/2005
SHEET NO. R64			
DWG: TC2-0.dwg			