

STATE	PROJECT NO.	YEAR	SHEET NO.	TOTAL SHEETS
KANSAS	472-84744	2009	R29	R78

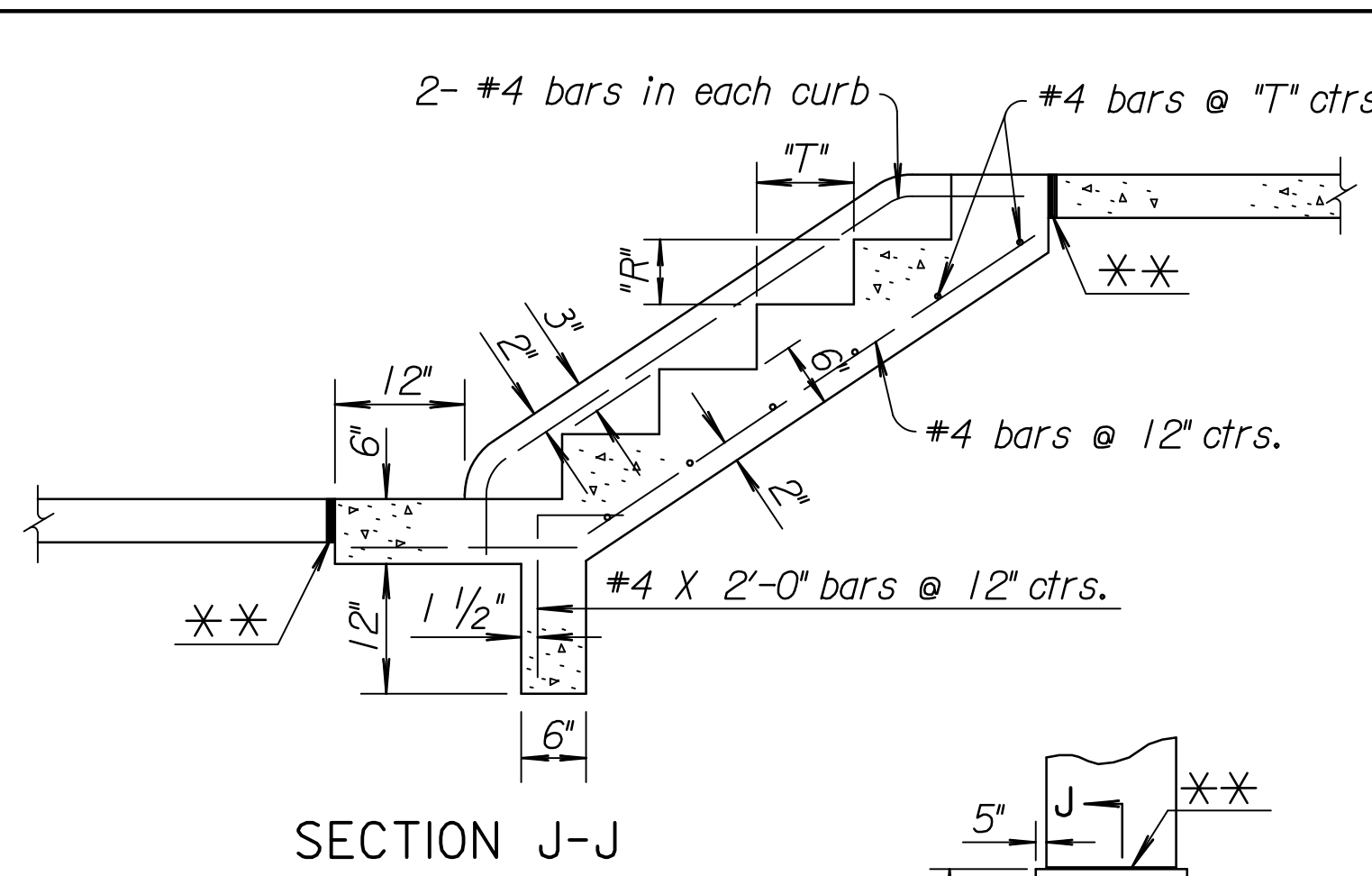
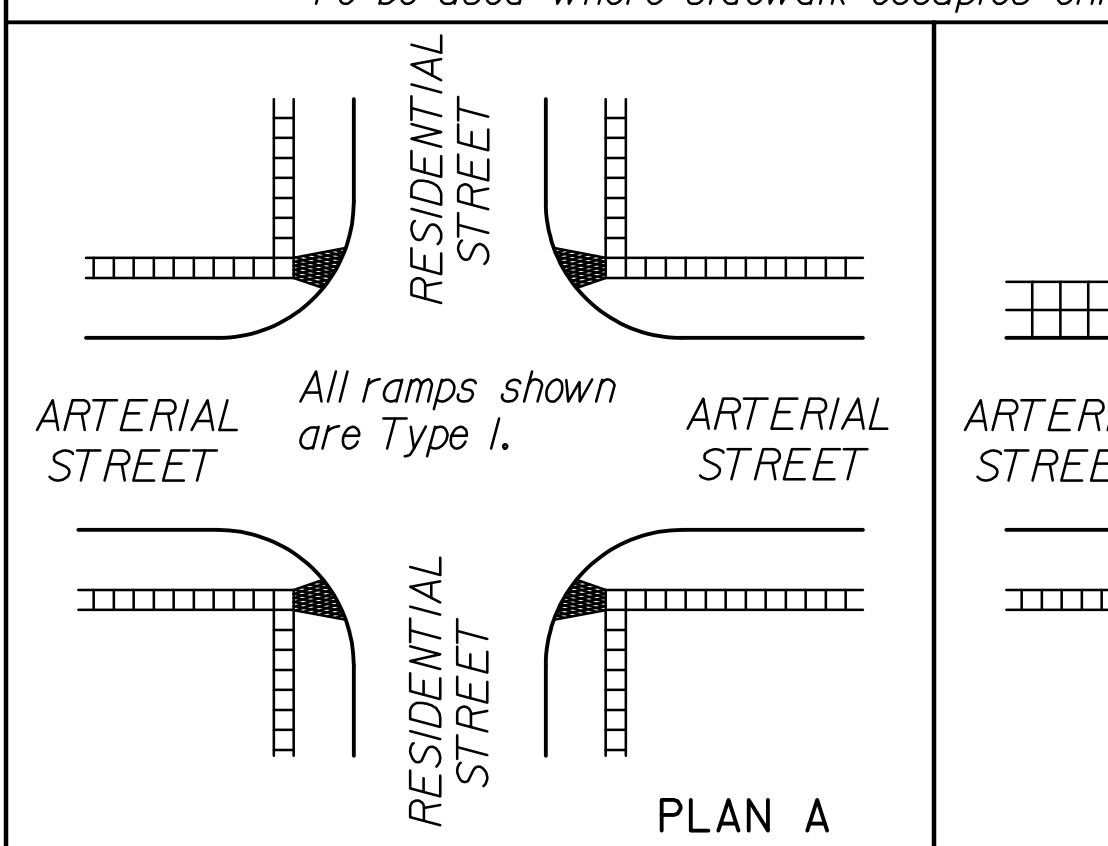
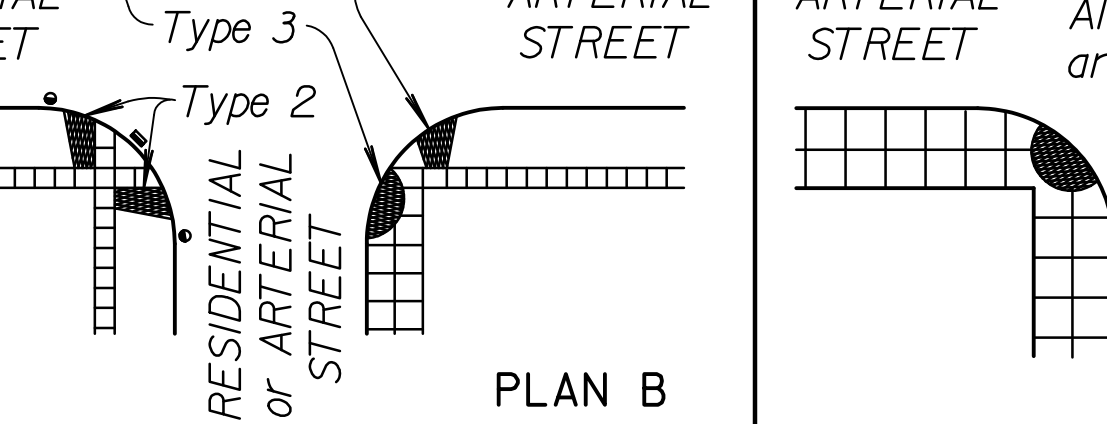
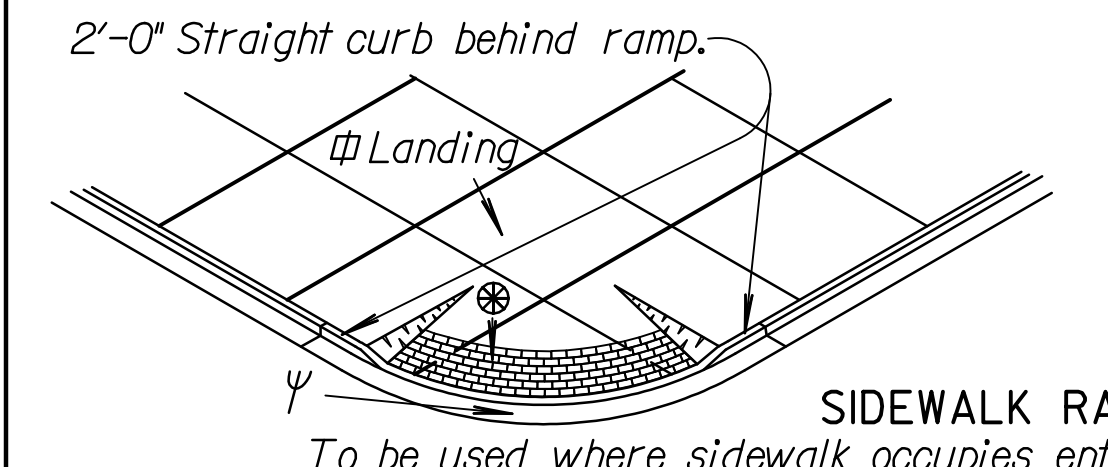
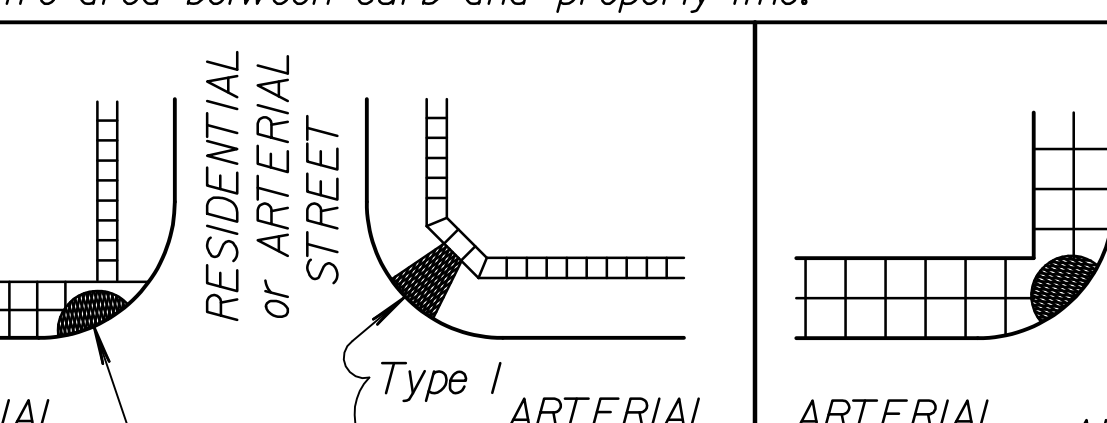
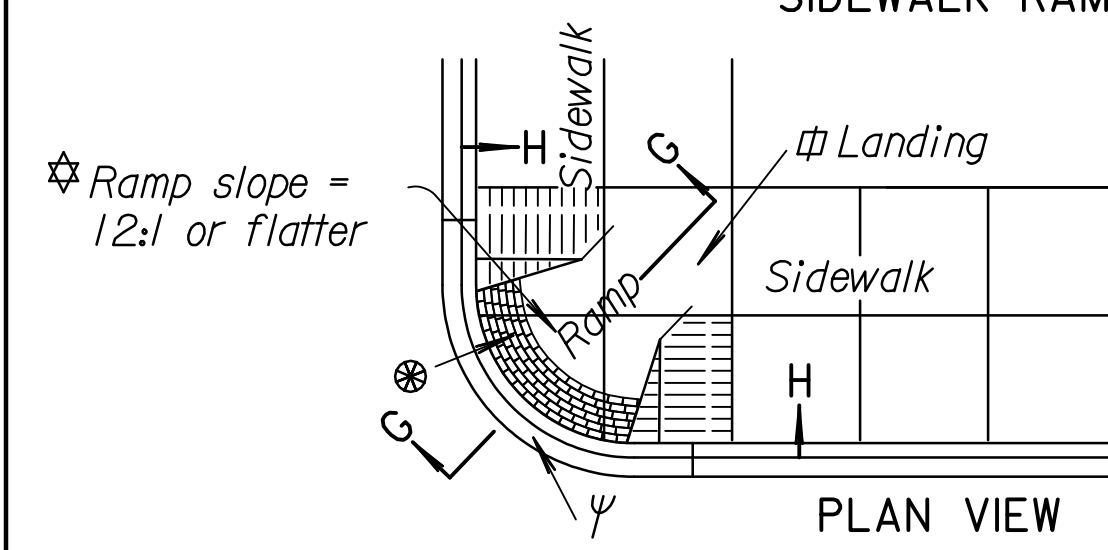
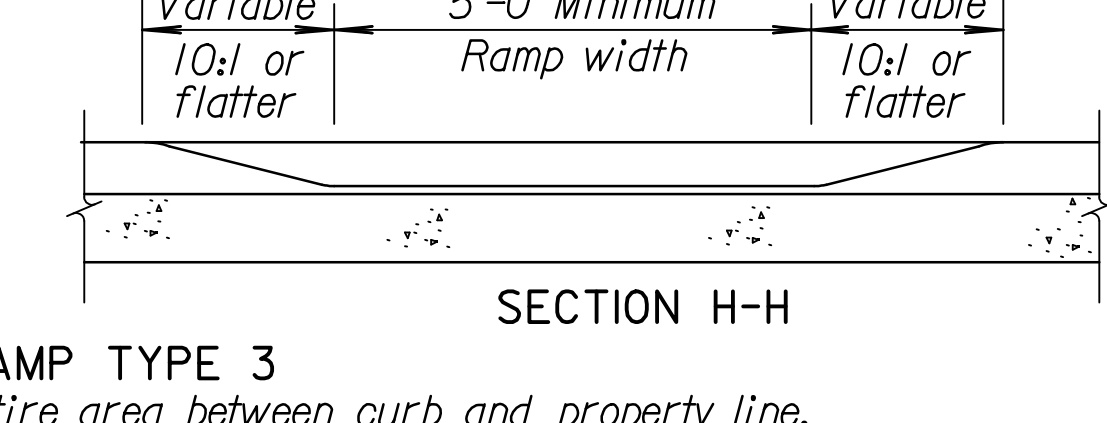
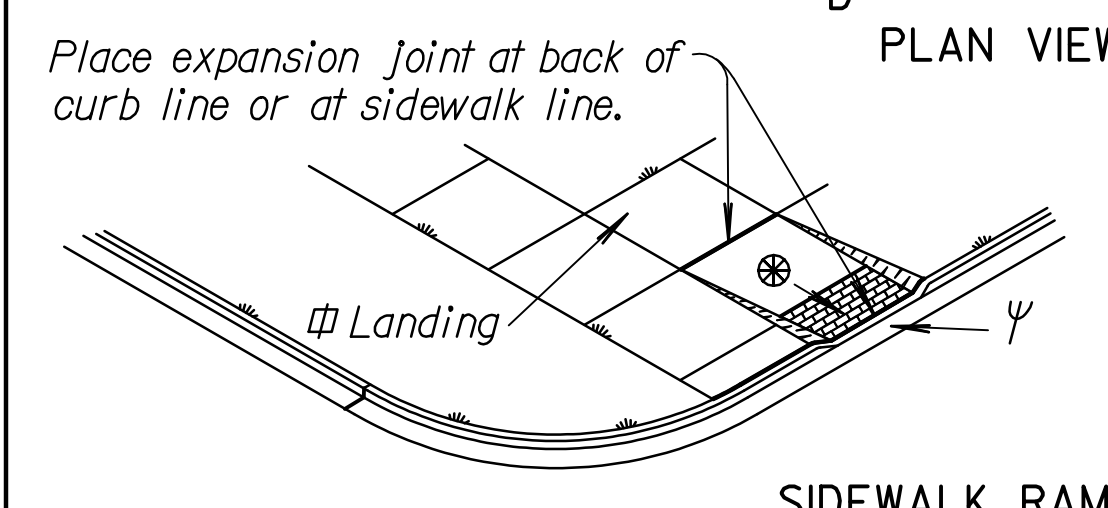
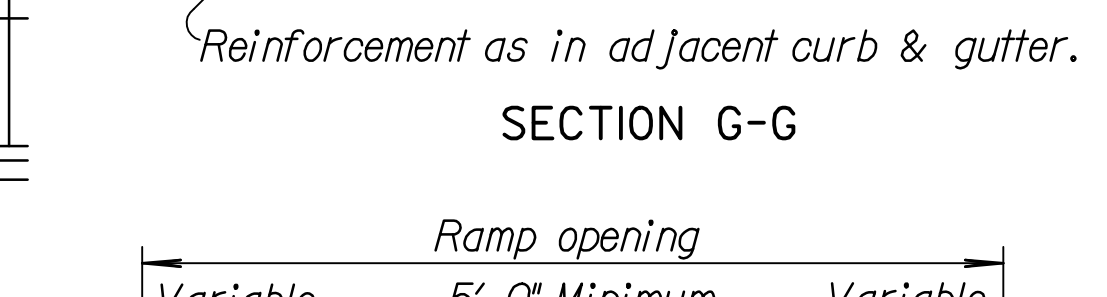
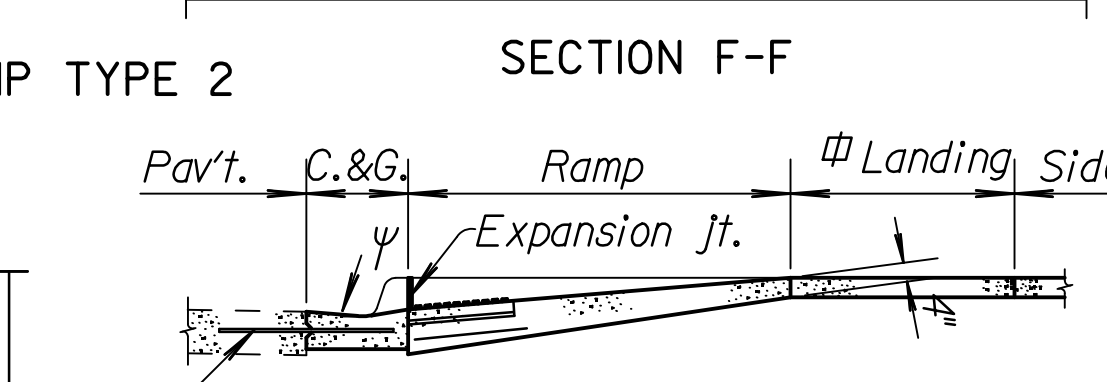
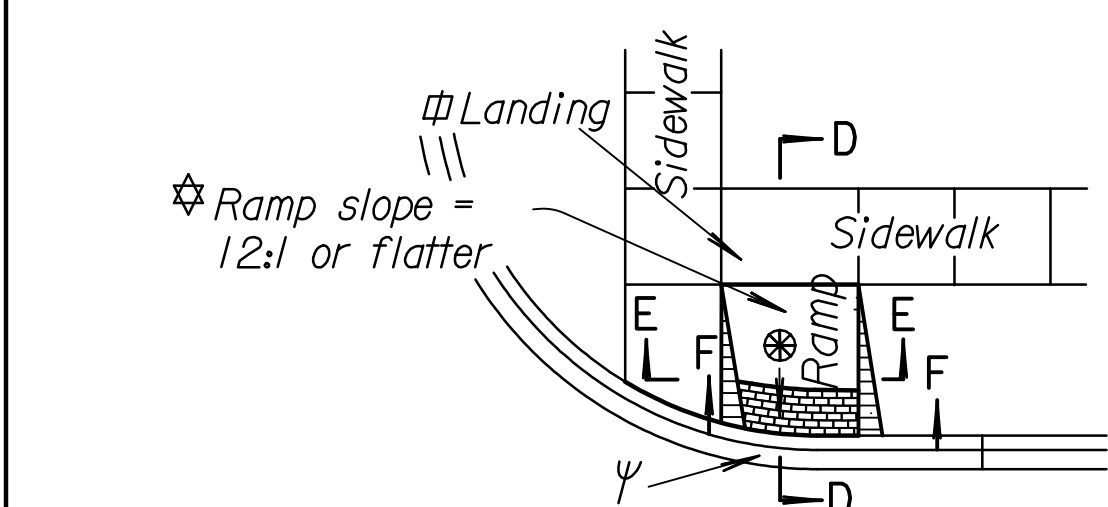
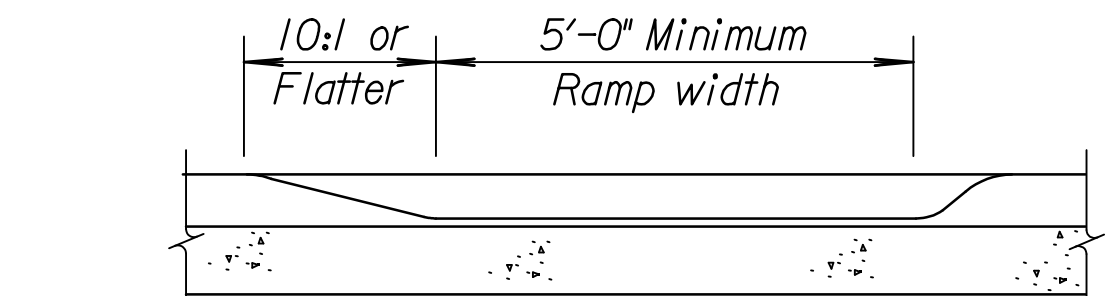
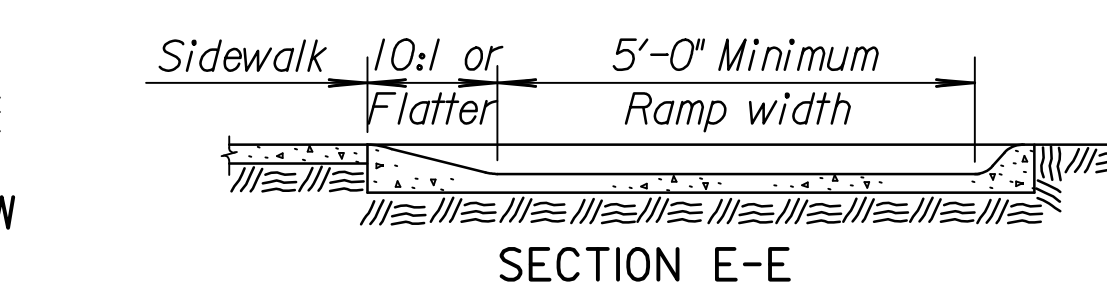
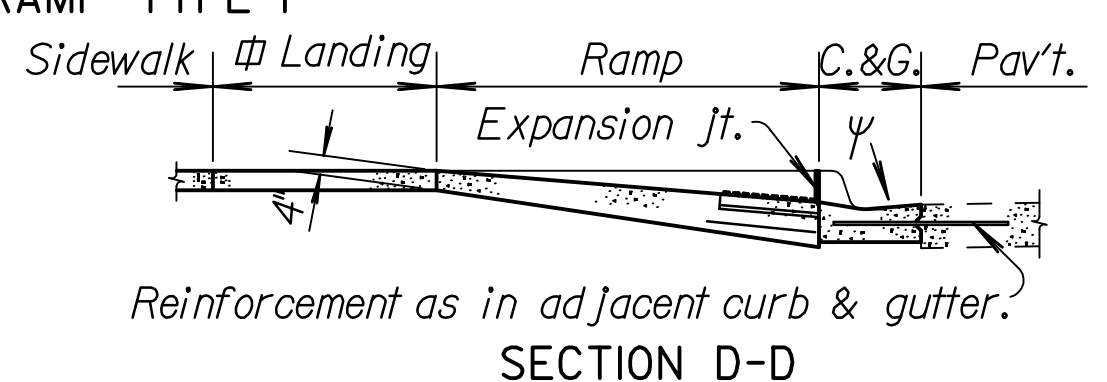
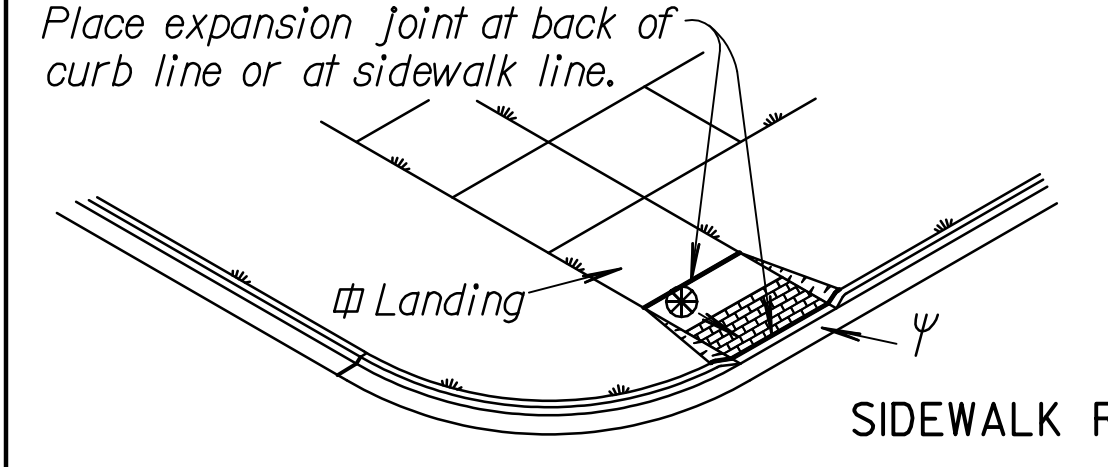
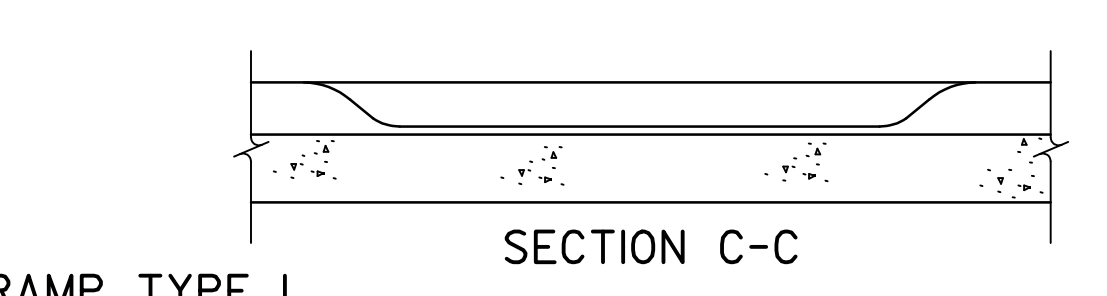
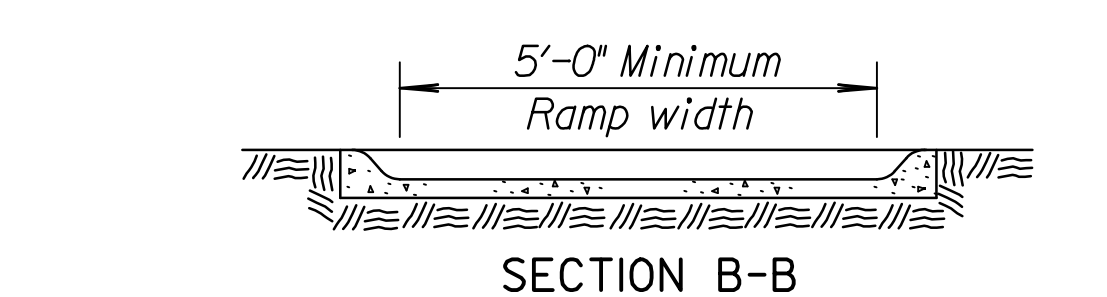
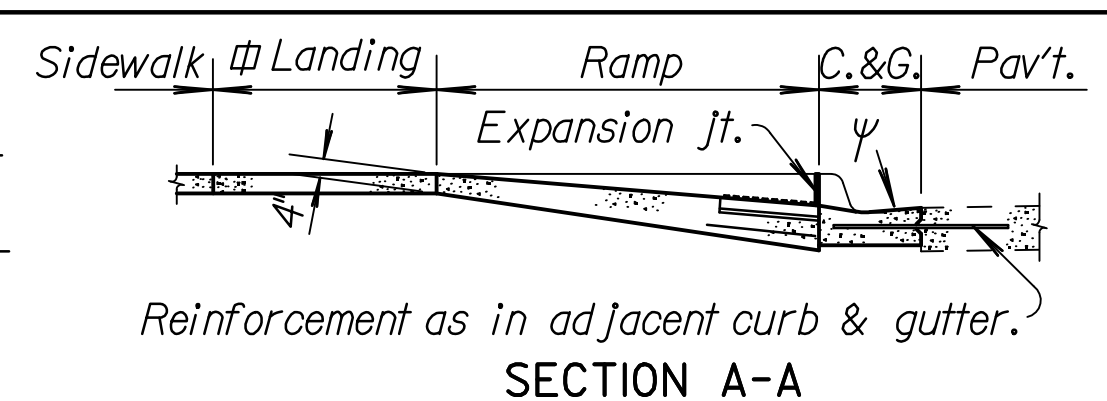
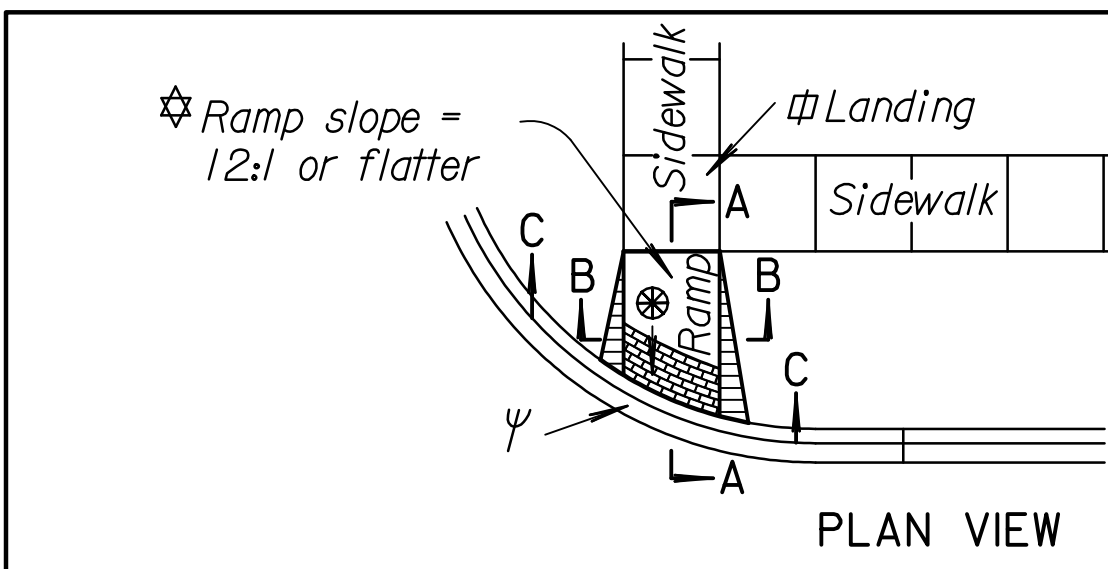

Step formula:
 "R" x "T" = not less than 70 nor more than 75.
 The maximum "R" = 6 3/4"
 The minimum "T" = 11"

Construction joints or planes of weakness spaced @ 6'-0" ctrs. or less.

⊛ Ramp slopes in new construction shall be 12:1 or flatter. Desirable ramp slopes on existing sites shall be 12:1 or flatter. Where space limitations prohibit construction of 12:1 slopes at existing sites slopes shall be as follows:
 8:1 or flatter for a maximum rise of 3 inches
 10:1 or flatter for a maximum rise of 6 inches

⊕ Landing slopes shall be 48:1 or flatter. Landings shall be the same width as the ramp and min. 5'-0" in length.

ψ The counter slope shall be 20:1 or flatter at the base of sidewalk ramps. Refer to standard drawing RD725A for additional curb and gutter details.

⊛ Detectable warning installation is typical and required on Sidewalk Ramps Type 1, Type 2, Type 3, median ramp crossings and other locations as shown in the plans. Refer to standard drawing RD725A for additional details.

Note: Reinforcing bars shown are to be used only when more than four steps are necessary.
 Where field conditions permit, the steps should not be constructed too steep.

⊕ Expansion Joint (3/4" Redwood board) placed at either back of curb line or at sidewalk line.
 ** Expansion Joint (3/4" redwood board) located as shown.

◆ Variable width (5'-0" min.). Entrance walk to be same width as approach walk. Sidewalk width of 4'-0" may be used where existing conditions prohibit use of 5'-0".

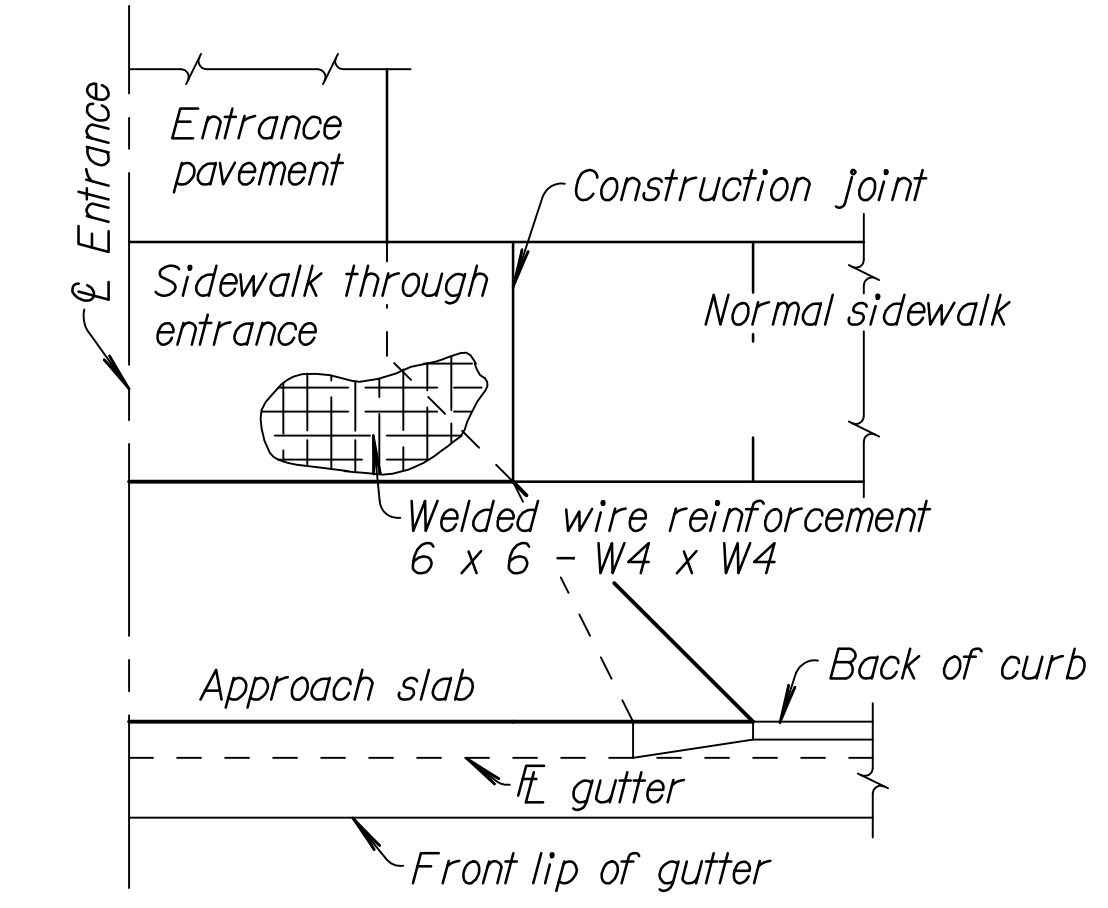
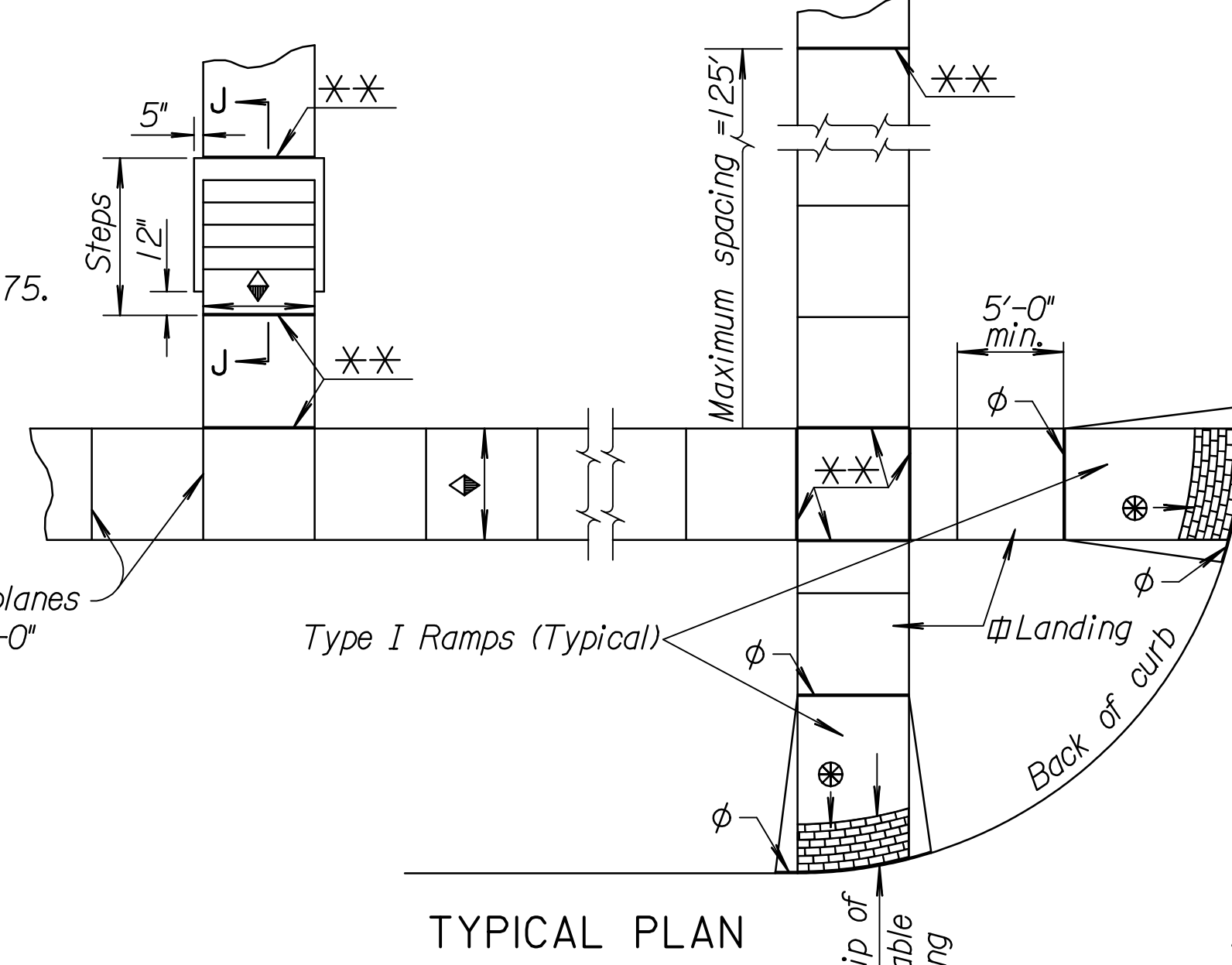

REINFORCEMENT DIAGRAM SIDEWALK THROUGH ENTRANCE
 See Std. Drawing RD726 for details of Alley and Entrance Pavement.

GENERAL NOTES

The details depicted here may not be appropriate for all locations. Designs shall meet this criteria on all new construction projects unless impracticable by site restrictions. For an existing sidewalk facility where the sidewalk will be replaced, this sidewalk will be replaced according to this drawing to the maximum extent feasible.

Ramps shall be provided at all corners of street intersections where there is existing or proposed sidewalk and curb. Ramps shall also be provided at walk locations in mid-block in the vicinities of hospitals, medical centers and athletic stadiums.

Details shown on this sheet apply to all construction or reconstruction of streets, curbs or sidewalks. Use of sidewalk ramp Type 2 shall be restricted to locations where it is not feasible to use Types 1 or 3.

Curb cut ramps are to be located as shown on the plans or as directed by the Engineer.

If possible, drainage structures should not be placed in line with ramps. Except where existing drainage structures are being utilized in the new construction, location of the ramp should take precedence over location of drainage structure.

Sidewalks shall be ramped where the driveway curb is extended across the walk.

Care shall be taken to assure a uniform grade on the ramp, free of sags and short grade changes.

Expansion joints shall be placed in sidewalks as follows: In long runs, expansion joints shall be 3/4" redwood boards flush with the surface, at a maximum spacing of 125'. This same joint should be used at sidewalk junctions as shown in Typical Plan.

Where the end of the sidewalk abuts a curb, a 3/4" redwood board flush with the surface shall be used.

Where the sidewalk is parallel and adjacent to a rigid structure, a 1/2" pre-molded joint filler (Non-extruding, Type B) shall be used.

Sidewalk shall slope toward the street at a 50:1 or flatter, and where necessary, may be depressed or sloped to fit alleys and entrances as shown on the plans or as directed by the Engineer.

Where clear width of sidewalk between top of ramp and building or other obstruction is less than 48 inches, the slope of the flared sides shall be 12:1 or flatter.

Where sidewalk is shown to be constructed back of an entrance it shall be 6" thick with welded wire mesh reinforcement of the same gauge and spacing of wires as in entrance pavement, as shown in the Reinforcement Diagram. Bid item will be "Sidewalk Construction (6") either with or without air entrainment.

Where the plans do not require air entrainment for sidewalk and sidewalk ramps, at the Contractor's option, Concrete Grade 3.0 (AE) may be used throughout. Payment will be made as square yards of Sidewalk Construction.

At the Contractor's option Concrete Grade 3.0 (AE) may be used throughout for construction of steps, but payment will be made as Concrete Grade 3.0.

Surface texture of the ramp shall be that obtained by a wooden float or brushed finish to the slope of the ramp.

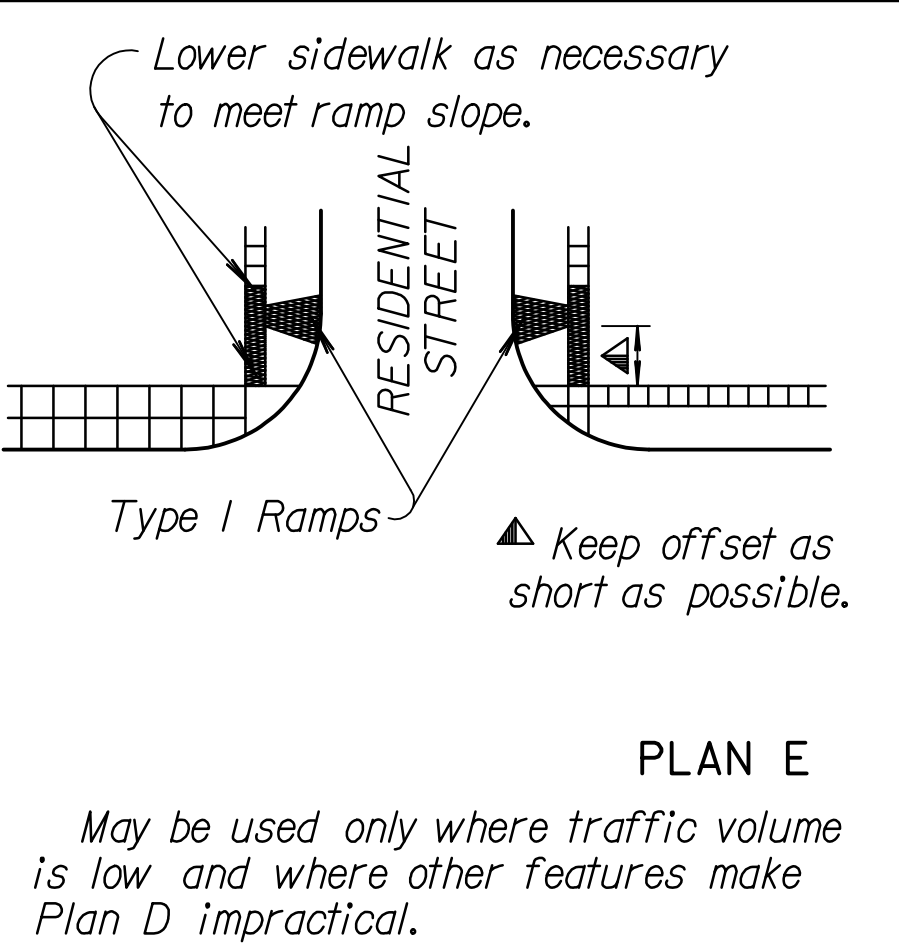
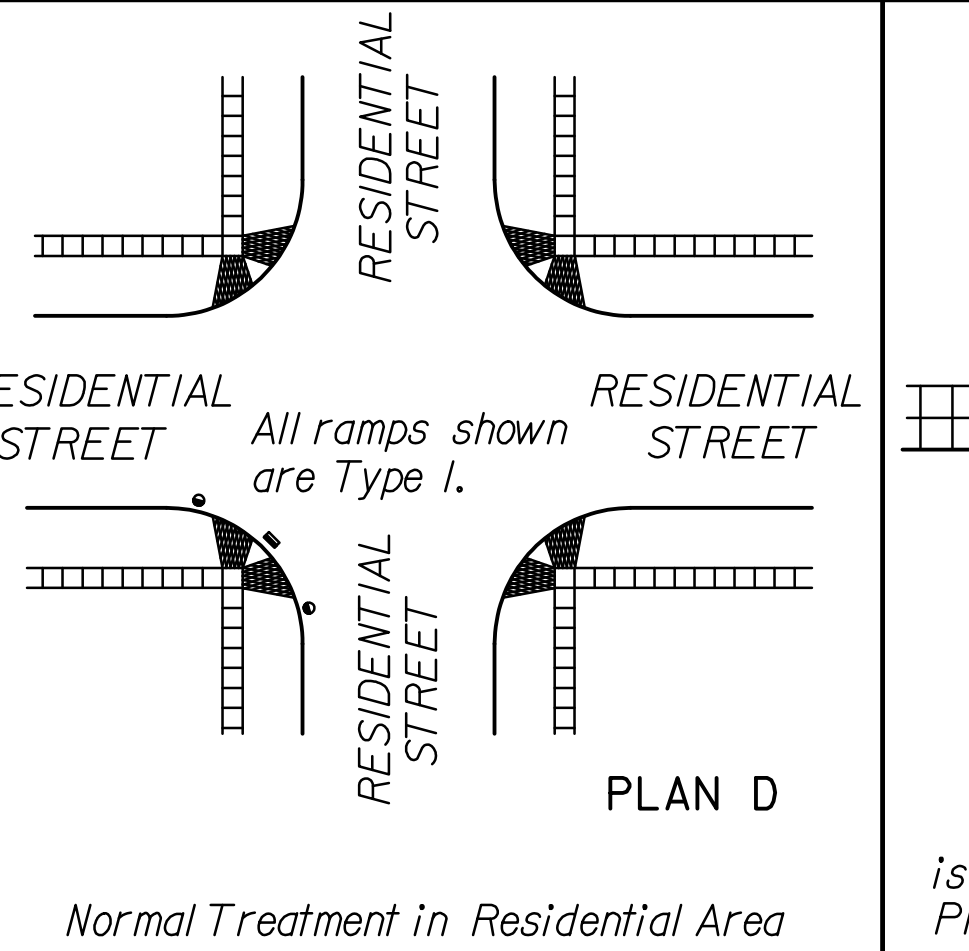
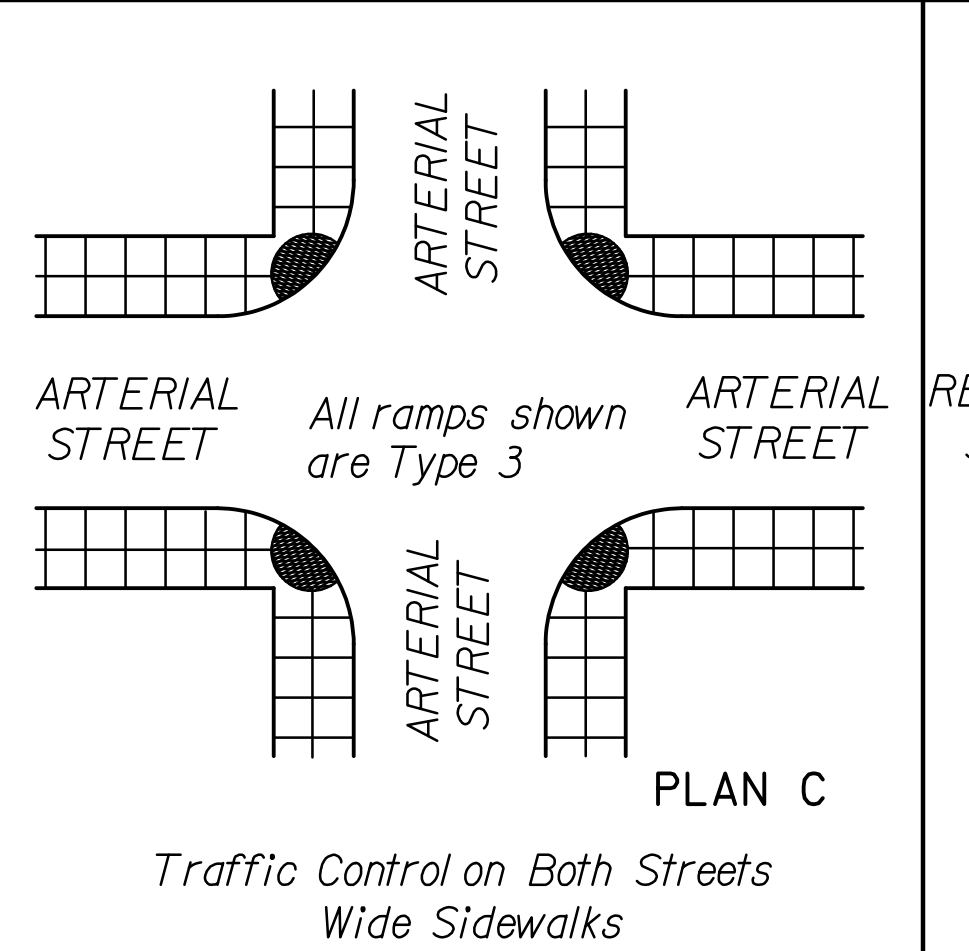
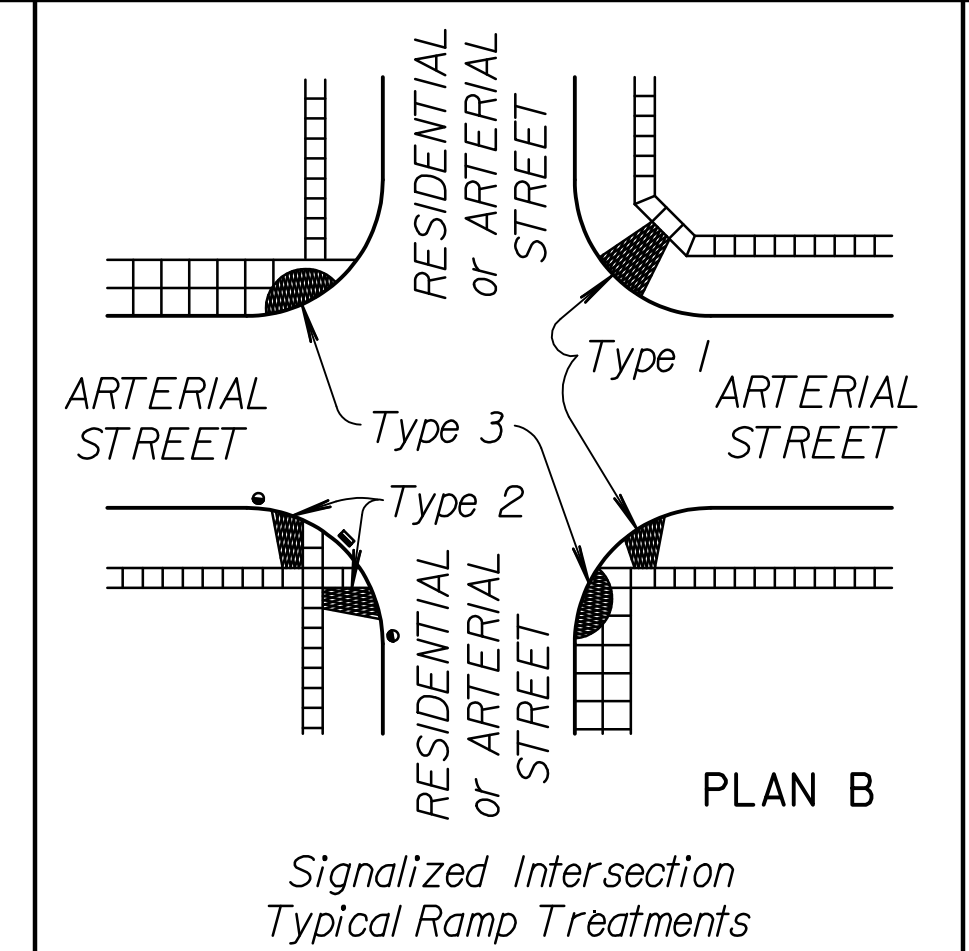
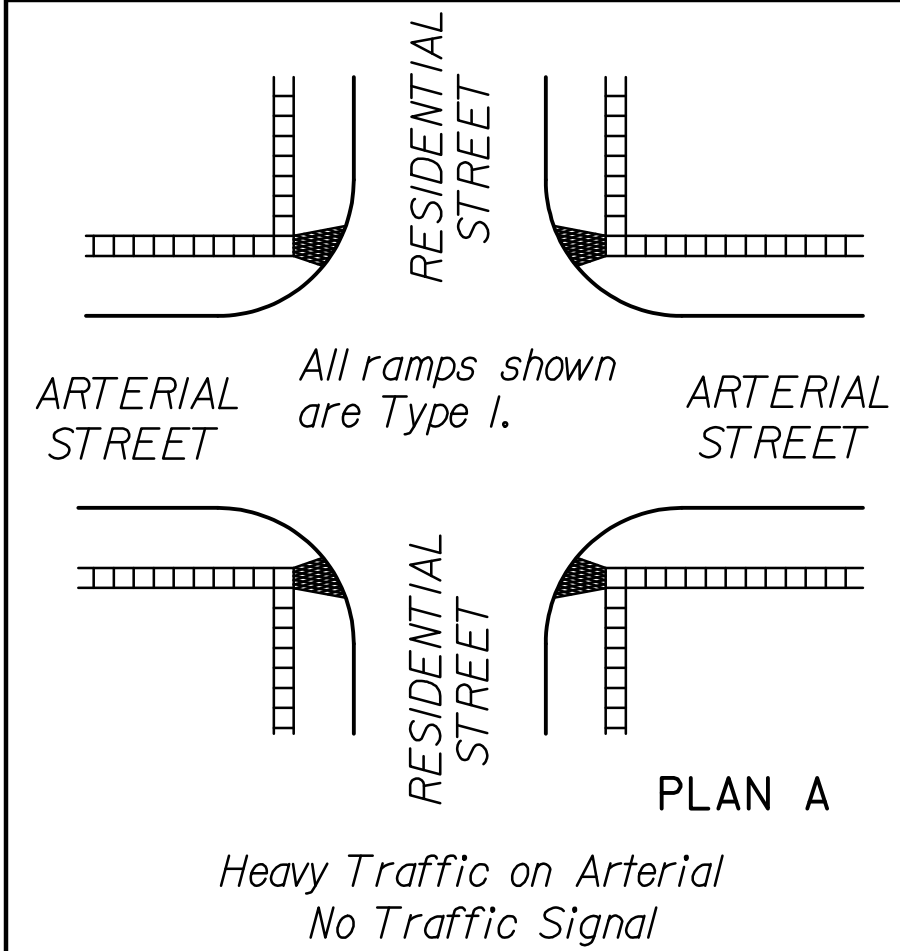

LEGEND

Sidewalk Ramp Type 1	
Sidewalk Ramp Type 2	
Sidewalk Ramp Type 3	
Preferred location of drainage inlet (Typical)	
Alternate location of drainage inlet (Typical)	
Sidewalk	

7	1-28-05	Changed Class to Grade concrete	S.W.K.	J.O.B.
6	8-20-03	Revised notes and details	S.W.K.	J.O.B.
5	6-2-03	Added Detectable Warning details	S.W.K.	J.O.B.
4	6-27-97	Revised ramp thickness	R.J.S.	J.O.B.
NO.	DATE	REVISIONS	BY	APP'D

KANSAS DEPARTMENT OF TRANSPORTATION

SIDEWALK & STEPS

RD725

FHWA APPROVAL	5-25-05	APP'D. James O. Brewer
DESIGNED	DETAILED	QUANTITIES
DESIGN CK.	DETAIL CK.	QUAN. CK.

TRACED Bowser
TRACE CK. Seltz

Drawn By: unittied
 Plotted: 3/19/2009
 File: I:\2008\08456\Standards\08456-rd725.dgn