

- ⊗ Power Supply
- # Ground Wire #8 AWG
- * Communication Cable

WIRING DIAGRAM

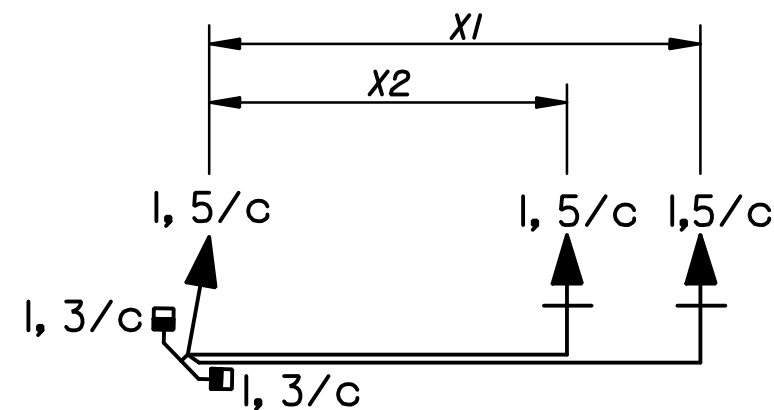

TYPICAL POLE WIRING

Note: Each Pushbutton to be wired with 1, 2/c to pole base connection.

All splices to be in pole base, no splices permitted within service box.

NUMBER	TYPE	SIZE	QUANTITY
4	A	12'	3
2A	K	16'x18"	2
TOTAL			5

SERVICE BOX SUMMARY

STATION	DIST.-SIDE
607+37	29' Lt.
607+37	29' Rt.

ITEM	UNIT	QUANTITY
POLE MOUNTED CONTROLLER & CABINET	EACH	1
TRAFFIC SIGNAL HEAD W/MOUNTING HARDWARE	EACH	5
TRAFFIC SIGNAL POLE STEEL (20')	EACH	1
TRAFFIC SIGNAL PEDESTAL ALUM. (15')	EACH	1
TRAFFIC SIGNAL PEDESTAL (JOINT USE) ALUM. (35')	EACH	-
CONCRETE CONTROLLER PAD	EACH	-
CONCRETE FOOTING - PEDESTAL	EACH	1
CONCRETE FOOTING - POLE	EACH	1
CONDUIT ELBOW 90°2"	EACH	AS REQ'D
CONDUIT ELBOW 90°3"	EACH	AS REQ'D
BACK PLATE 5' 3 SECTION	EACH	2
BACK PLATE 5' 5 SECTION	EACH	-
TERMINAL BLOCK	EACH	-
SERVICE BOX	EACH	2
JUNCTION BOX (PRE-FAB)	EACH	-
GROUND ROD & CLAMP	EACH	3
PEDESTRIAN INDICATIONS LED (16'x18" COMBINATION) (COUNTDOWN)	EACH	2
LED TRAFFIC SIGNAL LENS (12")	EACH	9
ENTRANCE HEAD	EACH	-
CIRCUIT BREAKER & BOX 50 AMP.	EACH	1
SURGE ARRESTOR - A.C.SERVICE	EACH	1
SURGE ARRESTOR - DETECTOR	EACH	-
PEDESTRIAN PUSHBUTTON W/SIGN	EACH	2
6 PR. COMMUNICATION CABLE	LIN.FT.	280
DETECTOR LOOP WIRE NO.14 AWG 1/c	LIN.FT.	-
LEAD-IN WIRE NO.6 AWG 1/c	LIN.FT.	AS REQ'D
MULTI-CONDUCTOR CABLE NO.14 AWG 7/c	LIN.FT.	200
MULTI-CONDUCTOR CABLE NO.14 AWG 5/c	LIN.FT.	125
MULTI-CONDUCTOR CABLE NO.14 AWG 3/c	LIN.FT.	35
SHEILDED DETECTOR LEAD-IN NO.14 AWG 2/c	LIN.FT.	-
CONDUIT 1"(RGC)	LIN.FT.	AS REQ'D
CONDUIT 1 1/2"(RGC)	LIN.FT.	-
CONDUIT 2"(PVC)	LIN.FT.	-
CONDUIT 2"(RGC)	LIN.FT.	215
CONDUIT 3"(RGC)	LIN.FT.	480
#8 AWG GROUND (GREEN)	LIN.FT.	85
STREET NAME SIGN	EACH	-
NO LEFT TURN (R3-2) SIGN	EACH	-
RIGHT TURN ONLY (R3-5R) SIGN	EACH	-

POLE NO.	TYPE ①	ARM LENGTH	NO. OF SIGNALS ON ARM	BRACKET TYPE	X1	X2	X3	X4	NO. OF SIGNALS ON POLE	BRACKET TYPE	NO. OF PUSH BUTTONS ON POLE	REMARKS
1	A	-	-	-	-	-	-	-	1	III	1	
2	B	36	2	I	35	24	-	-	2	II/III	1	

- ① A-15' Pedestal (Alum.)
- B-20' Steel with Mast Arm(s)
- C-35' Steel (Joint Use) with Mast Arm(s)
- D-40' Steel with Mast Arm

ITEM	UNIT	QUANTITY
TRAFFIC SIGNAL INSTALLATION	LUMP SUM	LUMP SUM
Emporia Crosswalk	1	1

POLE AND EQUIPMENT FINISH:

Surface preparation

The exterior steel surface shall be blasted clean in accordance with the requirements outlined in the Steel Structures Painting Council Surface Preparation Specification No. 6, (SSPCSP60) utilizing a dry abrasive, closed cycle, recirculating system with centrifugal wheels and abrasive. The abrasive used shall be steel shot conforming to the Society of Automotive Engineers (SAE) Recommended Practice No. J827 with particle size meeting SAE Shot No. S280.

Zinc Coating

The pole assembly shall be hot-dip galvanized to the requirements of either ASTM A123 (Fabricated items) or ASTM A153 (Hardware items) by immersion in a molten bath of prime western grade zinc maintained between 810°F and 850°F. Maximum aluminum content of the bath shall not exceed 0.01%.

Top Coat

All visually exposed exterior surfaces shall be coated with a urethane or triglycidyl isocyanurate (TGIC) polyester powder to a minimum dry film thickness (DFT) of 0.05mm (2.0 mils). Prior to application of the topcoat, the surface shall be mechanically etched and pre-heated to 450°F for a minimum of one hour. The coating shall be electrostatically applied and cured at a minimum temperature of 400°F and the color shall be black.

-QUANTITIES FOR INFORMATION ONLY-

NOTE: The traffic signal system shall be complete and the contractor shall furnish and install all equipment and materials necessary for the satisfactory operation of electrical apparatus and for the complete operation of the traffic signal system whether specifically mentioned or not.

No.	Revision	By	Date
EMPORIA STREET			
WIRING AND QUANTITIES EMPORIA CROSSWALK			
JAMES L. ARMOUR, P.E. - CITY ENGINEER CITY OF WICHITA PROJECT NO. 472-84744			
Professional Engineering Consultants, P.A. 303 S. TOPEKA • WICHITA, KANSAS 67202 316-262-2691 • FAX 316-262-3003			
Designed by	DRM	Job No.	08456
Drawn by	DRP	Date	Feb., 2009
			Sht. R42 of R78