

**PLAN**

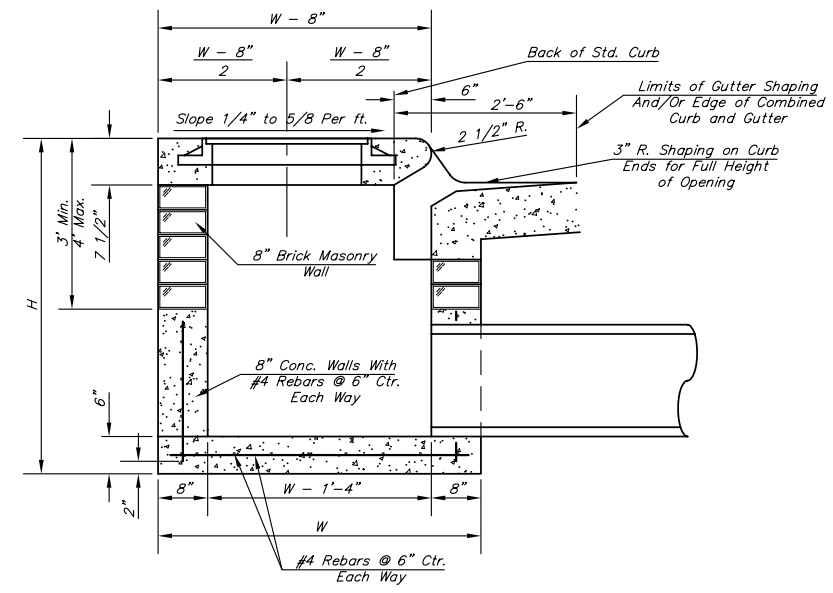

**SECTION A-A**

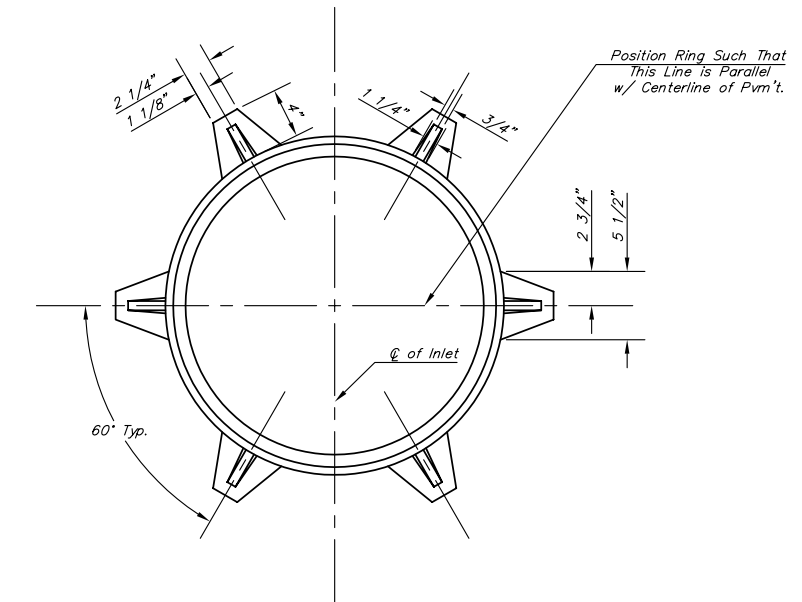

**MANHOLE RING AND COVER**

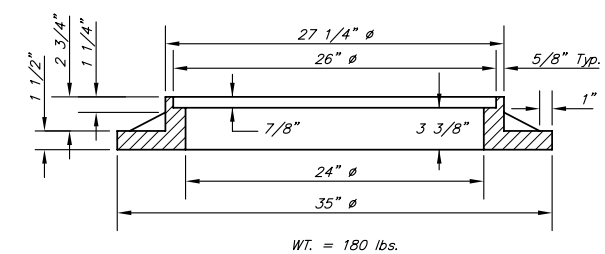

**BENDING DIAGRAM**

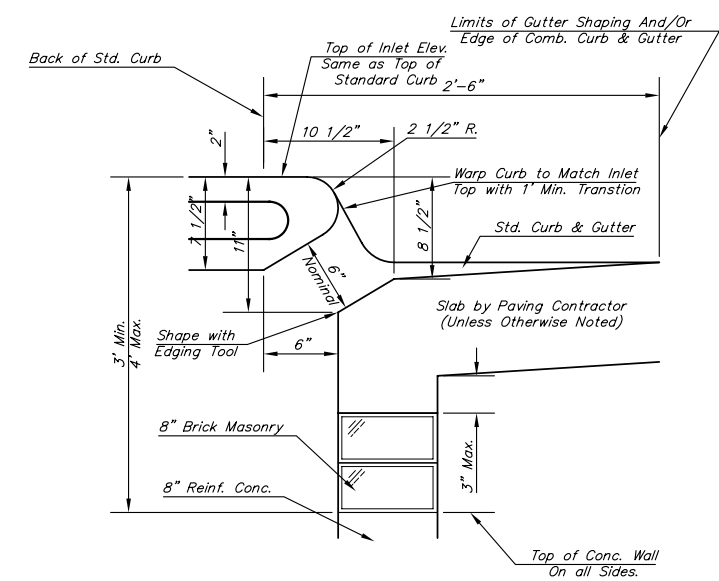

**SECTION B-B**

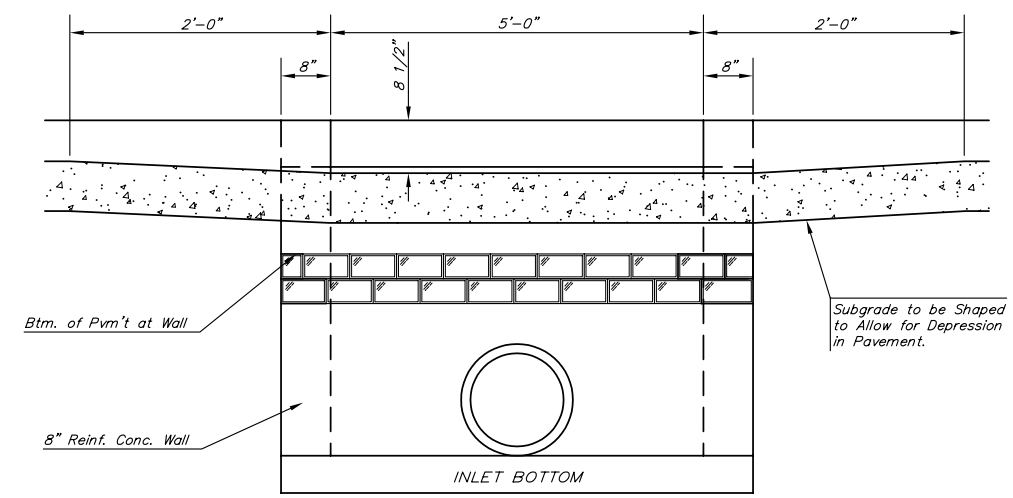

**SECTION C-C**

**STEEL SCHEDULE**

BAR	a <sub>1</sub>	a <sub>2</sub>	a <sub>3</sub>	b <sub>1</sub>					b <sub>2</sub>	b <sub>3</sub>	b <sub>4</sub>	Wt. Lbs.
				W=4'-4"	W=5'-4"	W=6'-4"	W=7'-4"	W=8'-4"				
NUMBER	4	4	2	1	3	5	7	9	6	1	1	
SIZE	#4	#4	#4	#4	#4	#4	#4	#4	#4	#4	#6	
LENGTH	W=4'-4"	5'-7"	6'-7"	4'-0"	6'-1"	-	-	-	1'-9"	6'-2"	4'-8"	60±
	W=5'-4"	7'-7"	8'-7"	5'-0"	6'-1"	-	-	-	1'-9"	6'-2"	4'-8"	81±
	W=6'-4"	9'-7"	10'-7"	6'-0"	-	6'-1"	-	-	1'-9"	6'-2"	4'-8"	101±
	W=7'-4"	11'-7"	12'-7"	7'-0"	-	-	6'-1"	-	1'-9"	6'-2"	4'-8"	121±
	W=8'-4"	13'-7"	14'-7"	8'-0"	-	-	-	6'-1"	1'-9"	6'-2"	4'-8"	141±

Note: a<sub>3</sub> Bars to be Placed Approx. 2" Below Top of Inlet Cover.

STANDARD CURB INLET PRECAST TOPS			
W	PRE-CAST TOP SIZE	PIPE SIZE	CU. YD. CONC.
4'-4"	3'-8" 6'-4" 7 1/2"	21" & SMALLER	0.38±
5'-4"	4'-8" 6'-4" 7 1/2"	24" & 30"	0.51±
6'-4"	5'-8" 6'-4" 7 1/2"	36" & 42"	0.64±
7'-4"	6'-8" 6'-4" 7 1/2"	48" & 54"	0.77±
8'-4"	7'-8" 6'-4" 7 1/2"	60" & 66"	0.90±

**GENERAL NOTES**

- Concrete tops to be installed on thin mortar cushion to insure full support along brick walls. Concrete tops may be cast in place or precast. Concrete used for inlet construction shall be concrete pavement mix.
- Contractor shall have the option of constructing 8" brick masonry walls between the concrete inlet base and top on this inlet when W=6'-4" and H=7'-0" or less.
- Inlet invert shall be shaped with 8 sack sand mix concrete to create flow channels and to increase hydraulic efficiency such that the inlet will be self cleaning between all inlet and/or outlet pipes.
- The ends of all pipes installed in inlets shall be cut off flush with the inside face of the inlet wall.

THE CITY OF WICHITA

CITY ENGINEER'S OFFICE  
CITY HALL - SEVENTH FLOOR  
455 NORTH MAIN STREET  
WICHITA, KANSAS 67202  
(316) 268-4501  
(316) 268-4114 FAX

**STANDARD TYPE 1 CURB INLET**  
**OPENING = 6" x 5'-0"**

JIM ARMOUR, P.E. - CITY ENGINEER

PROJECT NUMBER 468-84157	INDEX CODE 751431
DATE Mar 07	<b>Sheet 3 of 26</b>

G:\CIVIL\99118\DWG\SWS\PH\_20-C-3\99118\_001.DWG