

**GRADING AND DRAINAGE PLANS
FOX RIDGE ADDITION
LAKES PHASE 2C-3**

LINES 1, 1A, 1B
SHEET TITLE
468-84151
PROJECT NUMBER

DESIGN BY: DFL
DRAWN BY: KKL
CHECKED BY: GJA

ISSUED: March 2007
REVISED:

SHEET NO.
9 of 26

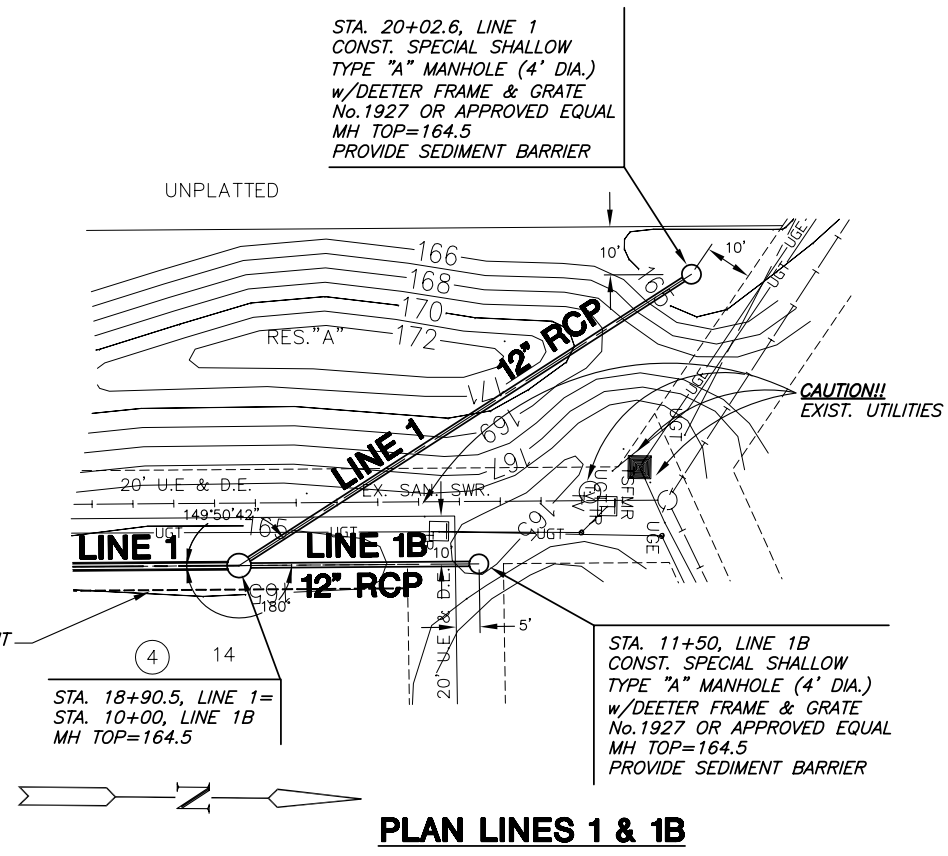

PLAN LINES 1 & 1B

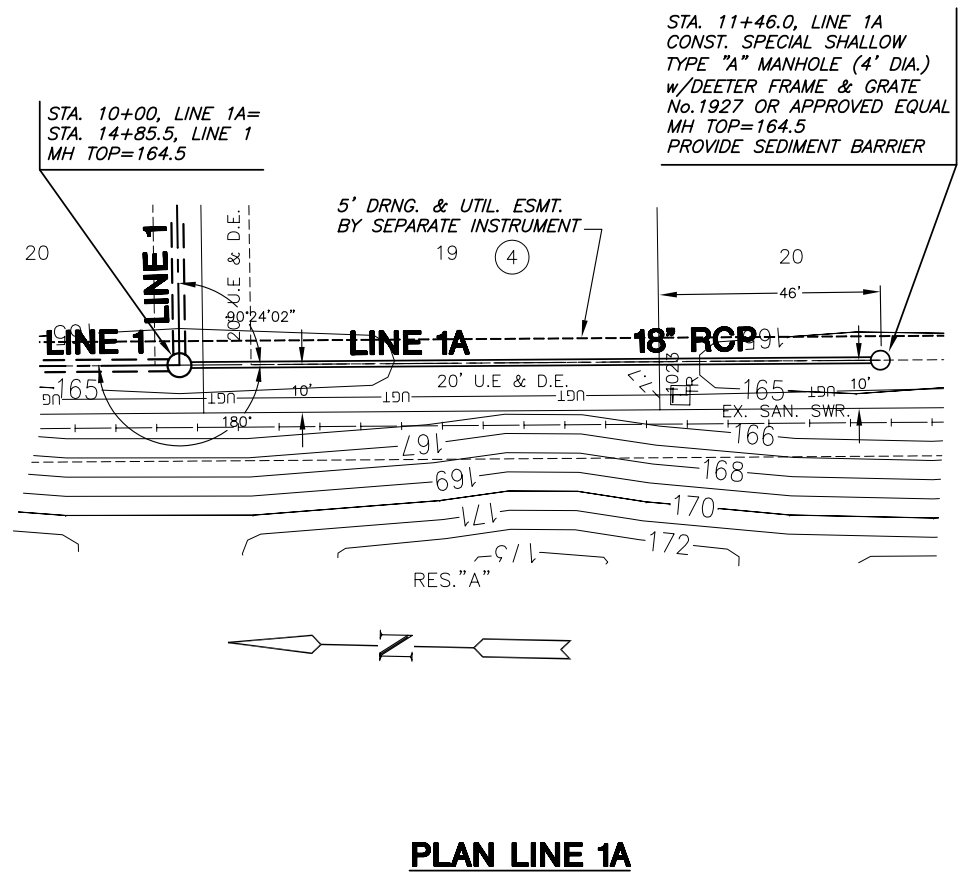

PLAN LINE 1A

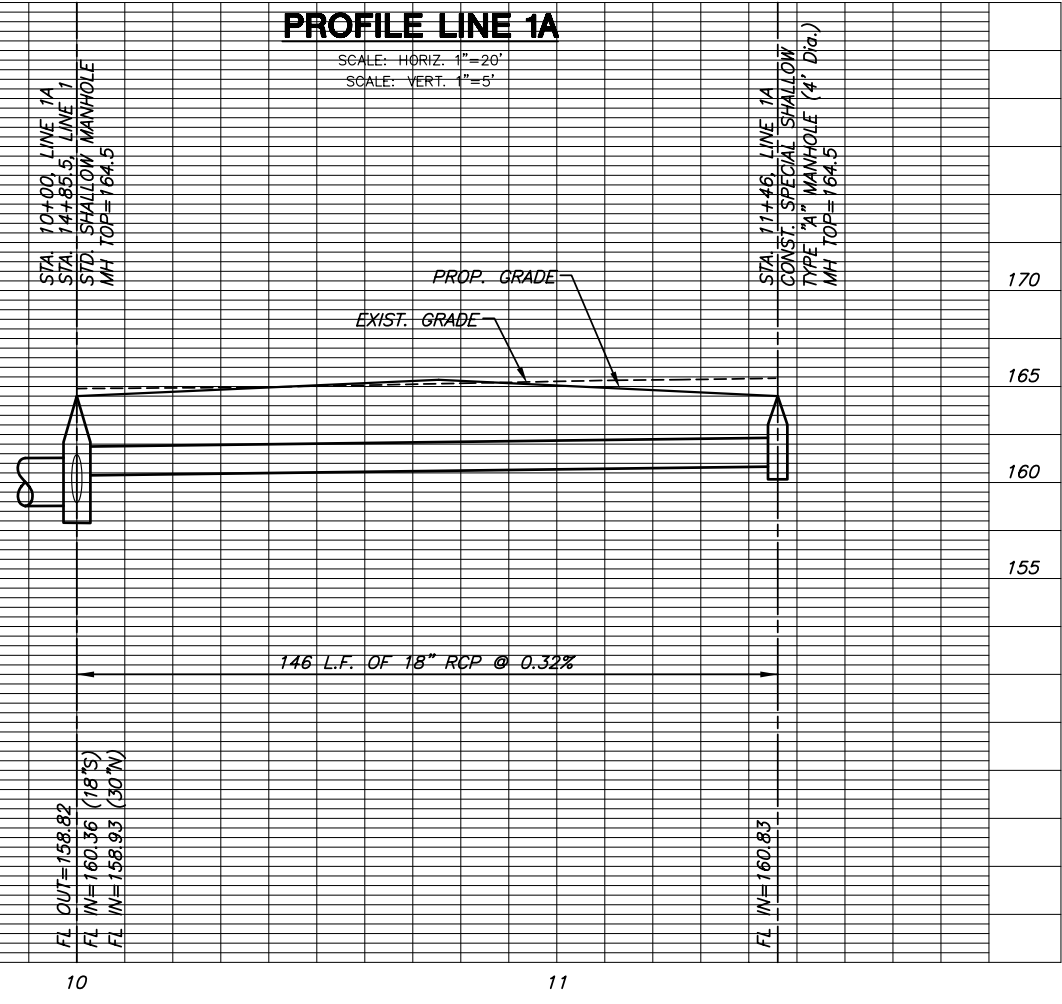
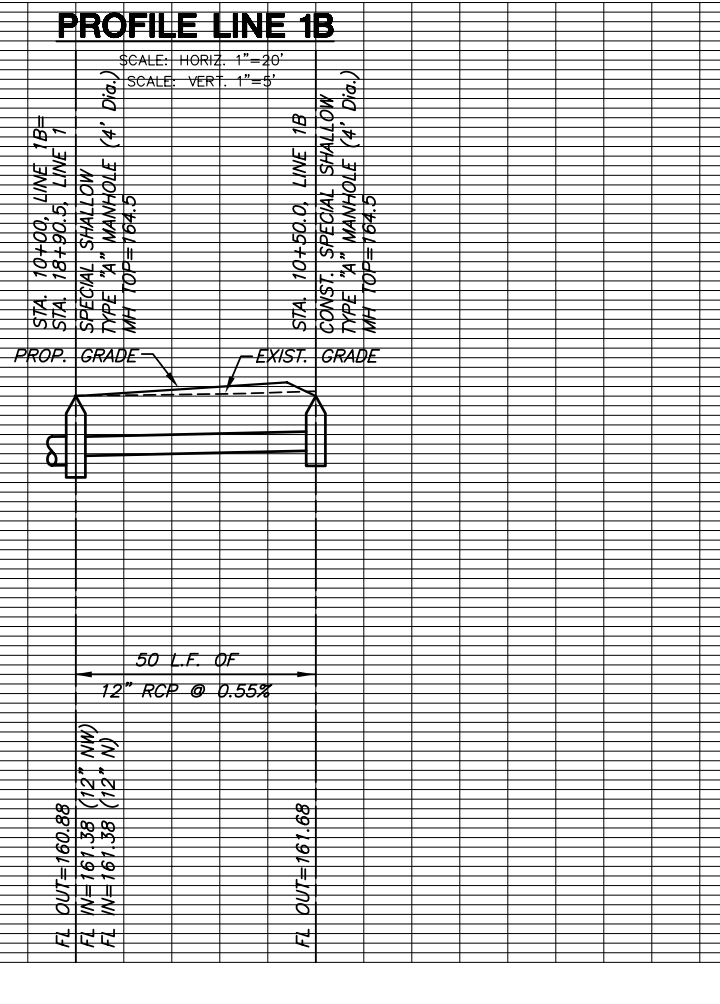
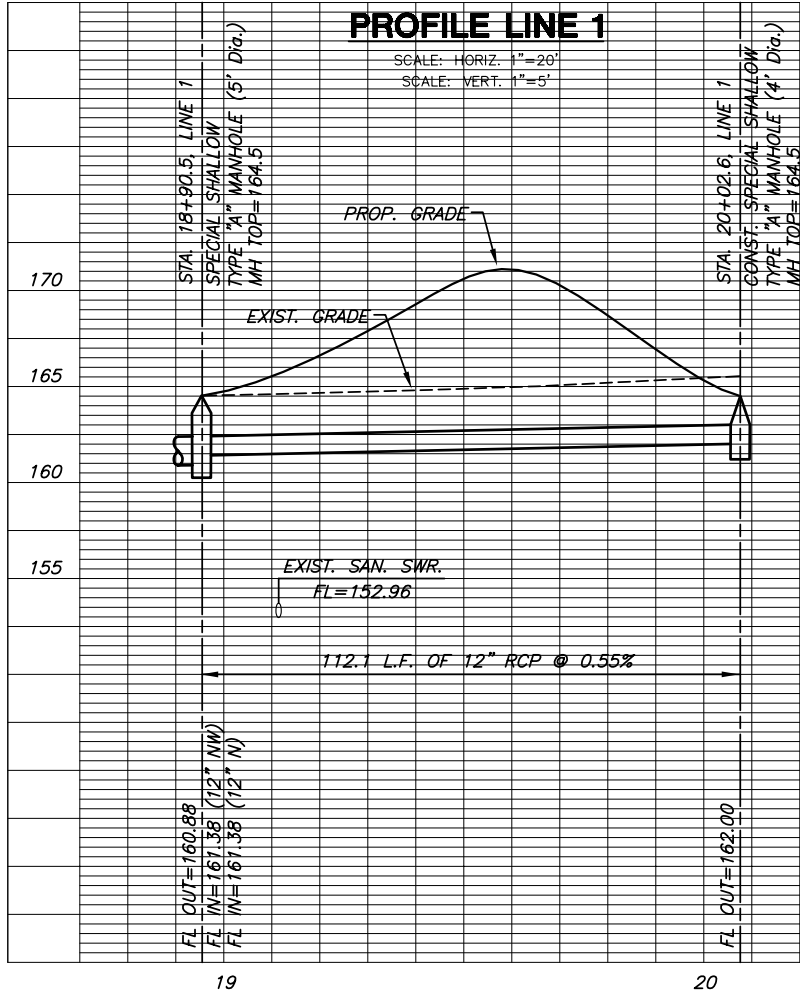

PLOTTED: Wednesday, March 07, 2007 10:34AM

G:\CIVIL\99118\DWG\SWR\PH_2C-3\99118_D3.DWG