

DRUMS AND CONICAL DELINEATORS SHALL HAVE AT LEAST TWO ORANGE AND TWO WHITE 6" TO 8" WIDE RETROREFLECTIVE STRIPES. ADDITIONAL STRIPES MAY BE NON-RETROREFLECTIVE. IF THERE ARE NON-RETROREFLECTIVE SPACES BETWEEN ADJACENT STRIPES, THEY SHALL BE NO MORE THAN 3" WIDE.

ALL RETROREFLECTIVE STRIPES ON DRUMS SHALL BE ASTM TYPE III SHEETING. THE WHITE STRIPES ON CONICAL DELINEATORS SHALL BE ASTM TYPE III SHEETING. ORANGE STRIPES ON ALL CONICAL DELINEATORS SHALL BE FLUORESCENT ORANGE ASTM TYPE IV SHEETING.

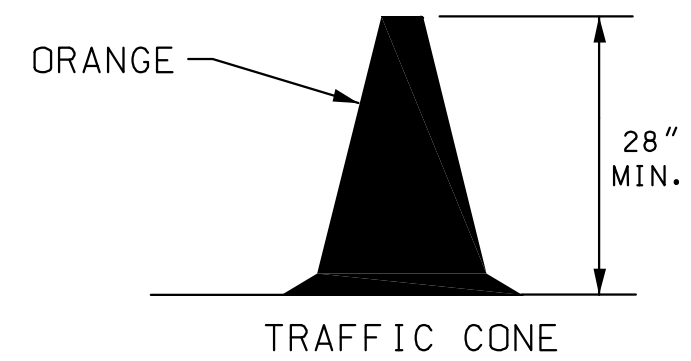

TRAFFIC CONES MAY BE USED AS CHANNELIZING DEVICES FOR DAYTIME OPERATIONS AND LOW SPEED ROADWAYS ONLY. THEY WILL NOT BE PAID FOR SEPARATELY, BUT WILL BE SUBSIDIARY TO OTHER TRAFFIC CONTROL BID ITEMS. THE ENGINEER MAY REQUIRE THAT TRAFFIC CONES BE SUPPLEMENTED BY OTHER TRAFFIC CONTROL DEVICES IN CERTAIN SITUATIONS.

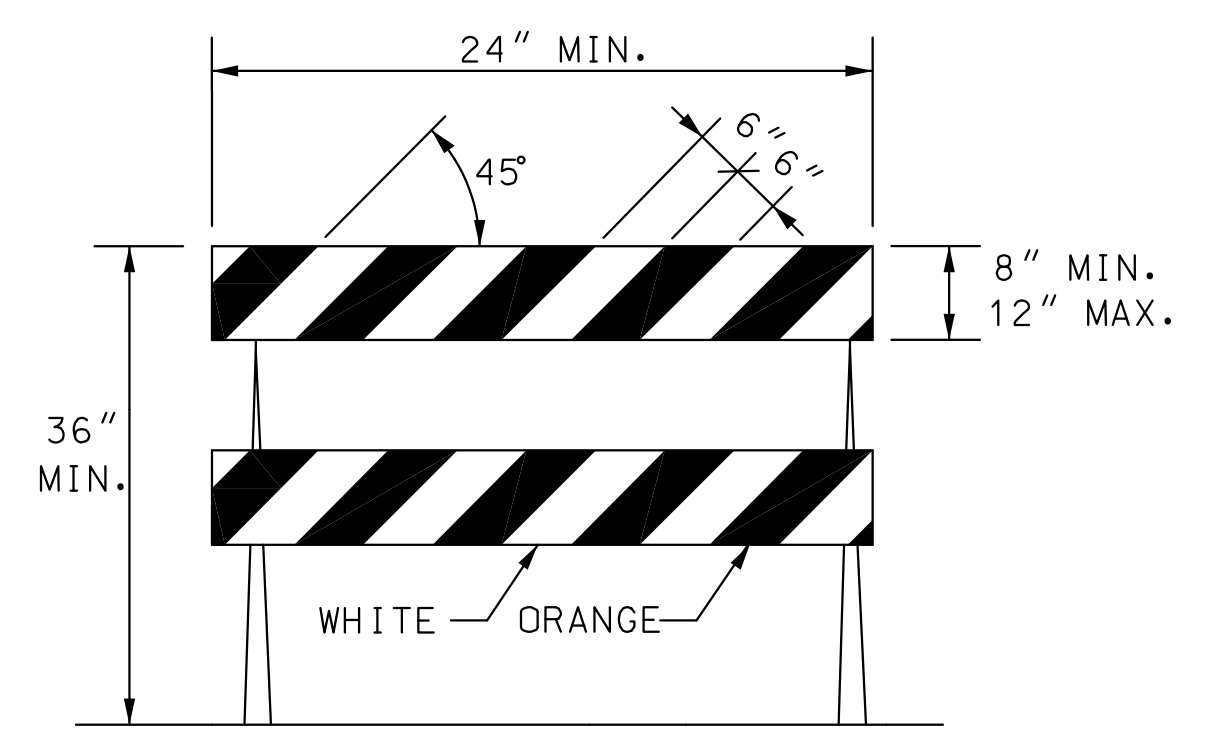

TYPE II BARRICADE

FOR RAILS LESS THAN 36" LONG, 4" WIDE STRIPES MAY BE USED.

THE ENTIRE AREA OF BARRICADE RAILS, BOTH FRONT AND BACK, SHALL BE ASTM TYPE III SHEETING.

THE STRIPES SHALL SLOPE DOWNWARD TO THE TRAFFIC SIDE FOR CHANNELIZATION.

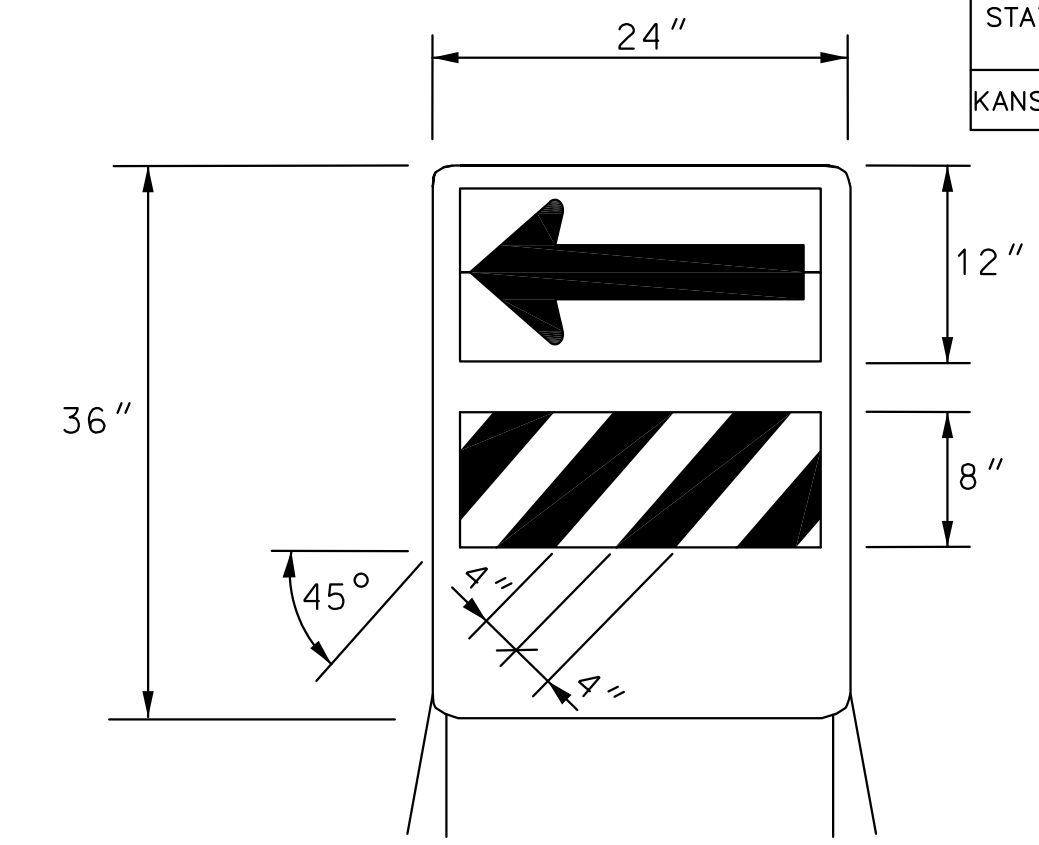

DIRECTION INDICATOR BARRICADE

THE ARROW PANEL SHALL BE BLACK ON FLUORESCENT ORANGE ASTM TYPE IV SHEETING. THE STRIPES SHALL BE ORANGE AND WHITE ASTM TYPE III SHEETING SLOPING DOWNWARD IN THE DIRECTION TRAFFIC IS TO PASS.

THE DIRECTION INDICATOR BARRICADE SHALL BE USED IN SERIES TO DIRECT THE MOTORIST INTO THE INTENDED LANE OF TRAVEL.

THE ARROW PANEL SHOULD NOT BE VISIBLE TO OPPOSING TRAFFIC.

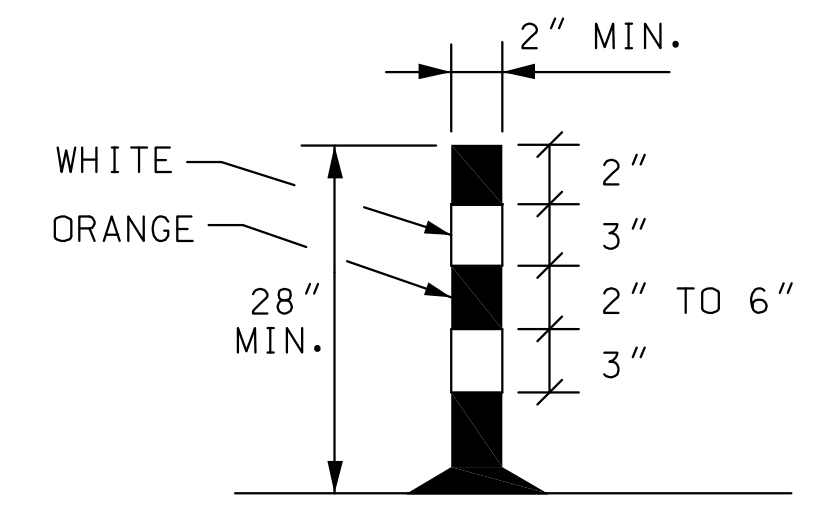

TUBULAR MARKER

THE TWO WHITE RETROREFLECTIVE STRIPES SHALL BE ASTM TYPE III SHEETING.

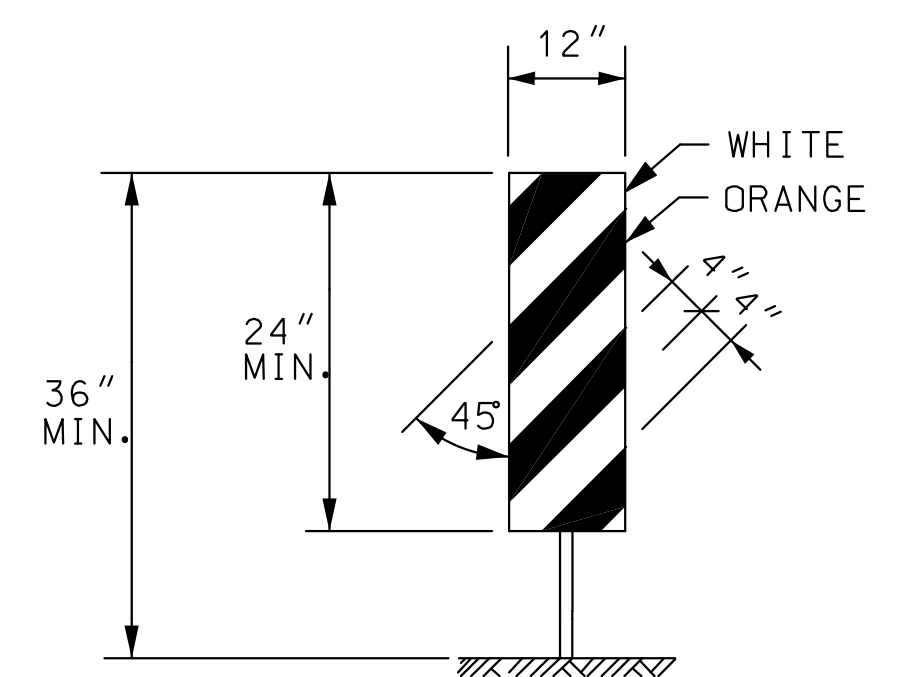

VERTICAL PANEL

THE ENTIRE AREA OF VERTICAL PANELS, BOTH FRONT AND BACK, SHALL HAVE ASTM TYPE III SHEETING. THE STRIPES SHALL SLOPE DOWNWARD TO THE TRAFFIC SIDE FOR CHANNELIZATION.

ITEM	LOCATION	LOCATION							
		CROSS-OVERS	SHOULDER DIVERSIONS	TANGENTS	TAPERS	RAMPS	HEAD TO HEAD	OBJECT IDENTIFIER	
PORTABLE	DRUMS	YES	YES	YES	YES	YES	(1)	YES	
	CONICAL DELINEATORS	YES	YES	YES	YES	YES	(1)	YES	
	VERTICAL PANELS	(2)	(2)	(2)	(2)	(2)	(1,2)	YES	
	DIRECTION INDICATOR BARRICADE	NO	NO	NO	YES	NO	NO	NO	
	TYPE II BARRICADE	(2)	(2)	(2)	(2)	NO	NO	YES	
FIXED	TUBULAR MARKERS	(3)	(3)	(3)	NO	(3)	YES	NO	
	VERTICAL PANELS	(3)	(3)	(3)	(3)	(3)	(3)	YES	

- (1) Not allowed on centerline delineation along freeways or expressways.
- (2) The stripes shall slope downward to the traffic side for channelization.
- (3) May be used upon the approval of the Engineer.

TAPER FORMULAS:

$L = WS$ FOR SPEEDS OF 45 MPH OR MORE

$L = WS^2 / 60$ FOR SPEEDS OF 40 MPH OR LESS

WHERE: L = MINIMUM LENGTH OF TAPER IN FEET
 S = NUMERICAL VALUE OF POSTED SPEED
 PRIOR TO WORK STARTING IN MPH
 W = WIDTH OF OFFSET IN FEET

CHANNELIZER PLACEMENT:

(A) THE SPACING BETWEEN DEVICES IN THE ADVANCE WARNING AREA AND THE TRANSITION AREA (TAPER) SHOULD NOT EXCEED A DISTANCE IN FEET EQUAL TO THE POSTED SPEED LIMIT IN MPH PRIOR TO WORK STARTING.

(B) THE SPACING BETWEEN DEVICES IN THE ACTIVITY AREA SHOULD NOT EXCEED A DISTANCE IN FEET EQUAL TO TWO TIMES THE POSTED SPEED LIMIT IN MPH PRIOR TO WORK STARTING.

(C) CHANNELIZING DEVICES SHALL BE PLACED FOR OPTIMUM VISIBILITY, NORMALLY AT RIGHT ANGLES TO THE TRAFFIC FLOW.

(D) CHANNELIZING DEVICES PLACED ALONG SHOULDER EDGES OR IN DROPOFFS SHALL HAVE A MINIMUM OF 24" FROM THE TOP OF THE CHANNELIZING DEVICE TO THE TOP OF THE PAVEMENT.

3	8-8-07	TRIMLINE CHANGED TO CONICAL DELINEATOR	M.B.	A.A.A.
2	11-19-03	CHANGED BORDER	B.H.	S.A.B.
1	9-26-02	MODIFIED NOTES	M.H.	S.A.B.
NO.	DATE	REVISIONS	BY	APP'D

KANSAS DEPARTMENT OF TRANSPORTATION

CHANNELIZING DEVICES

TE702 9/1/00

DESIGNED	L.E.R.	APP'D	Anthony A. Alrobaire
DETAILS	B.A.H.	QUANTITIES	TRACED
DESIGN CK.	DETAIL CK.	QUAN. CK.	TRACE CK.