

NOTES:
 1. KOOT LIGHT 18" SERIES
 2. DITCH LINER SHALL BE PLACED IN LIFTS.
 VOIDS SHALL BE COMPLETELY FILLED WITH SOIL OR SAND PRIOR TO PLACEMENT OF SUCCESSIVE LIFT.

DITCH LINER
STA 8+25 - 10+55
 NO SCALE

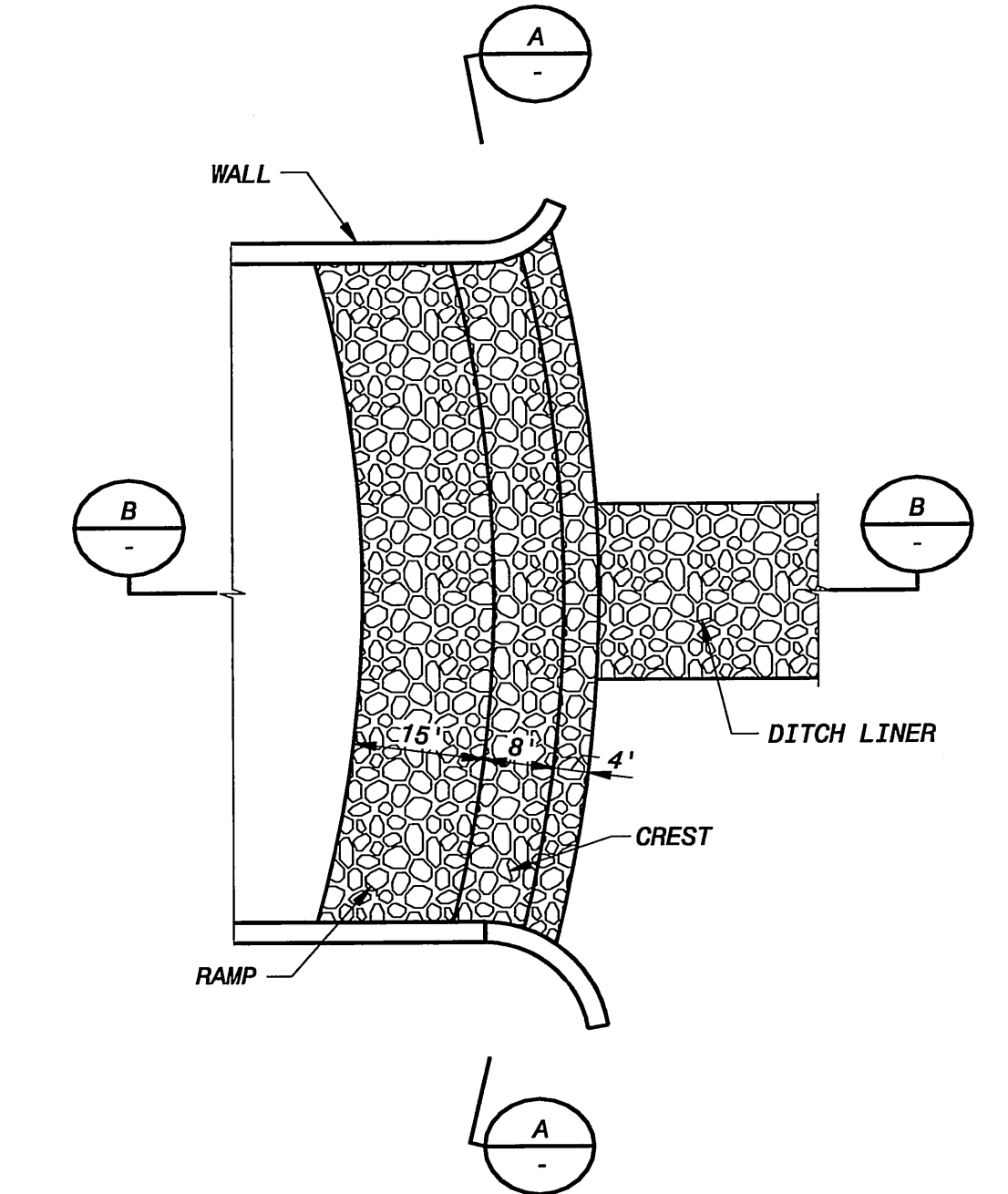

GRADE CONTROL STRUCTURE
STA 8+13.51
 NO SCALE

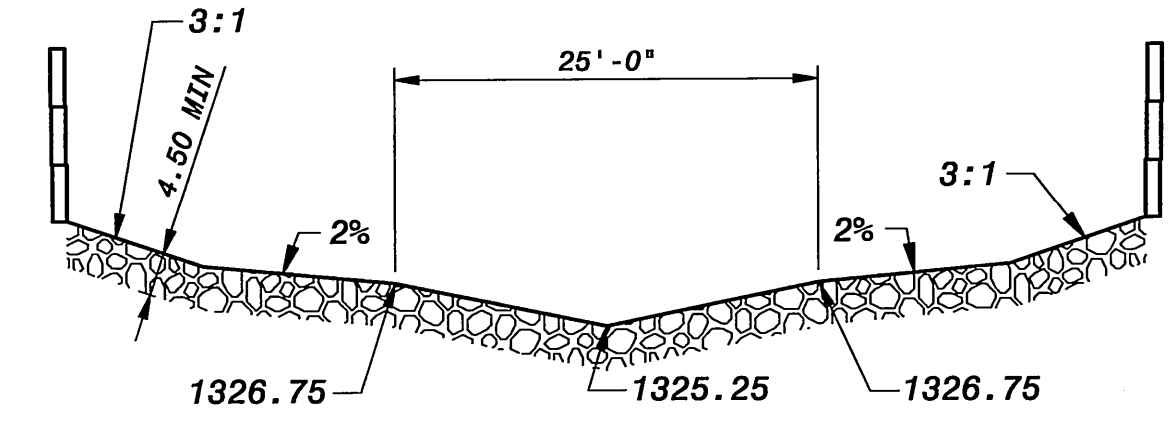

PROFILE A-A
 NO SCALE

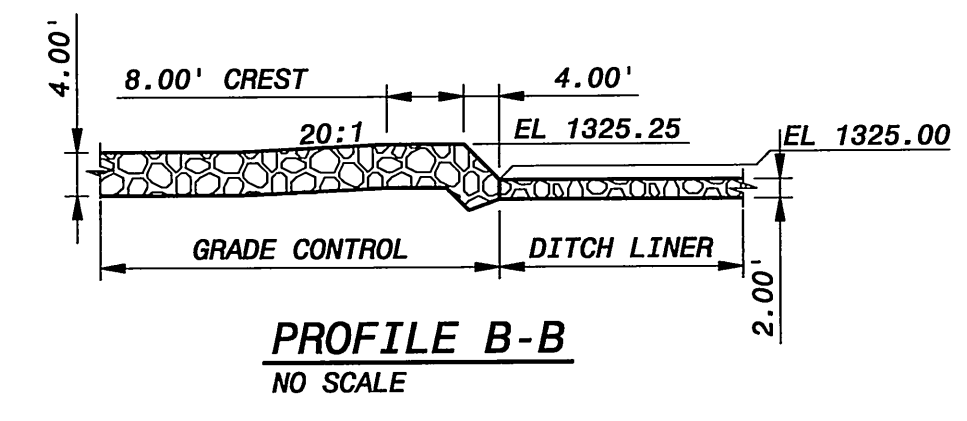

PROFILE B-B
 NO SCALE

NOTES:
 1. KOOT HEAVY SERIES 1/4 TON
 2. DITCH LINER SHALL BE PLACED IN LIFTS.
 VOIDS SHALL BE COMPLETELY FILLED WITH SOIL OR SAND PRIOR TO PLACEMENT OF SUCCESSIVE LIFT.

LEGEND

- EXISTING GRADE
- FINISHED GRADE

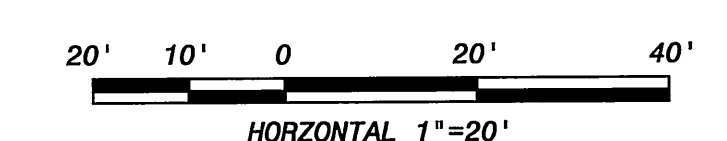

03/13/09	FINAL - CONSTRUCTION SET	4	DEC
2/13/08	100% SUBMITTAL	3	DEC
11/21/07	80% SUBMITTAL - FOR REVIEW ONLY	2	DEC
8/31/07	70% SUBMITTAL - FOR REVIEW ONLY	1	DEC
	DATE	NO.	BY
	REVISIONS AND RECORD OF ISSUE		CK APP
	CYBERNET ID: 143234-320-IMP-C-100000668		NO. BY CK APP
	REF: 0262.dwg		REF: 0262.dwg
	SAVED: 03/13/09 10:30:46 AM		REF: 0262.dwg
	PLOTTED: 03/13/09 8:56:28 AM		REF: 0262.dwg
	USER: 03/13/09		REF: 0262.dwg

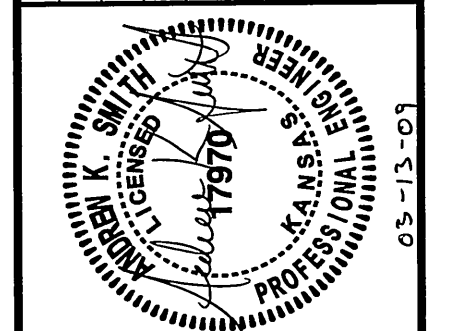

BLACK & VEATCH
 Building a world of difference
 Kansas City, Missouri

DRY CREEK CHANNEL IMPROVEMENTS
WICHITA, KANSAS
 LINCOLN TO ORME
 CROSS SECTIONS 8+50 - 10+50
 AND DETAILS

DESIGNED: HMW
 DETAILED: DEC
 CHECKED: AKS
 APPROVED:
 DATE: 13 MAR 2009

IF THIS BAR DOES NOT MEASURE 1" THEN DRAWING IS NOT TO FULL SCALE

PROJECT NO.
143234
028
 SHEET
 28 OF 42