

BENCHMARKS:

BM #1: COW Disc in top of curb adjacent to the fire hydrant at the SW corner of Yosemite and Lamp Cir.
Elev. = 146.73 (City Datum)

BM #2: COW Disc in top of curb adjacent to the fire hydrant on the west side of Westgate along the southwesterly line of Lot 13, Block B, Southern Ridge Addition.
Elev. = 144.10 (City Datum)

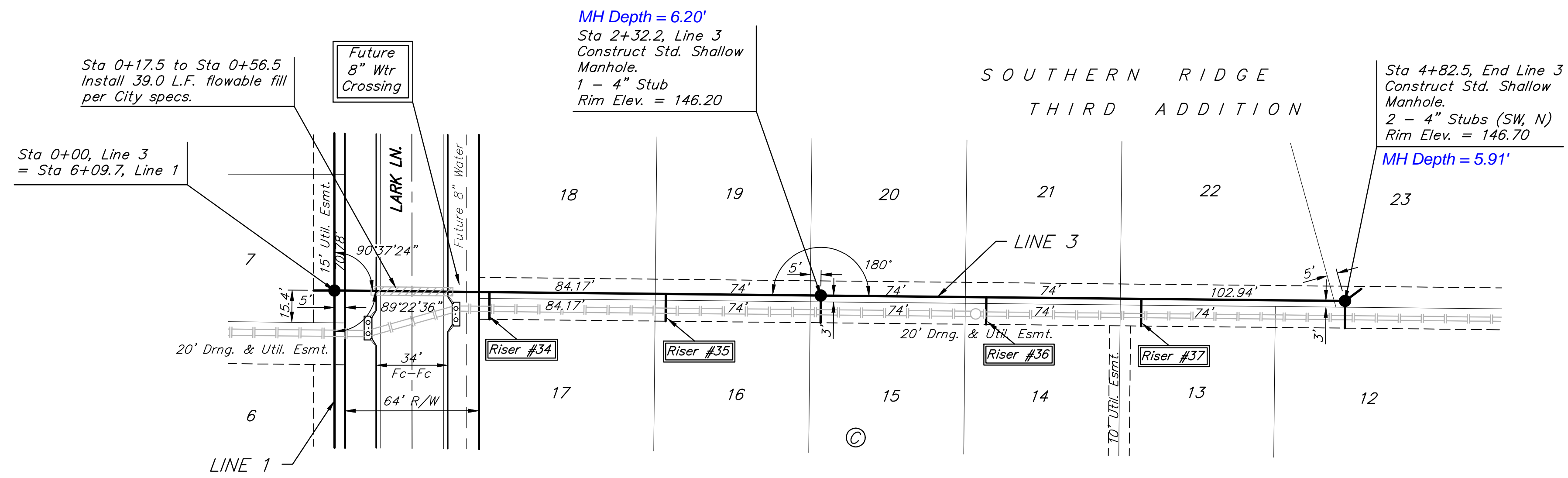

Scale: 1" = 40' Horizontal
1" = 5' Vertical
• = Iron

SEWER SERVICE TABLE

DISTANCE FROM		NUMBER	TYPE	LOCATION			FOR INFORMATION ONLY		
UPSTREAM MH	DOWNSTREAM MH			LOT NO.	BLOCK NO.	LINE NO.	STATION \ DIRECTION	APPROXIMATE LENGTH 4" PIPE	
157.2'	75'	34	8" X 4" Tee	17	C	3	0+75/Rt.	5'	13'
74.2'	158'	35	8" X 4" Tee	16	C	3	1+58/Rt.	4.5'	13'
170.5'	79.8'	36	8" X 4" Tee	15	C	3	3+12/Rt.	4.5'	13'
97.5'	152.8'	37	8" X 4" Tee	14	C	3	3+85/Rt.	4'	13'

NOTE: Vertical Riser Pipe shall be extended to 2' minimum above ground water elevation and 4' maximum below proposed ground elevation.

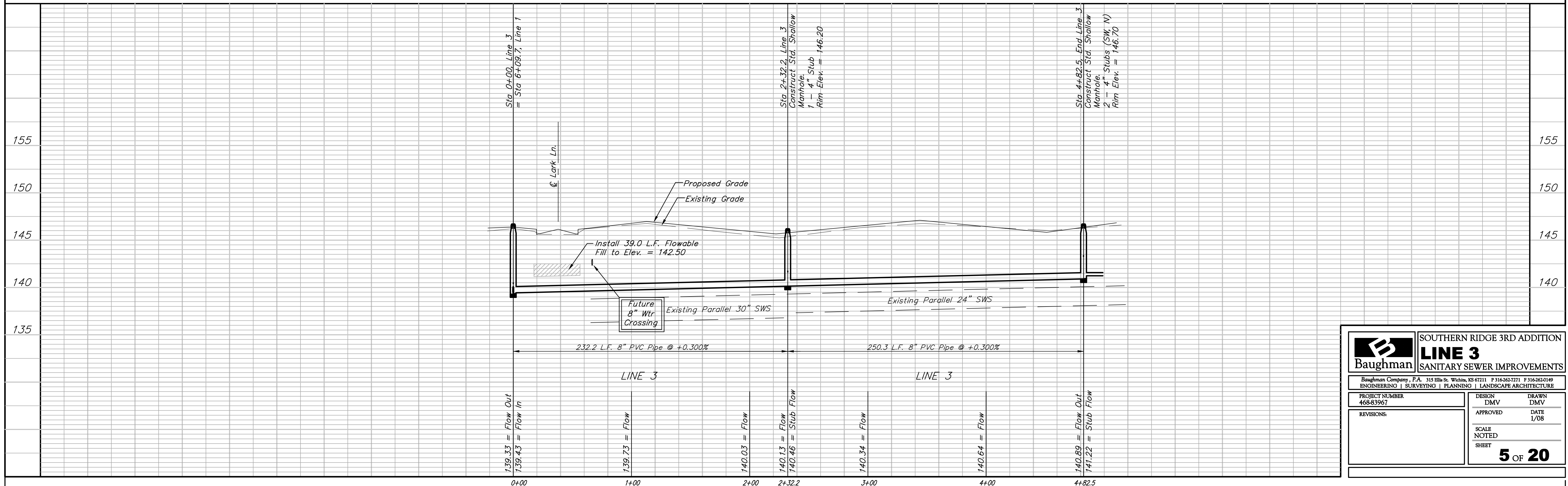

	SOUTHERN RIDGE 3RD ADDITION LINE 3 SANITARY SEWER IMPROVEMENTS	
	<small>Baughman Company, P.A. 315 Ellis St. Wichita, KS 67211 P 316-262-7271 F 316-262-0149 ENGINEERING SURVEYING PLANNING LANDSCAPE ARCHITECTURE</small>	
PROJECT NUMBER 468-83967	DESIGN DMV	DRAWN DMV
REVISIONS:	APPROVED DATE 1/08	SCALE NOTED SHEET 5 OF 20