

STATE	PROJECT NO.	YEAR	SHEET NO.	TOTAL SHEETS
KANSAS	87N-0135-01	2005	26	137

PAVING NOTES:

- SEE SHEET NO. 31 FOR JOINT DETAILS.
- CURB ELEVATIONS SHOWN ARE HIGH EDGE.
- ELEVATIONS SHOWN IN PAVING BRICK INLAY ARE FOR TOP OF PAVEMENT; DEDUCT THICKNESS OF PAVING BRICK AND BEDDING FOR ELEVATION AT TOP OF CONCRETE.
- WWF 6"x12" W4XW4 WIRE MESH SHALL BE INSTALLED IN ALL PANELS. NON-RECTANGULAR PANELS, ALL PANELS UTILIZING MONOLITHIC CURB AND ALL RECTANGULAR PANELS HAVING A WIDTH TO LENGTH RATIO OF 1:1.25 OR GREATER. SUBSIDIARY TO "CONCRETE PAVEMENT, (9") (AE)."
- THE CROSS SLOPE OF THE ASPHALT PAVEMENT AS IT APPROACHES THE CONCRETE INTERSECTION PAVEMENT SHALL TRANSITION AS REQUIRED TO MATCH THE SPOT ELEVATIONS SHOWN ON THE CONCRETE PAVEMENT.
- REFER TO MAINLINE PROFILES AND TYPICAL SECTIONS FOR ELEVATION ON EITHER SIDE OF THE INTERSECTION.
- SEE SHT. 47 FOR UTILITY FIXTURE BOX-OUT DETAILS.
- RAMPS TO BE CENTERED ABOUT CENTER OF CROSSWALKS.

CROSSWALK NOTES:

- CONCRETE UNIT PAVERS SHALL MEET OR EXCEED ASTM C 936. THE STYLE SHALL BE "HOLLAND STONE" (4"x8"x3 1/8") AS MANUFACTURED BY PAVSTONE, INC., OR EQUAL AS APPROVED BY THE ENGINEER. (ALTERNATIVE: CLAY PAVING BRICKS SHALL BE DRY PRESSED BEVEL EDGED STREET PAVERS, DESIGNED FOR HEAVY VEHICLES PER ASTM C 1272, TYPE F APPLICATION PX. SIZE SHALL BE 4"x8"x3", COMPRESSIVE STRENGTH 8,000 PSI MINIMUM, AND ABSORPTION 5% MAXIMUM). COLOR SHALL BE RED AND LAYING PATTERN SHALL BE HERRINGBONE. PAYMENT SHALL BE AT THE CONTRACT BID PRICE PER SQUARE FOOT FOR CONCRETE UNIT PAVERS.
- 8 INCH CONCRETE PAVEMENT BASE COURSE SHALL BE SUBSIDIARY TO THE BID PRICE FOR UNIT PAVER CROSSWALK.
- SAND BEDDING SHALL MEET THE SPECIFICATION REQUIREMENTS FOR FINE AGGREGATE. AN UNCOMPACTED SAND LAYING COURSE SHALL BE SPREAD EVENLY OVER THE AREA TO BE PAVED AND THEN SCREED TO A LEVEL OF APPROXIMATELY 1" MAX. THICKNESS. ONCE SCREED AND LEVELED TO THE DESIRED ELEVATION, THE SAND LAYING COURSE SHALL NOT BE DISTURBED IN ANY WAY.
- THE PAVING BRICK SHALL BE INSTALLED IN A HERRING BONE PATTERN AS SHOWN IN THE PLAN. STONES SHALL BE PLACED WITH THE CHAMFERED SIDE UP, AND JOINT SPACES KEPT UNIFORM APPROXIMATELY 1/8 INCH THICK. THE GAPS AT THE EDGE OF THE PAVED SURFACE SHALL BE FILLED WITH STONES CUT TO FIT. CUTTING SHALL BE ACCOMPLISHED TO LEAVE A CLEAN EDGE TOWARD THE TRAFFIC SURFACE, USING A MASONRY SAW. WHENEVER POSSIBLE, NO CUTS SHOULD RESULT WITH A PAVER LESS THAN ONE-THIRD OF ITS ORIGINAL DIMENSION.
- PAVING BRICK SHALL BE VIBRATED TO THEIR FINAL LEVEL IN THE SAND LAYING COURSE BY TWO OR THREE PASSES OF A VIBRATING COMPACTOR CAPABLE OF 3000 TO 5000 POUNDS COMPACTION FORCE WITH THE SURFACE CLEAN AND JOINTS OPEN.
- AFTER VIBRATION, CLEAN CONCRETE SAND SHALL BE SPREAD OVER THE PAVING STONE SURFACE, ALLOWED TO DRY, AND VIBRATED INTO THE JOINTS WITH ADDITIONAL PASSES OF THE PLATE VIBRATOR SO AS TO COMPLETELY FILL THE JOINTS. A LIGHT COATING OF SAND SHALL BE SWEEPED OVER THE COMPLETED SURFACE AND LEFT TO WEATHER IN.

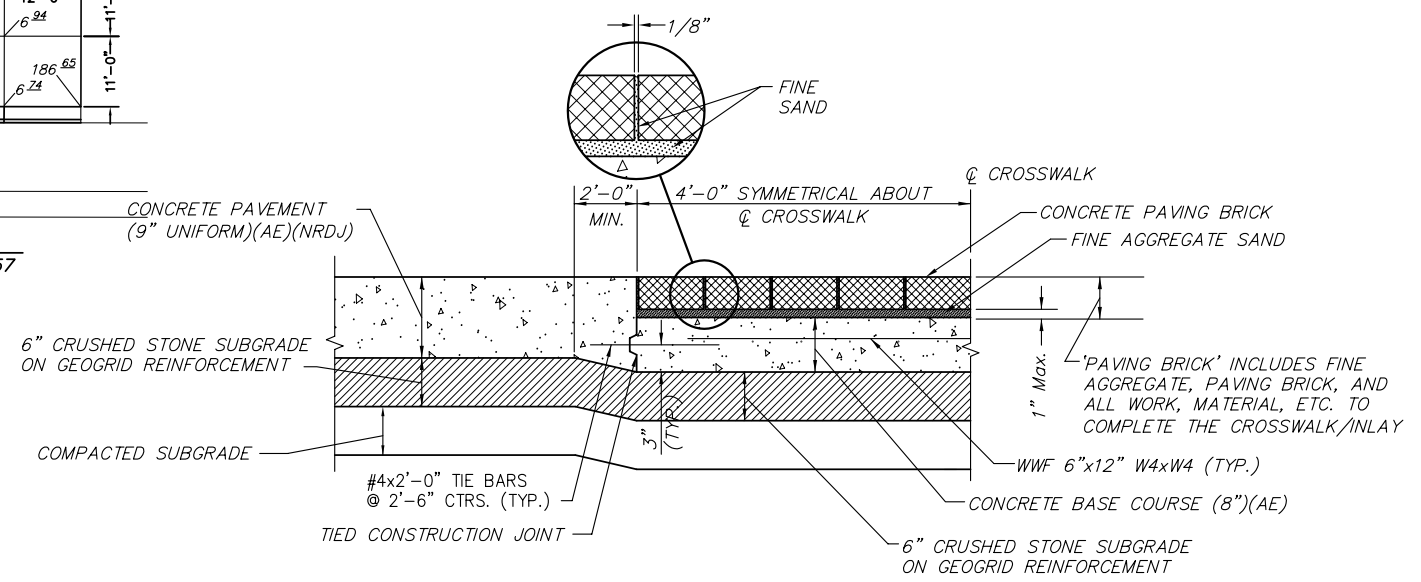
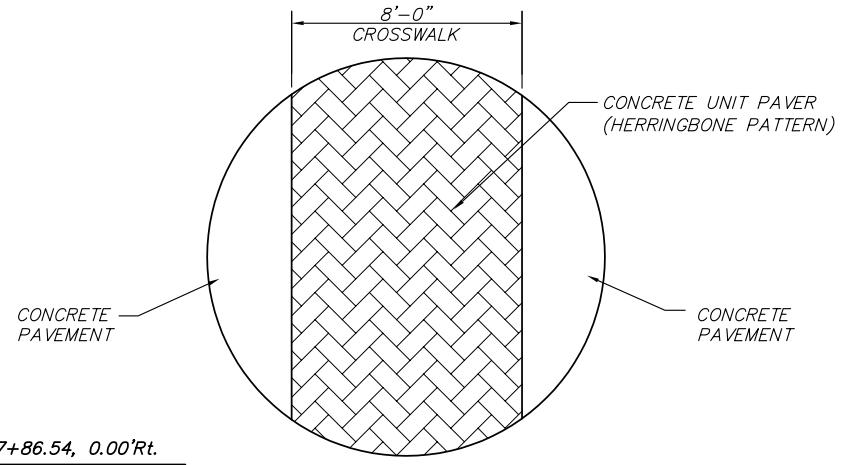
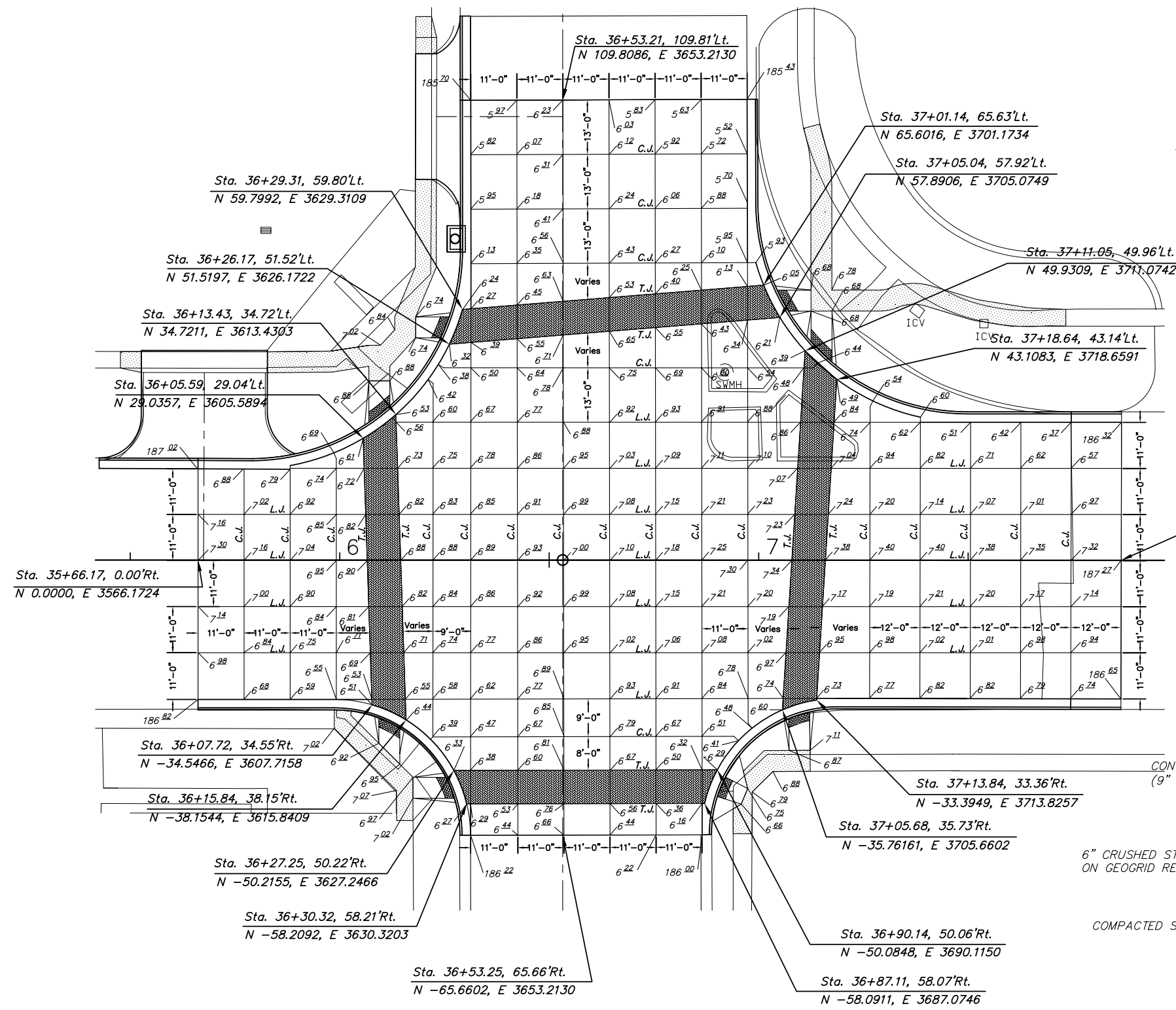
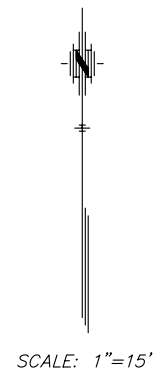

CROSSWALK DETAILS

**LEGEND**

TJ	TIED CONSTRUCTION JOINT
LJ	LONGITUDINAL JOINT
CJ	CONTRACTION JOINT

H:\CIVIL\03149\dwg\pave\03149INTER.dwg 02/27/2006 05:25:11 PM CST

KANSAS DEPARTMENT OF TRANSPORTATION  
**CENTRAL & EDGEMOOR  
 MEDIAN PAVERS AND BRICK PAVER  
 CROSSWALKS**  
 PROJECT NO. 87 N-0135-01 SEDGWICK CO.  
**M K E C ENGINEERING CONSULTANTS, INC.**  
 WICHITA, KANSAS

DESIGNED BY: JRA	CHECKED BY: JRA
DRAWN BY: WNJ	DATE: DEC. 2005 SHEET 26 OF 137