

SECTION A-A

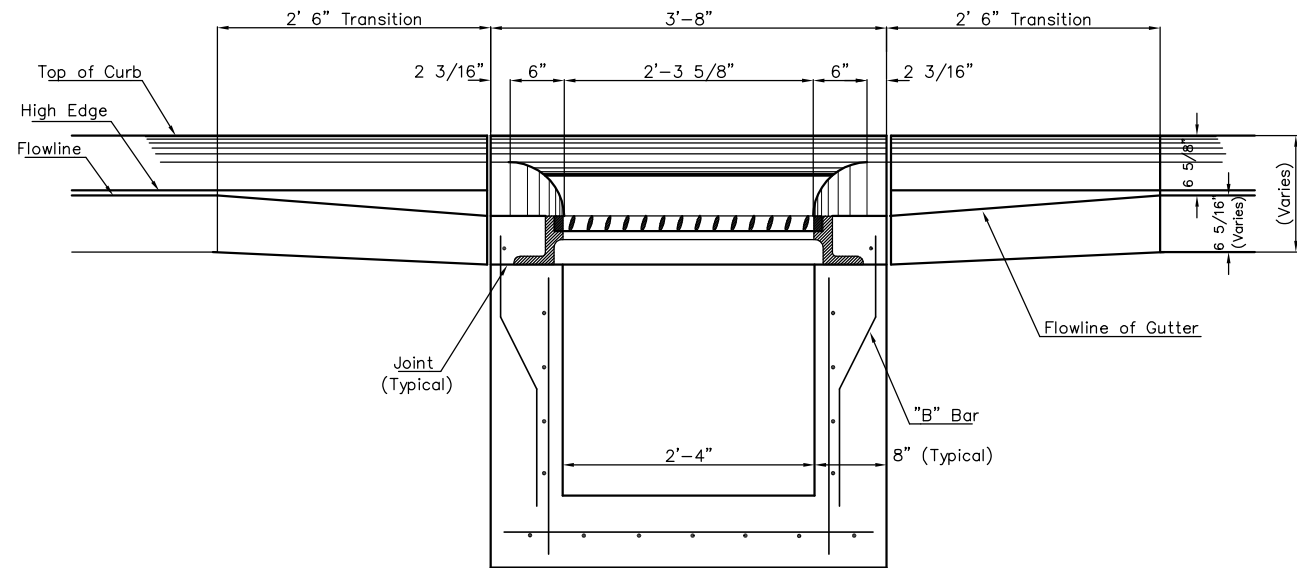

SECTION C-C

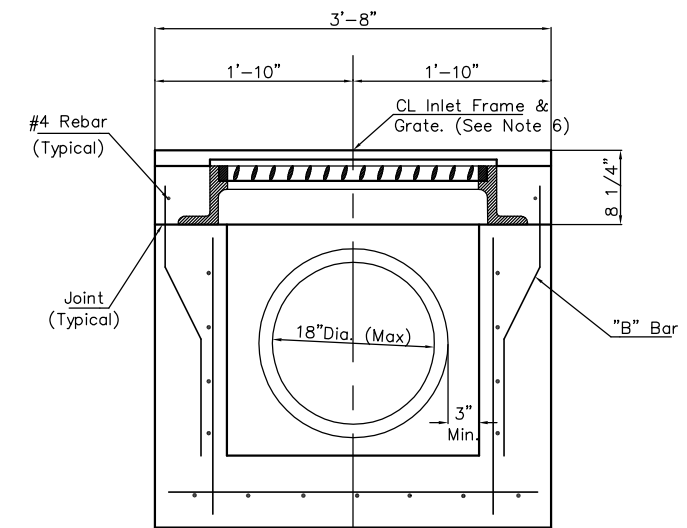

SECTION D-D

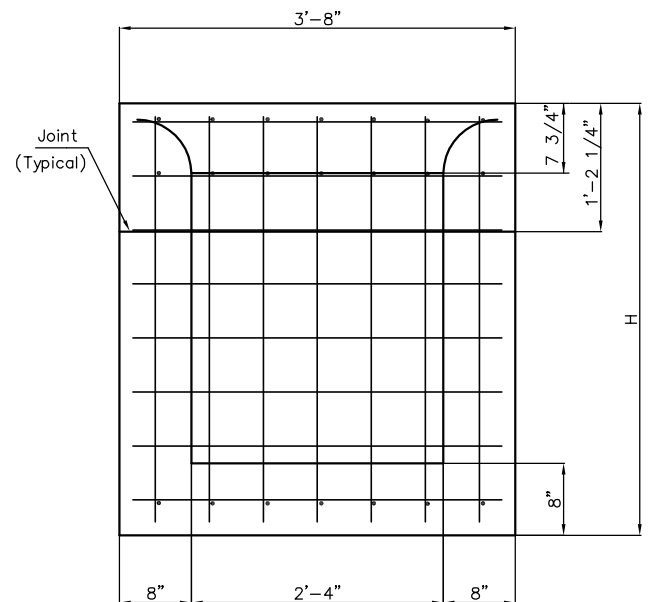

REAR WALL

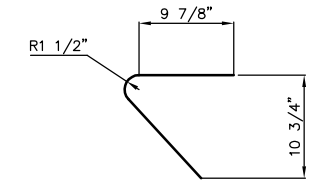
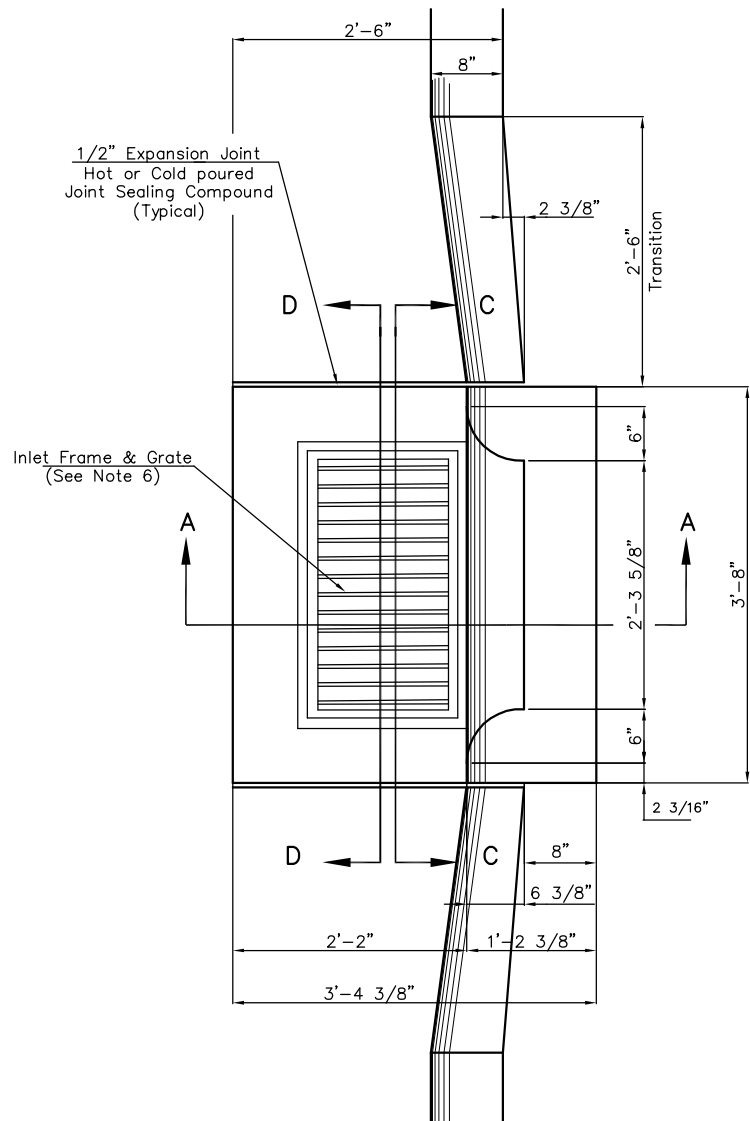

"A" Bar

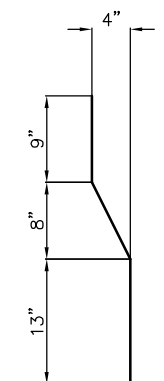

"B" Bar

**General Notes**

1. Use the concrete mix specified for the City of Wichita concrete pavement throughout. All exposed edges shall be finished with an edging tool. Reinforcing bars shall be bent around pipe.
2. Inlet invert shall be shaped with 8 sack mix concrete to create flow channels and to increase hydraulic efficiency such that the inlet will be self cleaning between all inlet and/or outlet pipes.
3. All bars are #4 with 6" spacing and shall have a minimum clearance of 1 1/2" inches unless otherwise noted on the plans.
4. When directed by the Engineer, a small opening may be required in the back of the inlet in order to drain a low area. Reinforcing bars will extend through the openings. No deductions in concrete quantities will be made for these openings.
5. No deductions will be made in pay length of curb, gutter, or curb and gutter through the inlet area.
6. Use Neenah R-3289 HV Single Inlet Frame and Grate or approved equal. Inlet frame to be proof load tested to 40,000 lbs. on unsupported side.
7. Reinforcing bars shall be cut or bent around pipes. No deduction in concrete quantities shall be made for pipe openings.
8. The vanes of the grate shall be oriented with respect to the flow arrows shown on the plans.

H:\CML\03149\dwg\Details\Std Type 2 Inlet.dwg 03/01/2006 01:48:11 PM CST

<p>THE CITY OF WICHITA</p> <p>CITY ENGINEER'S OFFICE CITY HALL - SEVENTH FLOOR 455 NORTH MAIN STREET WICHITA, KANSAS 67202 (316) 268-4501 (316) 268-4114 FAX</p>	<p><b>STANDARD TYPE II CURB INLET</b></p> <p><b>INLET OPENING = 6" x 2'-3 5/8"</b></p>	
	<p>JIM ARMOUR, P.E. - CITY ENGINEER</p>	
<p>PROJECT NUMBER 472-83873</p>	<p>INDEX CODE 706871</p>	
<p>DATE MAR 96</p>	<p>SHEET 46A OF 137</p>	