

**REINFORCED CONCRETE ENCASEMENT OF SANITARY SEWER**

PIPE SIZE	THRUST AT FITTINGS IN TONS-AT 150#/IN <sup>2</sup> P					
	PLUG	90°	45°	22 1/2°	11 1/4°	TEE
6"	2.8	3.95	2.15	1.09	.55	2.8
8"	4.9	6.95	3.75	1.90	.96	4.9
12"	11.4	16.1	8.75	4.45	2.25	11.4
16"	20.15	28.5	15.4	7.85	3.95	20.15
20"	31.15	44.0	23.85	12.15	6.10	31.15
24"	44.55	63.0	34.1	17.4	8.75	44.55

**TYPICAL THRUST BLOCKS**

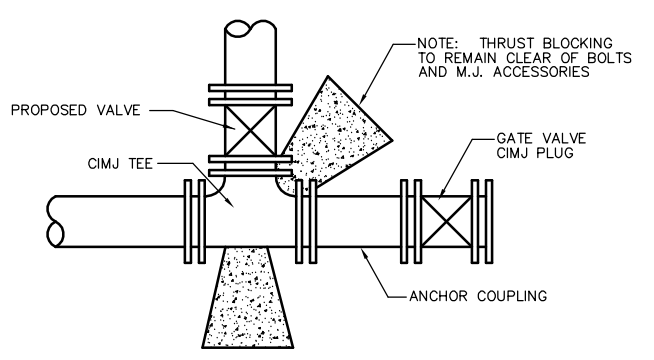

**KEY BLOCK DETAIL**

**SETTLEMENT & COMPACTION ON CITY AND COUNTY ROAD RIGHT-OF-WAY EXCEPT UNDER PAVEMENT**

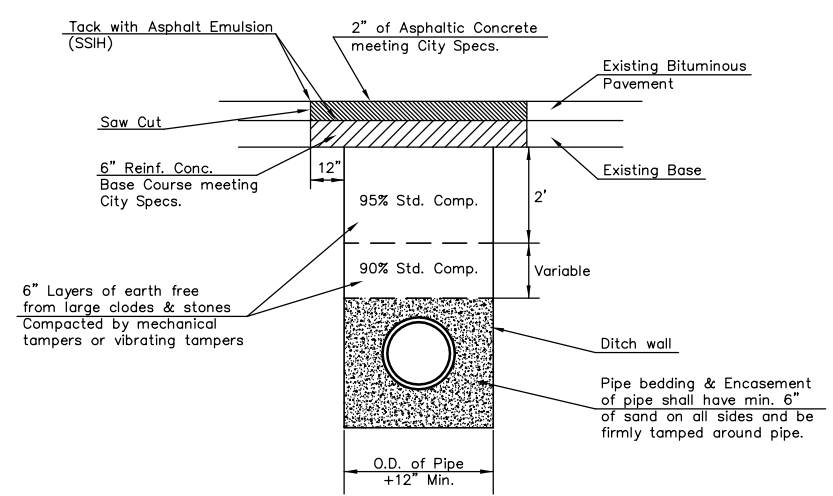

Standard Density Test, as described in the latest addition of ASTM D698, shall be performed to verify the above requirements to the Satisfaction of the Sedgwick County Director of Public Works. All testing cost shall be included in the unit price bid for the pipe in place.

When laying under paving, parallel with the centerline of the street, a minimum of one (1) Standard Density Test shall be performed on each 300 lineal feet of ditch.

**PAVEMENT REPLACEMENT & DITCH COMPACTION UNDER EXISTING AND PROPOSED CITY ROADS**

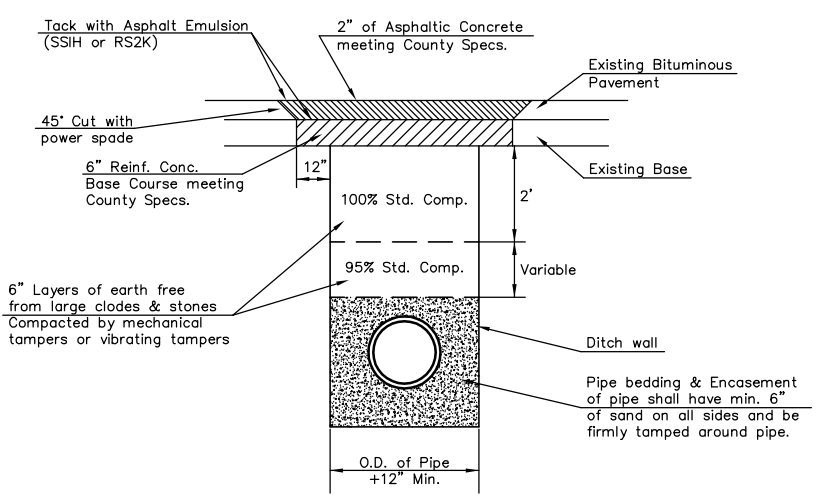

Standard Density Test, as described in the latest addition of ASTM D698, shall be performed to verify the above requirements to the Satisfaction of the Sedgwick County Director of Public Works. All testing cost shall be included in the unit price bid for the pipe in place.

When laying under paving, parallel with the centerline of the street, a minimum of one (1) Standard Density Test shall be performed on each 300 lineal feet of ditch.

**PAVEMENT REPLACEMENT & DITCH COMPACTION UNDER EXISTING AND PROPOSED COUNTY ROADS**

REVISED APR 97

**THE CITY OF WICHITA**

**VARIOUS WATER DETAILS**

JIM ARMOUR, P.E. - CITY ENGINEER

CITY ENGINEER'S OFFICE  
CITY HALL - SEVENTH FLOOR  
455 NORTH MAIN STREET  
WICHITA, KANSAS 67202  
(316) 268-4501  
(316) 268-4114 FAX

PROJECT NUMBER 472-83873	INDEX CODE 620377
DATE DEC 05	SHEET 81 OF 137