

TYPICAL 35' B-B PAVEMENT DETAILS

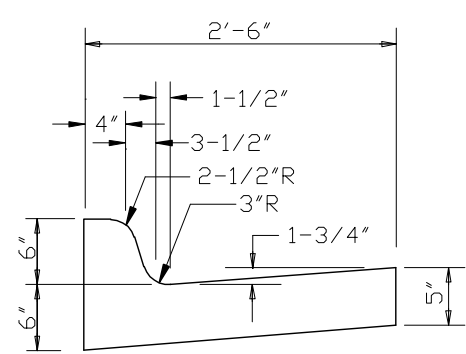

STATE CURB
MODIFIED TYPE I
COMBINED CURB & GUTTER

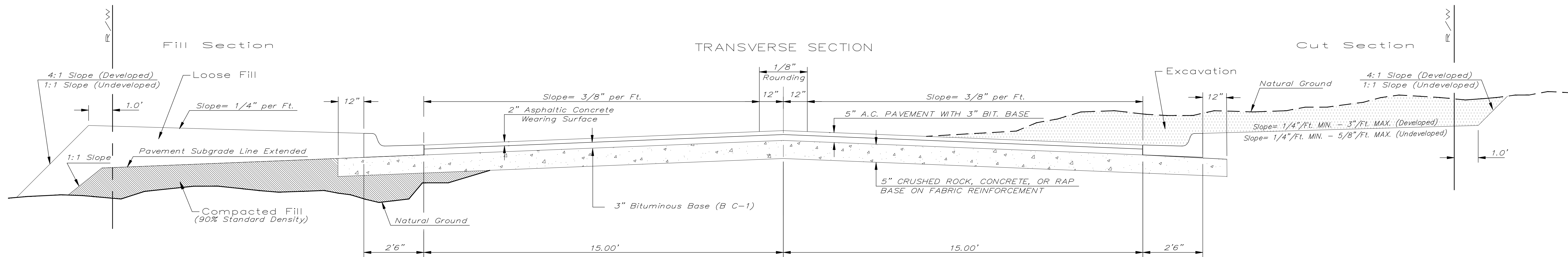
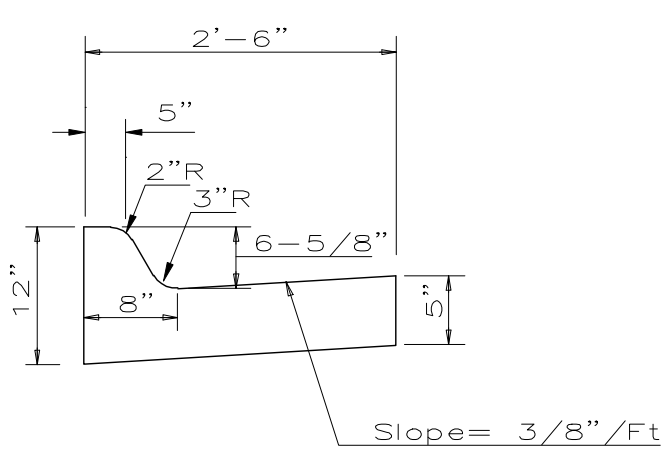

COMBINED CURB & GUTTER

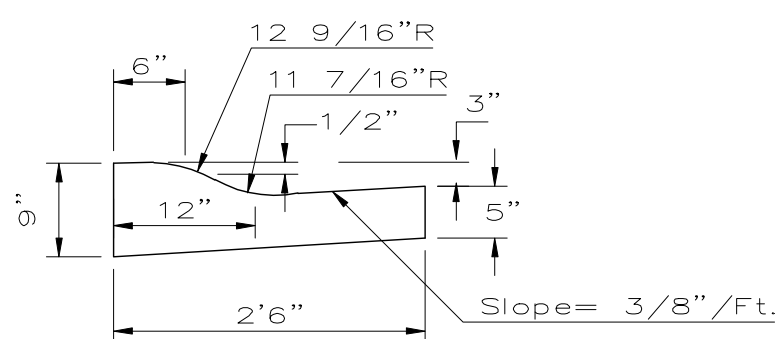

COMBINED ROLL TYPE CURB & GUTTER



	0'	2'	4'	6'	8.5'	10'	12'	14'	15'	17'	17.5'	18.5'
A: Top of Curbs to Top of Surface Lift	0.04	0.08	0.14	0.21	0.29	0.33	0.39	0.46	0.49	-	-	-
B: Top of Curbs to Top of Upper Base Lift	0.21	0.25	0.31	0.37	0.45	0.50	0.56	0.62	0.65	-	-	-
C: Top of Curbs to Top of C. R. Subgrade	0.46	0.50	0.56	0.63	0.71	0.75	0.81	0.88	0.91	0.97	0.98	1.01

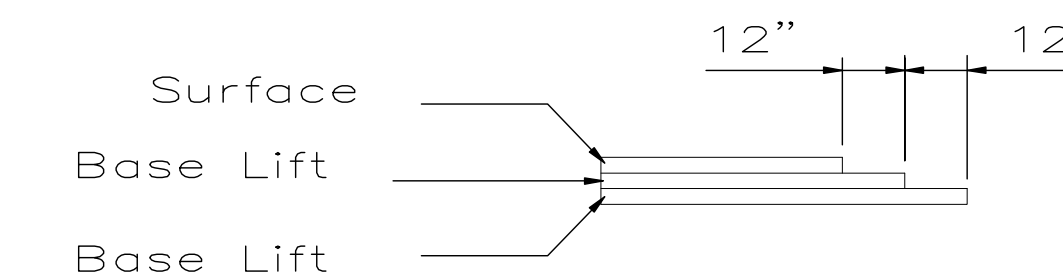

TRANSVERSE CONSTRUCTION JOINTS

Transverse construction joints shall be constructed in flexible base pavements at locations where pavement joins existing flexible base pavement as shown by the detail. All costs associated with the construction of the transverse joint shall be included in the bid price for Square Yards 5" ASPHALTIC CONCRETE (3" BITUMINOUS BASE).

General Notes

FABRIC BASE REINFORCEMENT SHALL BE B X 1100 GEOTEXTILE AS MANUFACTURED BY TENSAR CORPORATION OR APPROVED EQUAL. FABRIC BASE REINFORCEMENT SHALL BE INSTALLED IN ACCORDANCE WITH MANUFACTURER'S RECOMMENDATIONS. CRUSHED ROCK SHALL BE UNIFORMLY GRADED FROM 1-1/2" MAXIMUM SIZE TO NOT MORE THAN 10% PASSING A NO. 200 SIEVE. ROCK QUALITY SHALL BE THE SAME AS SPECIFIED FOR COARSE AGGREGATE FOR CONCRETE MIXES.

ROCK BASE IS TO BE COMPACTED AND SMOOTHED WITH A STEEL FACED ROLLER PRIOR TO PLACEMENT OF ASPHALT. TACK COAT WILL NOT BE APPLIED TO ROCK BASE.

A TACK COAT OF EMULSIFIED ASPHALT (SC-1H OR CSS-1H) SHALL BE APPLIED AT AN APPROXIMATE RATE OF 0.05 GALLONS PER SQUARE YARD BETWEEN EACH LIFT OF ASPHALTIC MATERIAL.

BITUMINOUS BASE AND ASPHALTIC CONCRETE WEARING SURFACE SHALL BE PLACED WITH A LAYDOWN MACHINE HAVING AUTOMATIC CONTROLS FOR LINE AND GRADE.

CONSTRUCTION JOINTS IN EACH LIFT SHALL BE STAGGERED A MINIMUM DISTANCE OF ONE (1) FOOT FROM JOINTS IN PRECEDING LIFTS AND PLACED SO THAT A JOINT WILL BE CONSTRUCTED ON THE CENTERLINE OF THE TOP LIFT.

THE ASPHALTIC CONCRETE PAVEMENT BETWEEN THE COMBINED CURB AND GUTTER SHALL BE PAID AS SQUARE YARDS OF 5" ASPHALTIC CONCRETE (3" BITUMINOUS BASE).

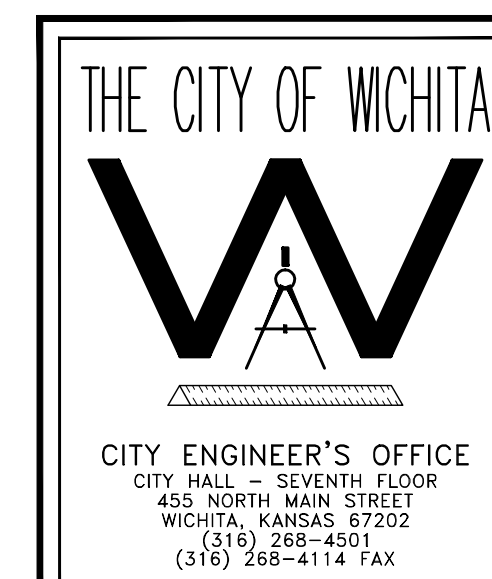

CITY ENGINEER'S OFFICE
CITY HALL - SEVENTH FLOOR
455 NORTH MAIN STREET
WICHITA, KANSAS 67202
(316) 268-4501
(316) 268-4114 FAX

35' PAVEMENT
5" ASPHALTIC CONCRETE
W/ CRUSHED ROCK BASE

PROJECT NUMBER 448-90406	OCA #
DATE	SHEET 2 OF 23