

EXPANSION JOINT

NOTE: Extra Thickness to be Subsidiary to Price of Square Yards Pavement

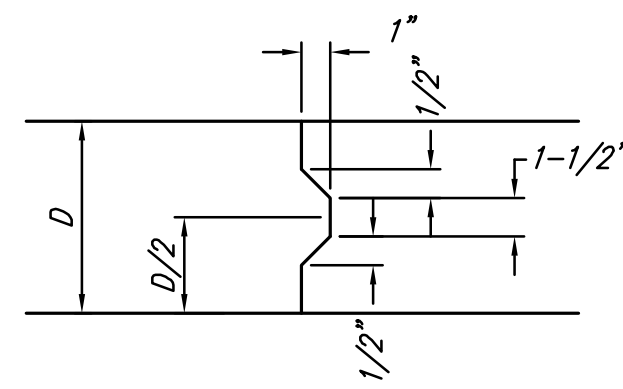

KEYWAY DETAIL

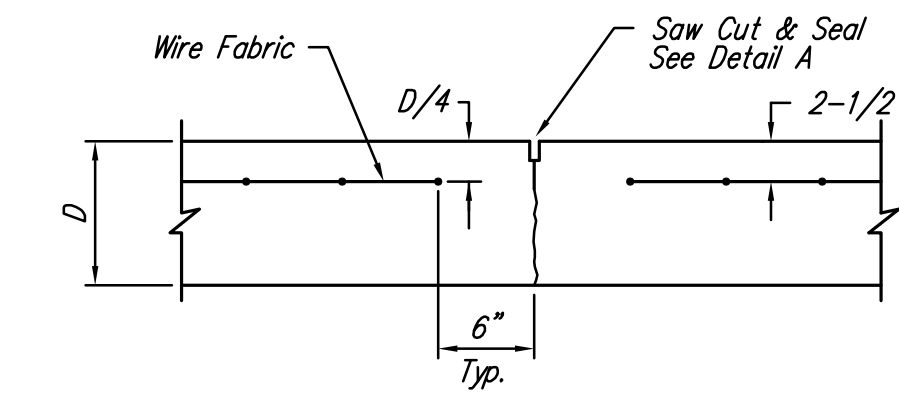

CONTRACTION JOINT DETAIL (C.J.)

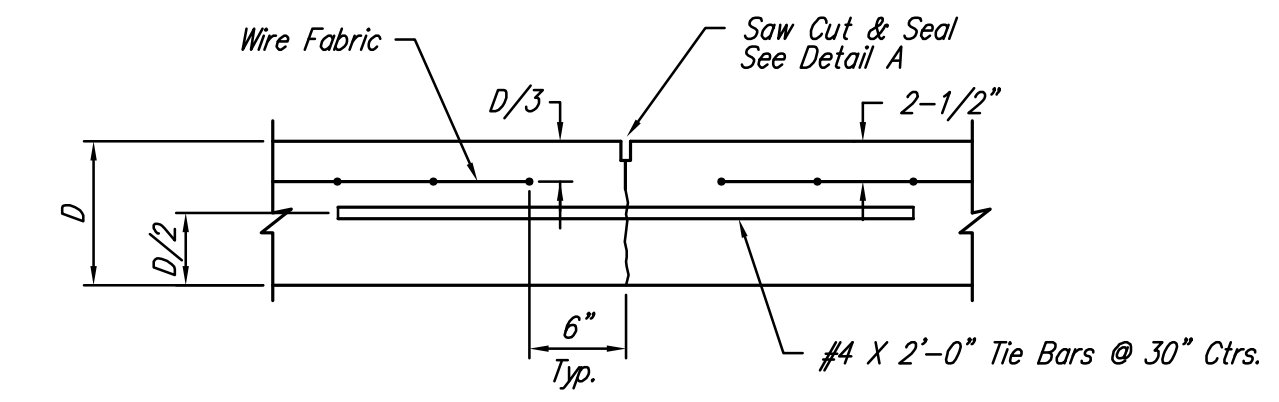

LONGITUDINAL JOINT DETAIL (L.J.)

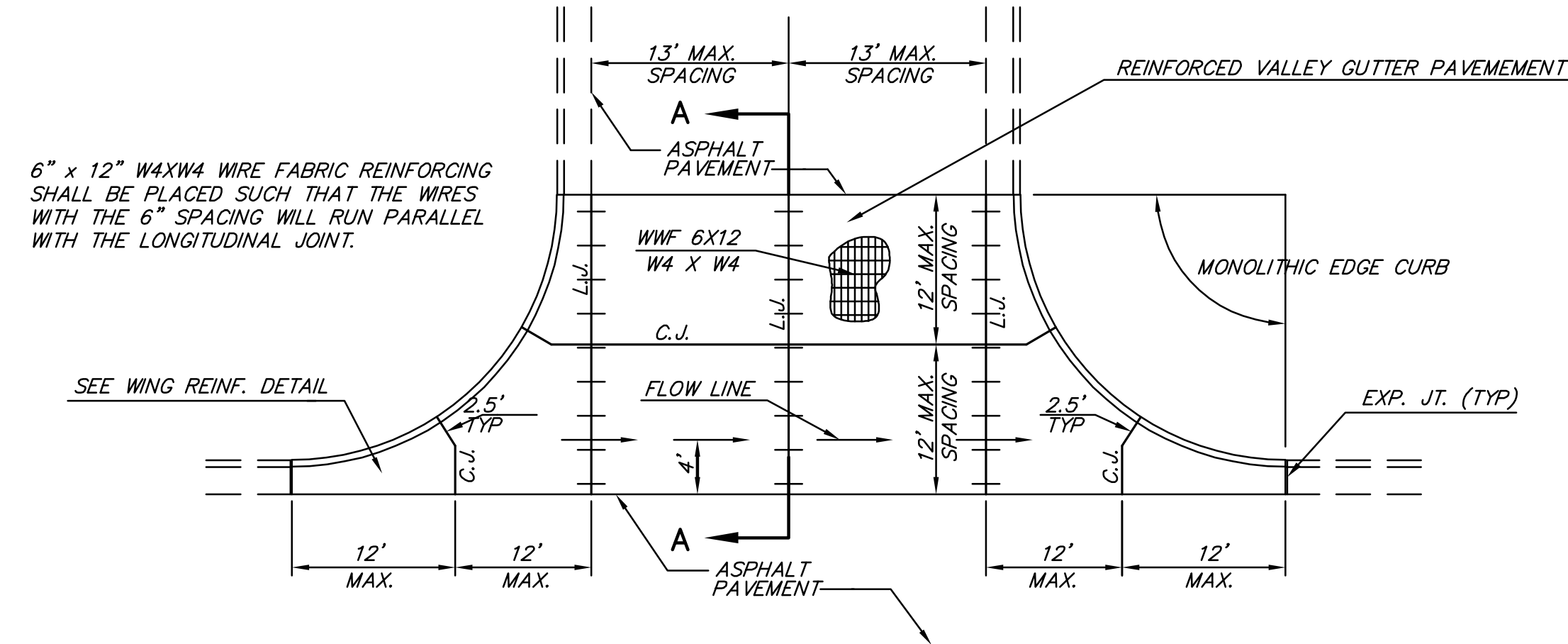

PLAN

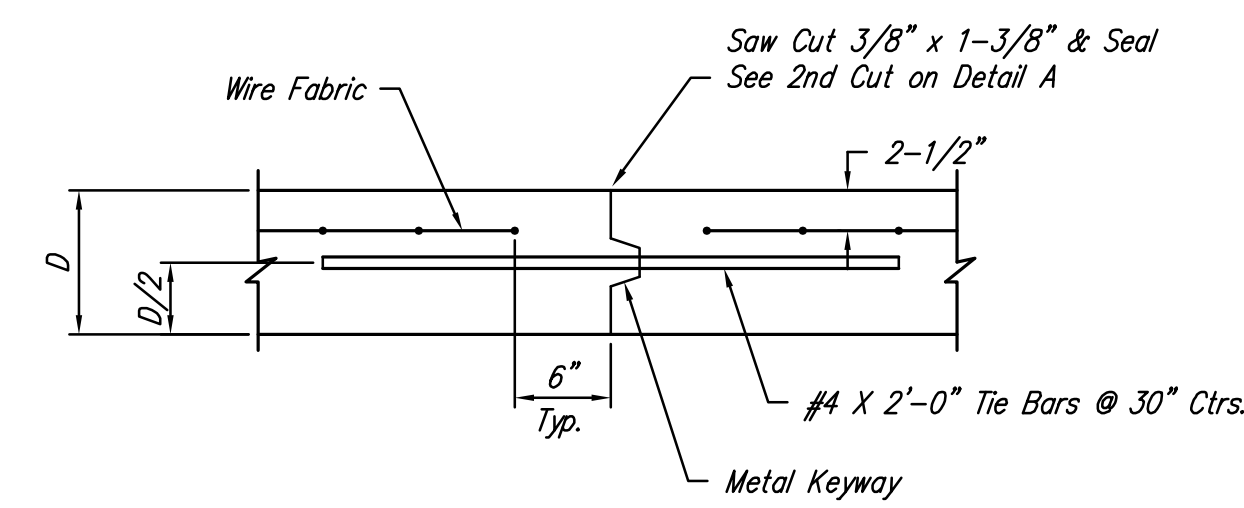

OPTIONAL CONTRACTION JOINT DETAIL (L.J.)

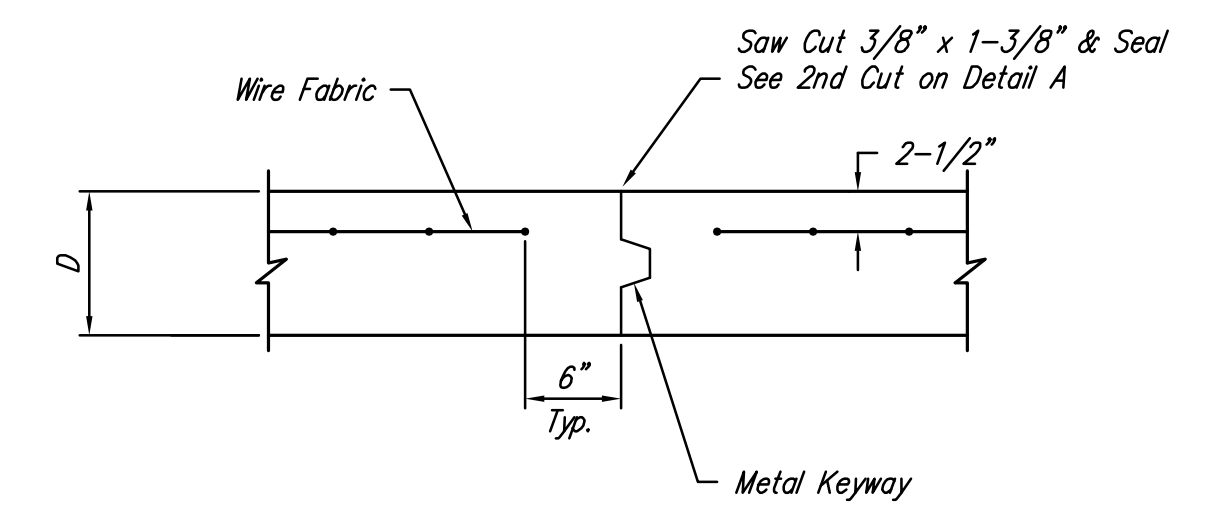

OPTIONAL LONGITUDINAL JOINT DETAIL (L.J.)

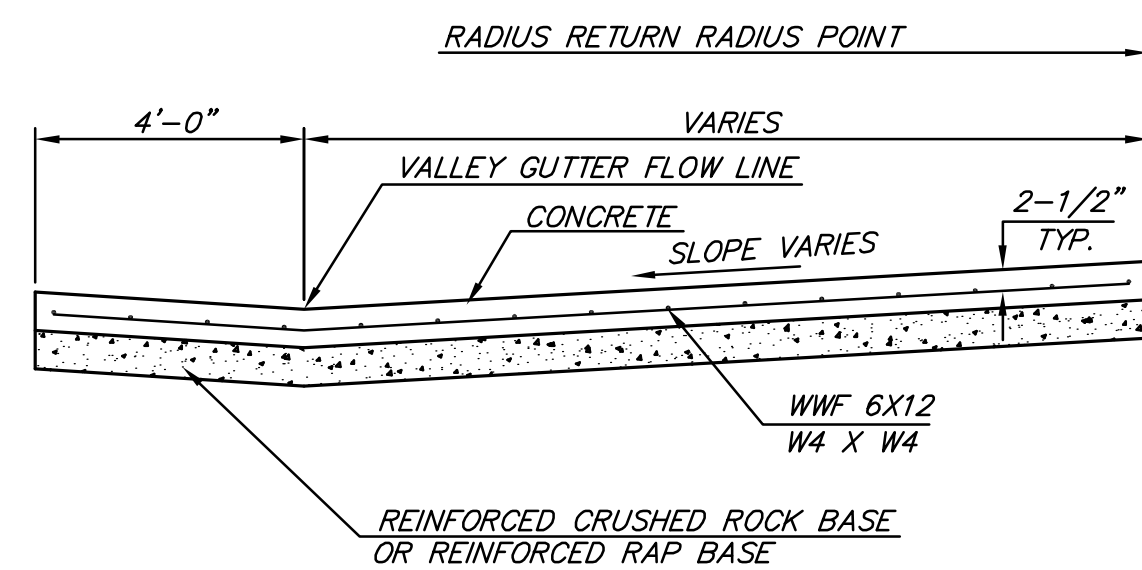

SECTION A-A

REINFORCED VALLEY GUTTER DETAIL

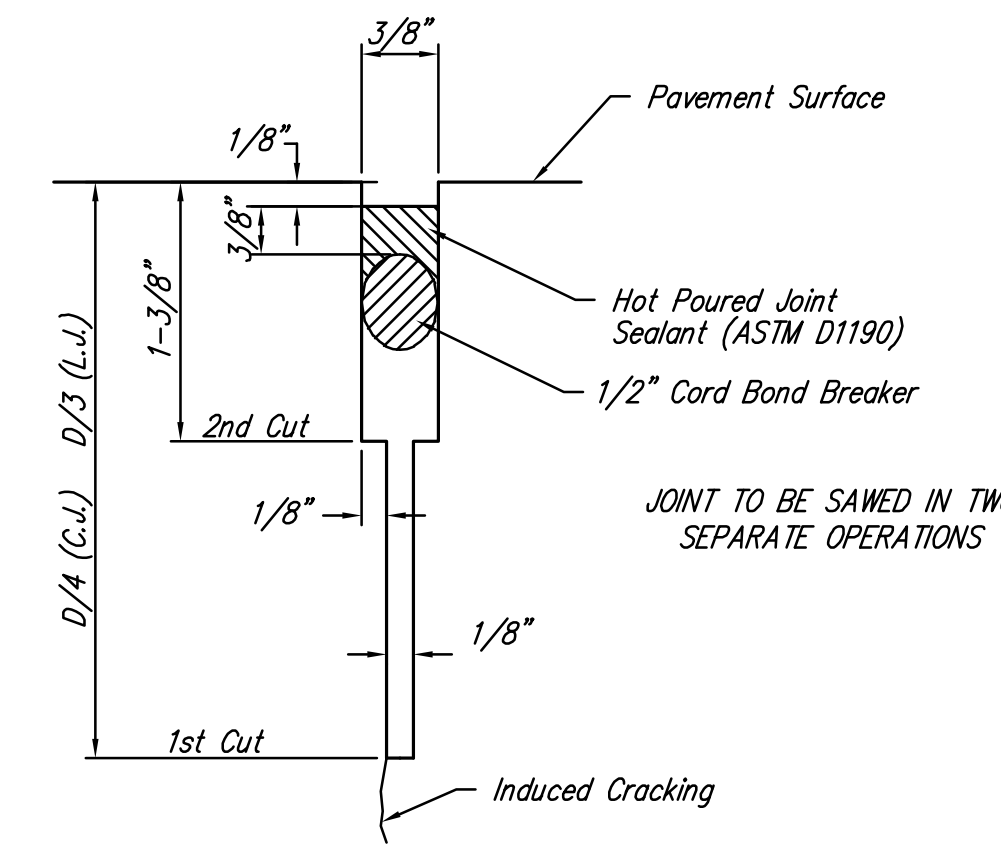

SAW JOINT DETAIL

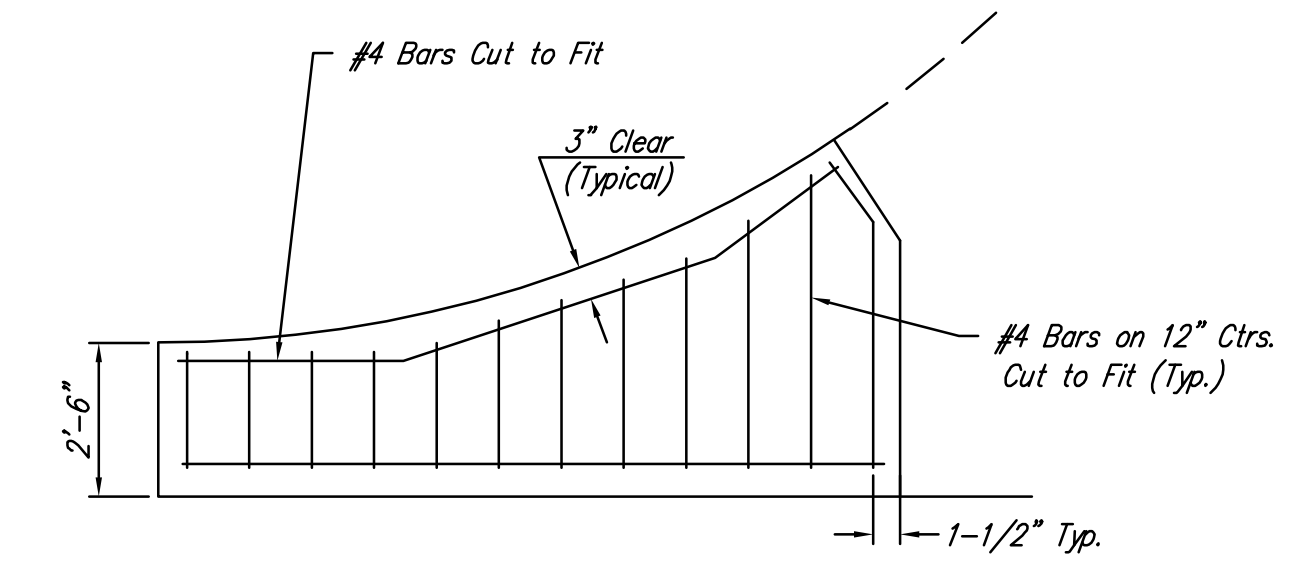

WING REINFORCING DETAIL

<p>CITY OF WICHITA PUBLIC WORKS ENGINEERING</p> <p>CITY ENGINEER'S OFFICE CITY HALL - SEVENTH FLOOR 455 NORTH MAIN STREET WICHITA, KANSAS 67202-1620 (316) 268-4501 (316) 268-4114 FAX</p>	VALLEY GUTTER DETAILS	
	JAMES L. ARMOUR, P.E. - CITY ENGINEER	
	PROJECT NUMBER 472-84613	OCA NUMBER 766229
	DATE Aug 09	Sheet 3 of 27

J:\CIVIL\06201\07165\PAV\PHASE 2\PHASE2B\07165_ED2.DWG