

STATE	PROJECT NO.	YEAR	SHEET NO.	TOTAL SHEETS
KANSAS	87N-0238-01	2009	21	59

SPECIAL NOTES

EXISTING PAVEMENT SHALL BE REMOVED BY THE PAVING CONTRACTOR. PAVEMENT IMMEDIATELY ADJACENT TO AND WITHIN THREE (3) FEET OF THE CROSSING SHALL BE REMOVED PRIOR TO THE INSTALLATION OF NEW RAILROAD CROSSING MATERIALS. PAVING CONTRACTOR SHALL COORDINATE THE PAVEMENT REMOVAL AT EACH CROSSING LOCATION WITH THE INVOLVED RAILROAD COMPANY. ALL EXPOSED JOINTS BETWEEN NEW CONSTRUCTION AND EXISTING PAVEMENT, WALK OR DRIVES SHALL BE TO NEAT LINES FORMED EITHER BY FULL DEPTH SAW CUT OR EXISTING JOINT.

LENGTHS OF CONCRETE OR RUBBER CROSSING MATERIAL SHOWN ON THE PLANS IN MOST CASES ARE TO EXTEND APPROX. THREE (3) FEET BEYOND BOTH SIDES OF THE PAVED MAIN TRAFFICWAY FOR EACH LOCATION. CONCRETE, RUBBER OR WOOD PLANKING MAY BE INSTALLED BY THE INVOLVED RAILROAD COMPANY FOR SIDEWALK, DRIVEWAY AND SHOULDER CROSSINGS WHERE REQUIRED. THE INVOLVED RAILROAD COMPANIES SHALL ADJUST THEIR RAILS TO ELEVATIONS AS SHOWN ON THE PLANS FOR EACH CROSSING LOCATION. VARIATIONS FROM THE TOP OF RAIL ELEVATIONS SHOWN WILL BE PERMITTED ONLY WHEN APPROVED BY THE FIELD ENGINEER FOR ANTICIPATED TRACK SETTLEMENT.

SURFACE OF NEW PAVEMENT AND CROSSING MATERIAL SHALL BE SET TO IDENTICAL ELEVATIONS AT THEIR JOINT OF JUNCTURE ONLY WHEN THE RAILROAD COMPANY USES APPROVED MECHANICAL EQUIPMENT TO COMPACT RAILROAD FILL AND BALLAST SUCH TO PRECLUDE TRACK SETTLEMENT. RAILROAD TRACK AND CROSSING MATERIAL ELEVATIONS OR PAVEMENT ELEVATIONS SHALL BE ADJUSTED IN A RANGE OF ONE-FOURTH (1/4) INCH TO ONE (1) TO ALLOW FOR TRACK SETTLEMENT WHEN THE RAILROAD COMPANY USES HAND METHODS FOR COMPACTION OF RAILROAD FILL AND BALLAST OR USE OF OTHER COMPACTION METHODS WHICH MAY NOT PRECLUDE TRACK SETTLEMENT. THE EXACT ELEVATION DIFFERENTIAL BETWEEN CROSSING MATERIAL AND PAVEMENT SHALL BE DETERMINED BY THE RAILROAD BASED ON THEIR EXPERIENCE FOR TRACK SETTLEMENT WITH CONCURRENCE BY THE ENGINEER.

INDIVIDUAL SECTIONS OF THE CROSSING MATERIAL SHALL BE OFFSET AT LEAST ONE TIE SPACE FROM EACH OTHER SUCH THAT THE ENDS OF THE CROSSING WILL MORE CLOSELY CONFORM TO SIDEWALK OR PAVEMENT CURB ALIGNMENTS WHERE RAILROAD CROSSINGS ARE SKEWED THIRTY (30) DEGREES OR MORE TO THE STREET.

DATE	
BY	
REFERENCES NOTED	
REFERENCES CHECKED	

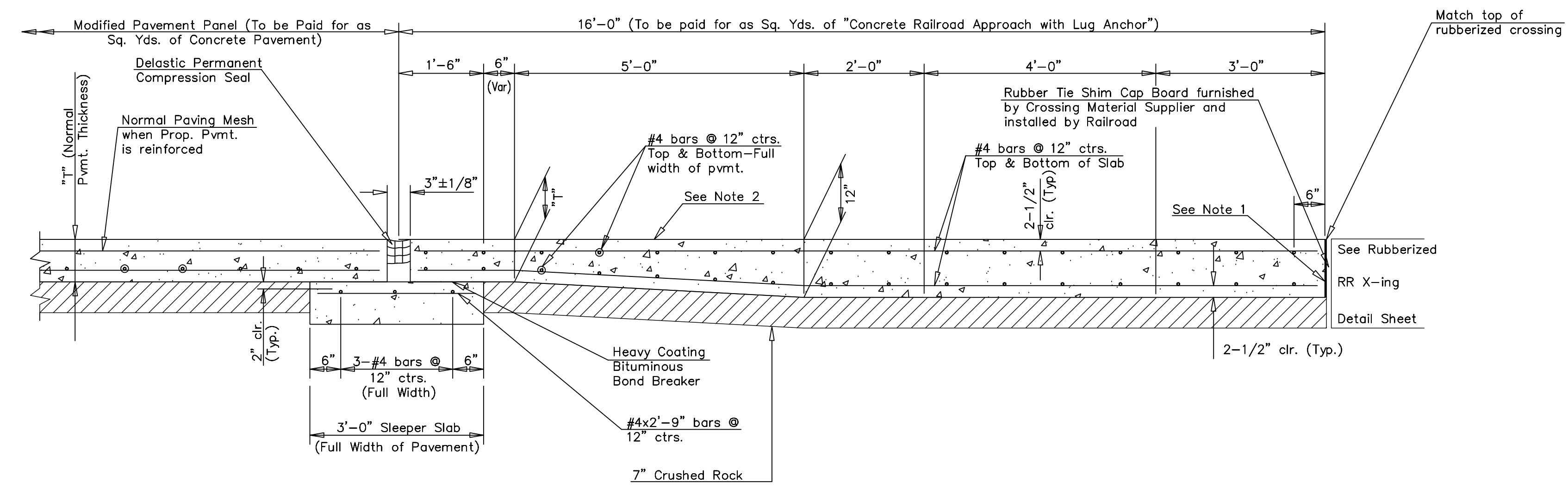
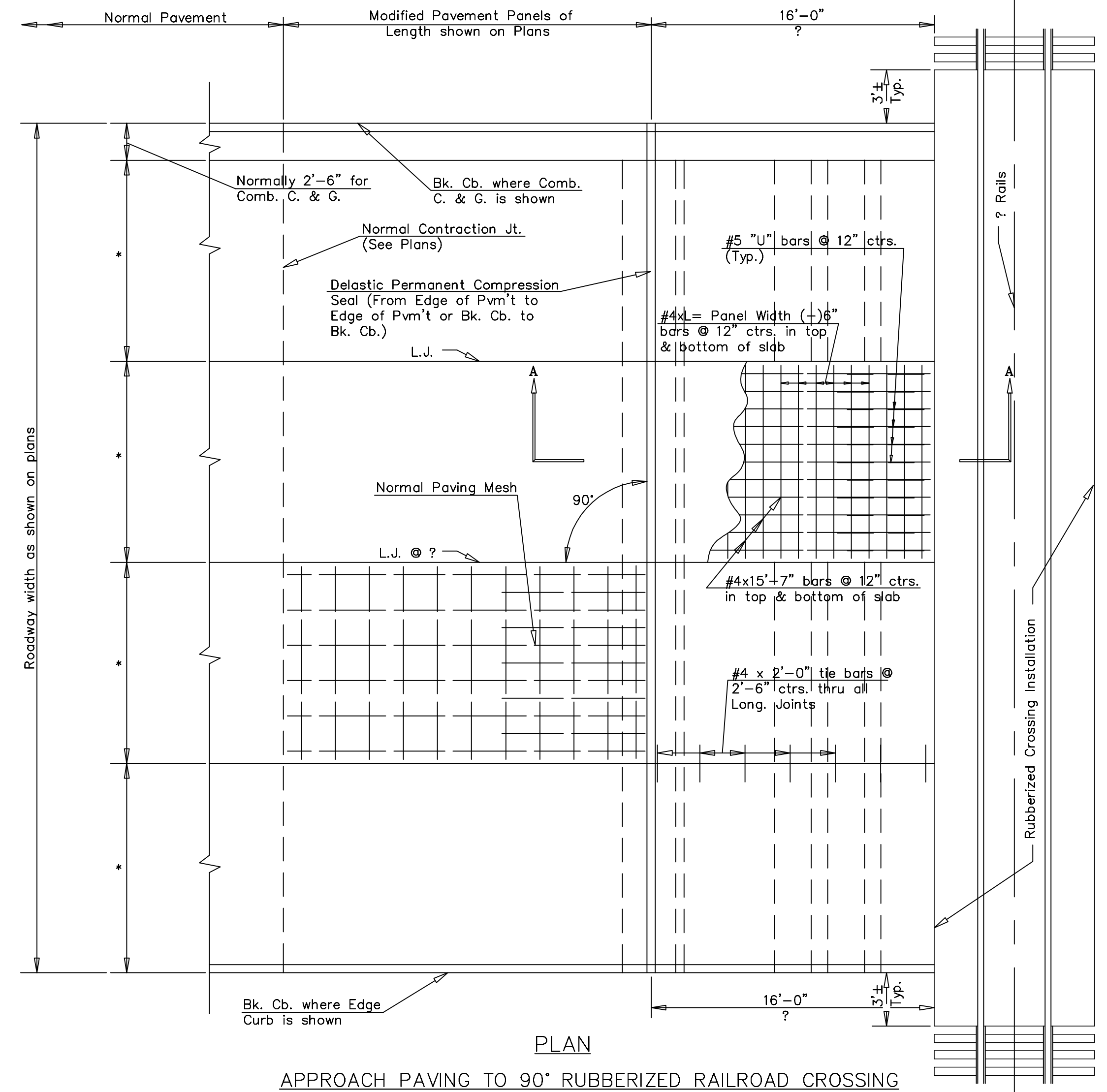
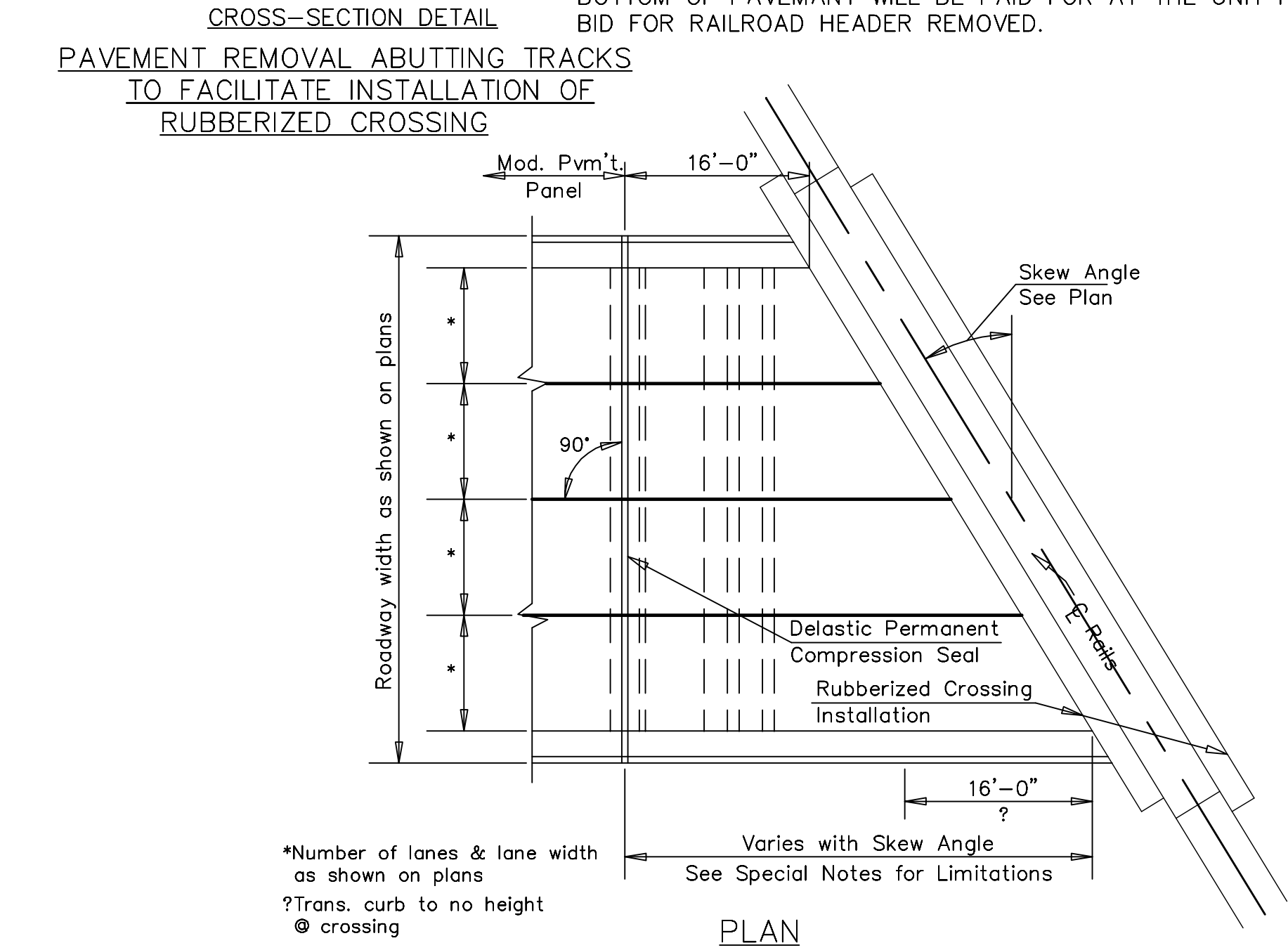
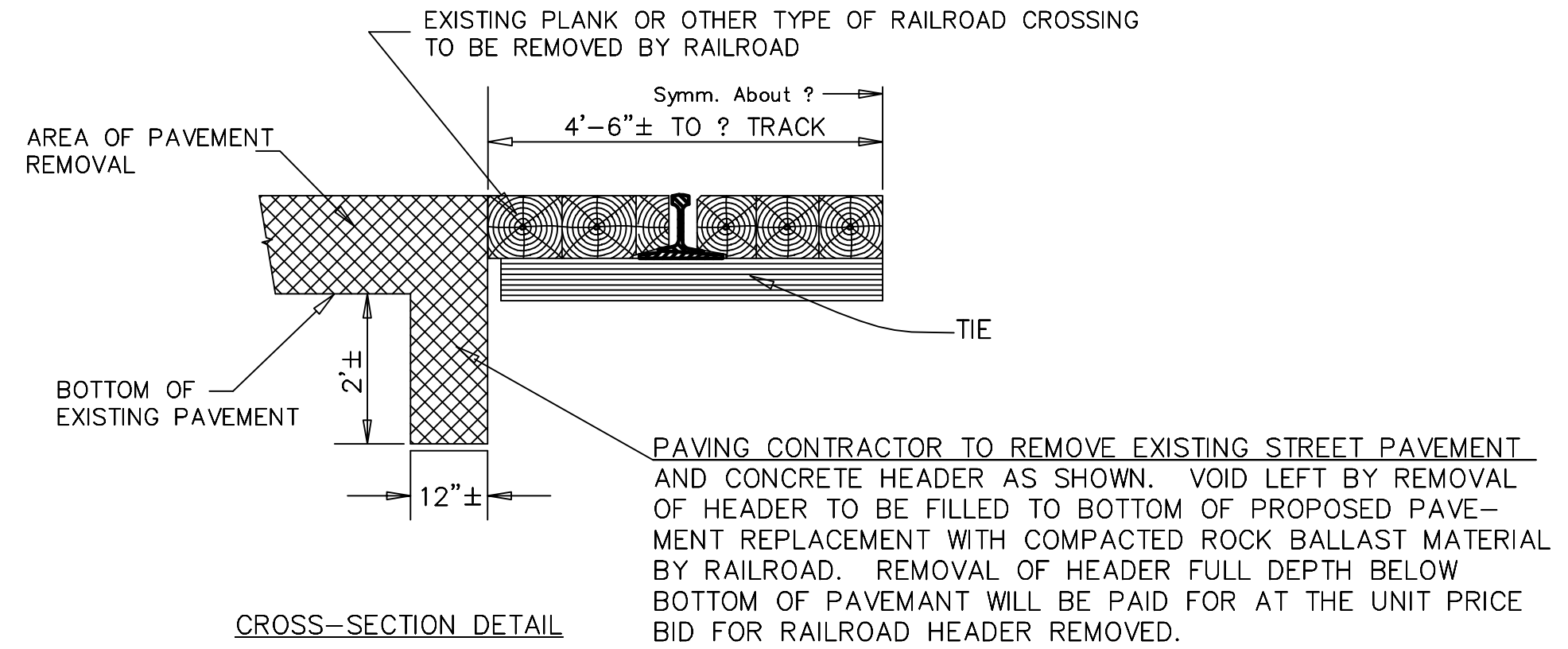

NOTE 1: One thickness of 90# tar paper for bond breaker on all mating surfaces between pavement, sidewalks, or drives and railroad crossing material; to be installed by Paving Contractor.

NOTE 2: Top of pavement true to X-slope and grade established by plan elevations and match of rubberized crossing installation (See special notes).

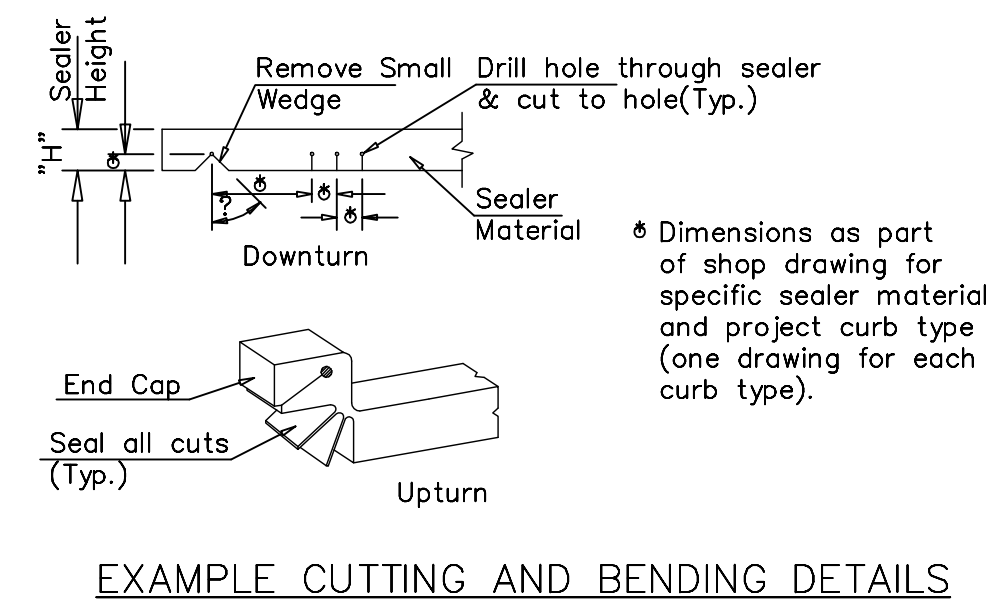

* Dimensions as part of shop drawing for specific sealer material and project curb type (one drawing for each curb type).

**RR X-INGS
FOR NEW CONCRETE
PAVEMENT**

JAMES L. ARMOUR, P.E., L.S.

OF