

EXPANSION JOINT

NOTE: Extra Thickness to be Subsidiary to Price of Square Yards Pavement

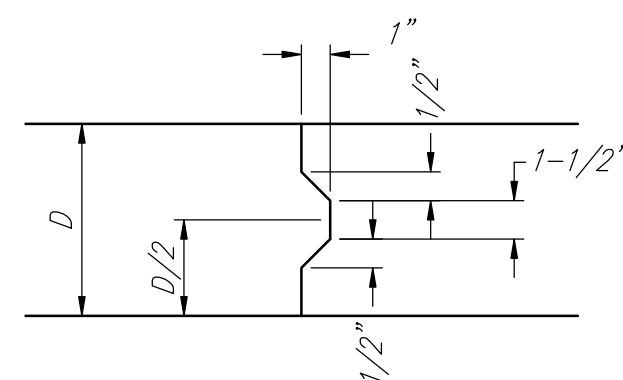

KEYWAY DETAIL

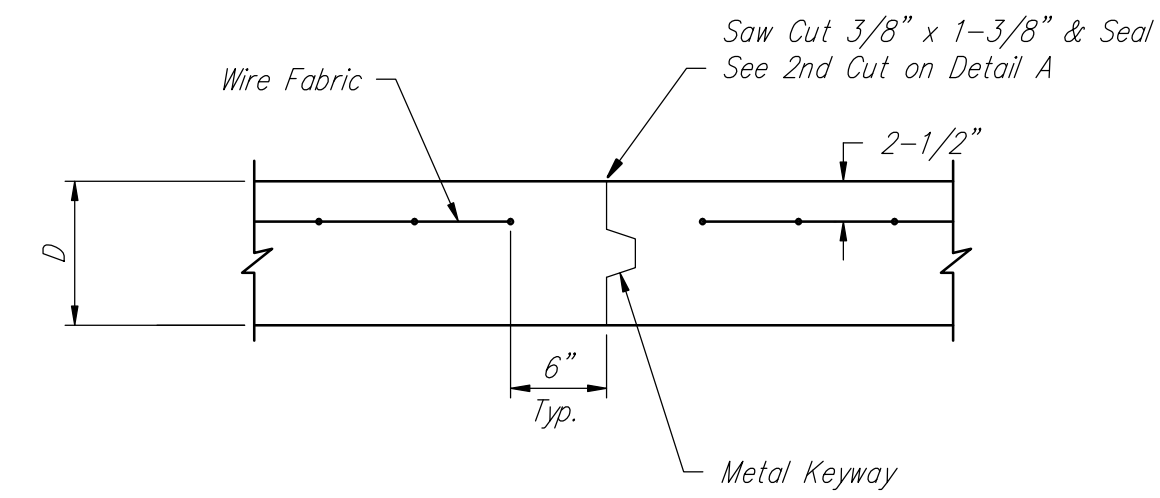

OPTIONAL CONTRACTION JOINT

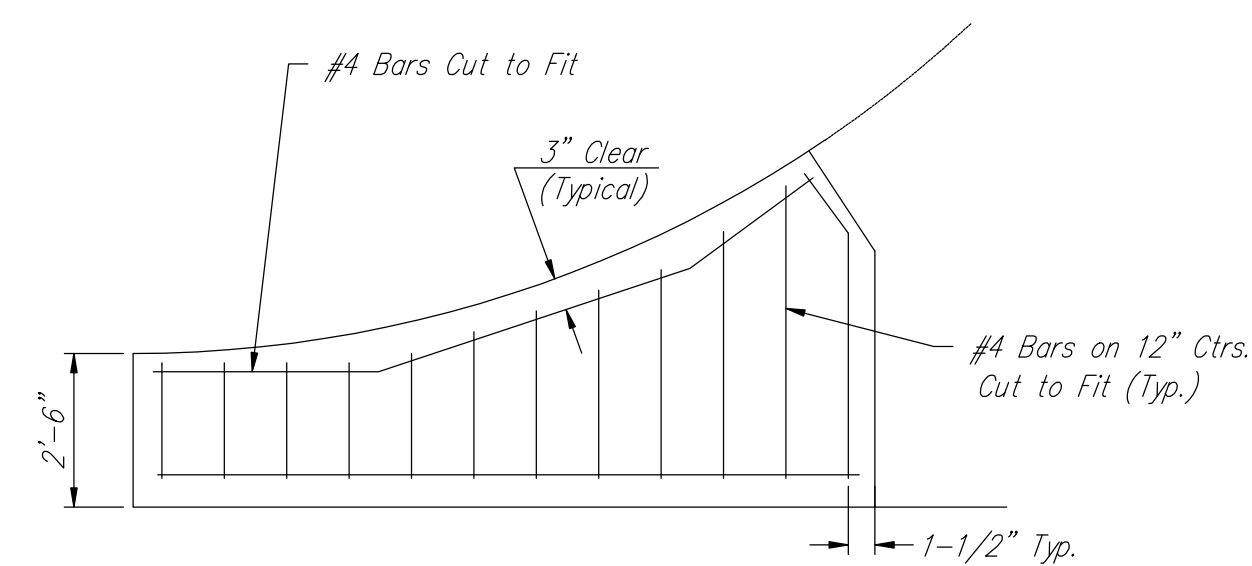

WING REINFORCING DETAIL

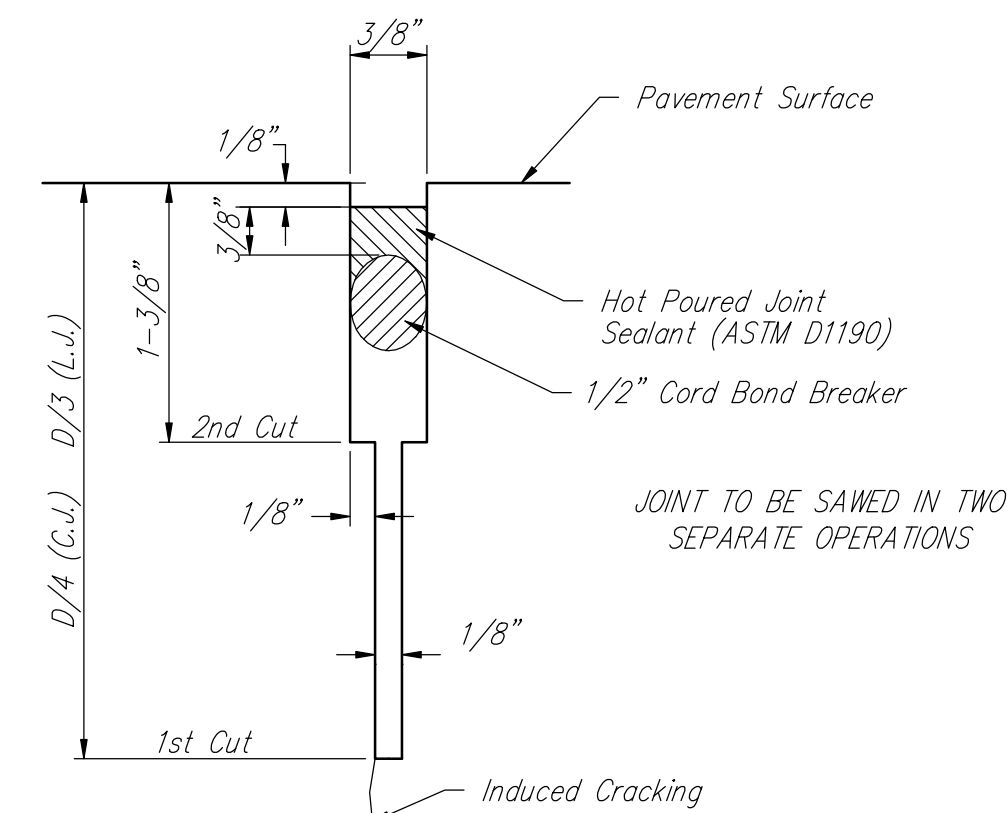

SAW JOINT DETAIL

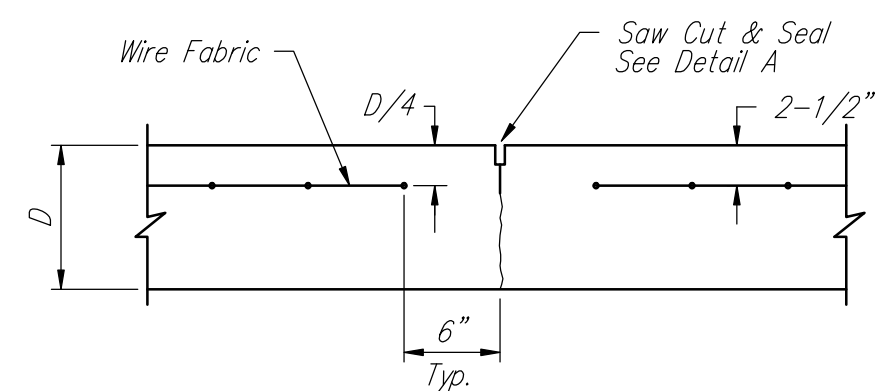

CONTRACTION JOINT DETAIL (C.J.)

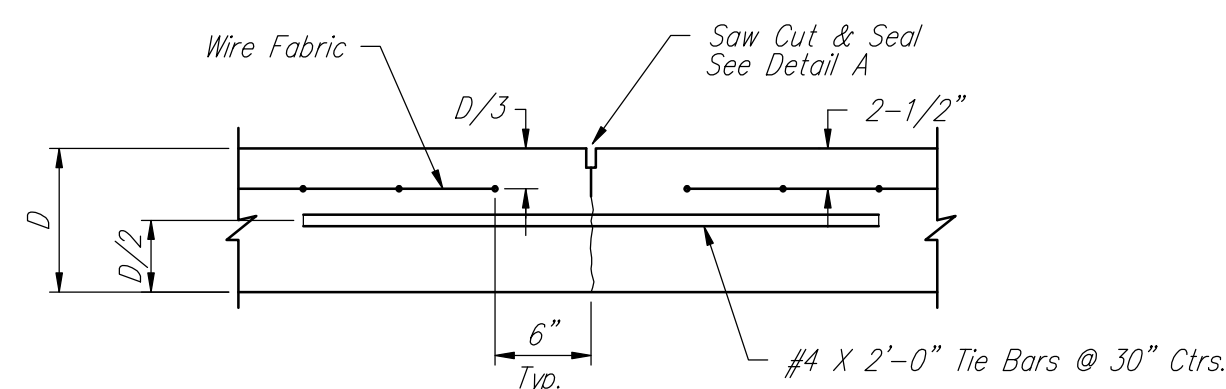

LONGITUDINAL JOINT DETAIL (L.J.)

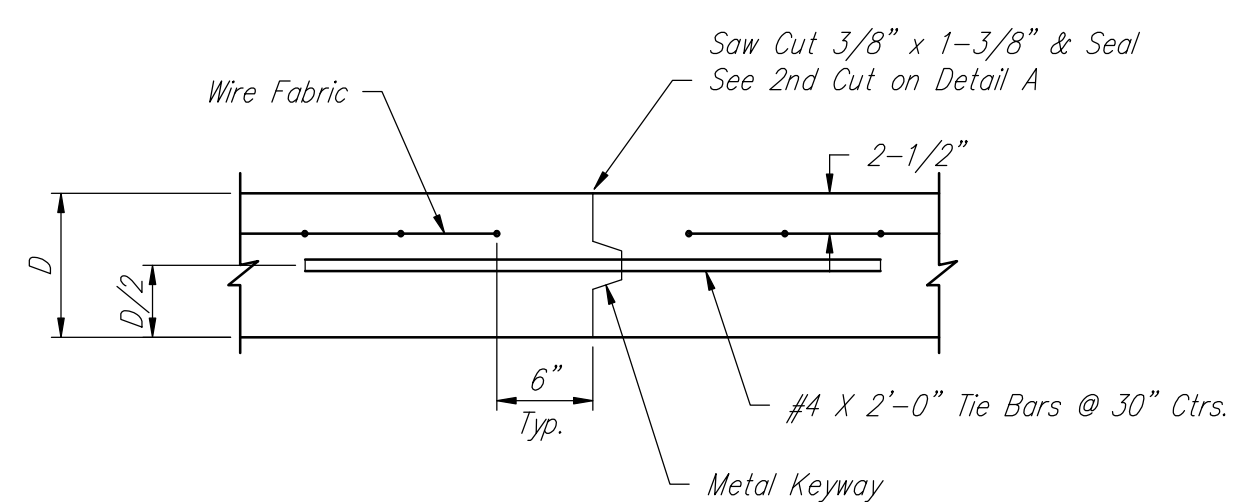

OPTIONAL LONGITUDINAL JOINT DETAIL (L.J.)

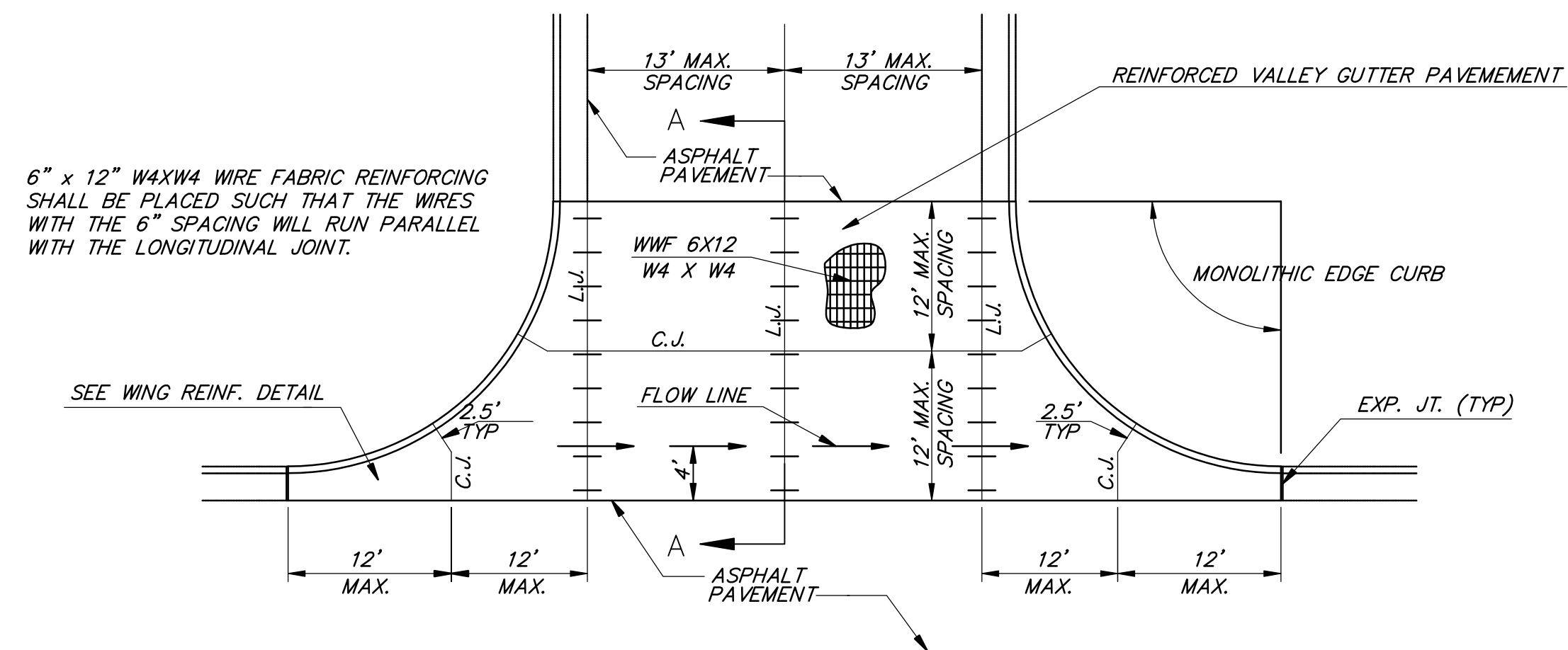

PLAN

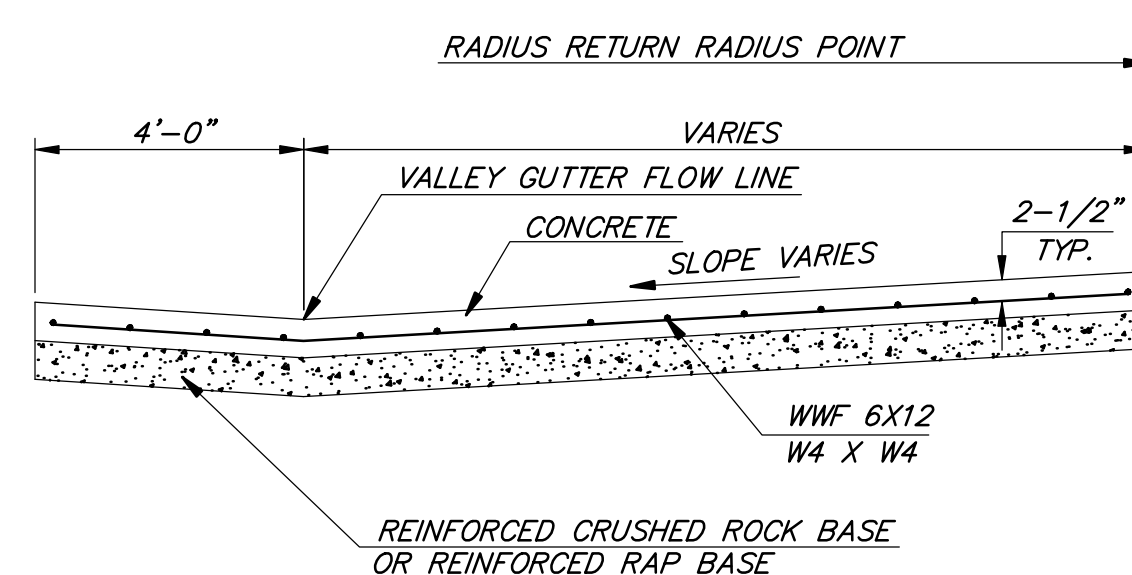

SECTION A-A

REINFORCED VALLEY GUTTER DETAIL

<p>THE CITY OF WICHITA</p>	VALLEY GUTTER DETAILS	
	<p>PROJECT NUMBER 472-84831</p>	<p>OCA # 766242</p>
<p>DATE MAR '96</p>	<p>SHEET 10 OF 10</p>	