

L1 BAR

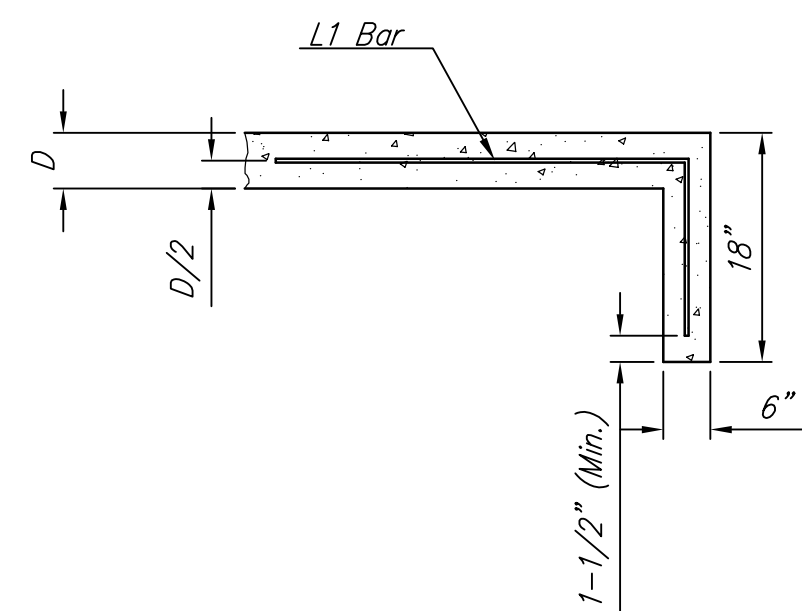

SECTION A-A
N.T.S.

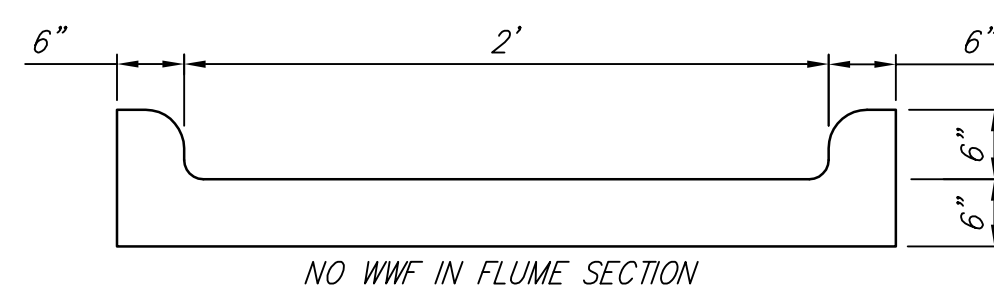

SECTION B-B
N.T.S.

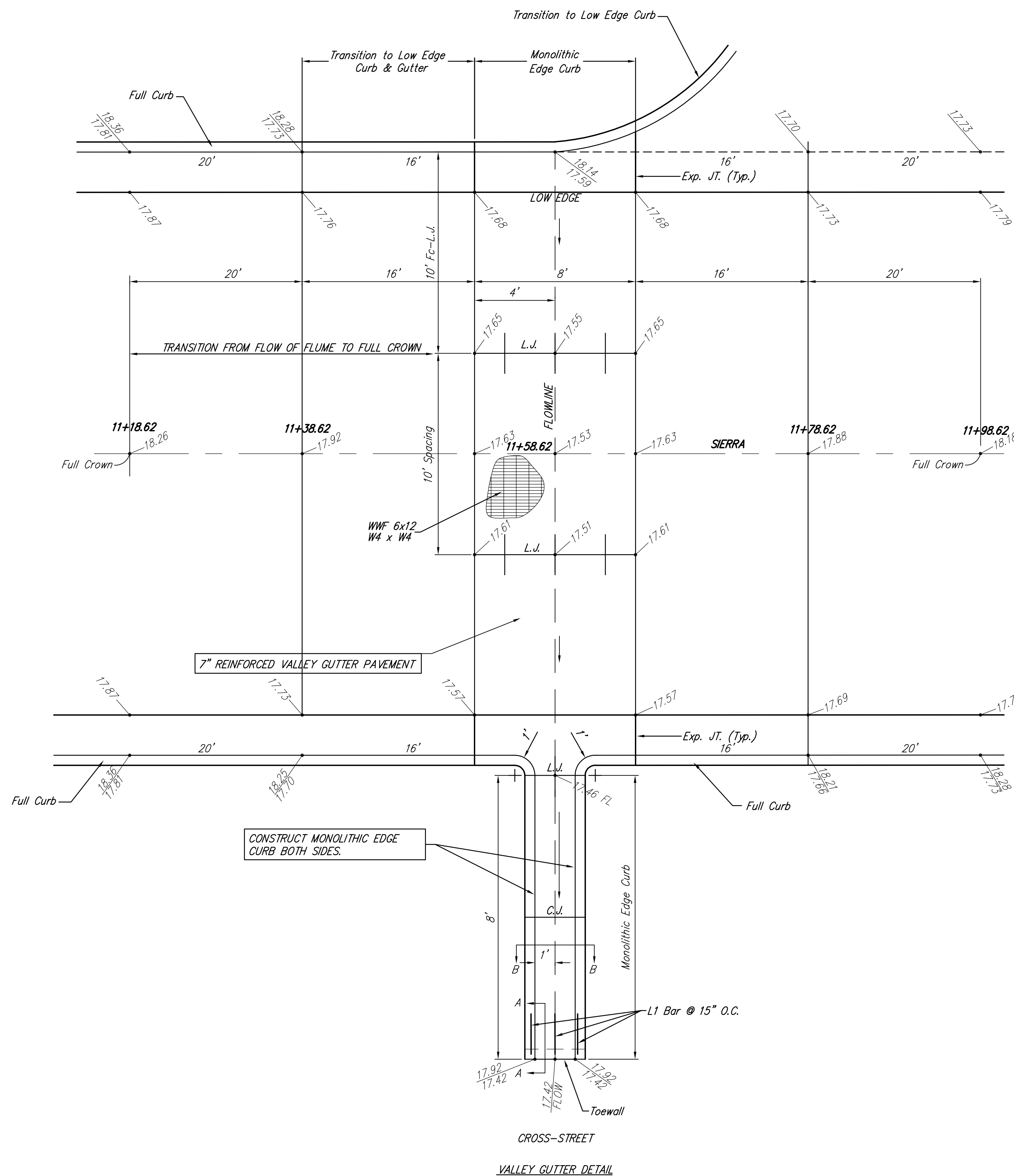

NOTE: Items on this sheet including: curb transitions, monolithic curb, concrete flume, joints, pavement transitions, valley gutter pavement, material, labor, and incidental costs) to be bid as Lump Sum subsidiary to "Cross Street Concrete Valley Gutter".

PUEBLO, MARIPOSA & SIERRA CROSS STREET VALLEY GUTTER DETAILS WICHITA, KANSAS			
	Ruggles & Bohm, P.A. Engineering, Surveying, Land Planning		
	924 North Main Wichita, Kansas 67203 www.rbkansas.com		
(316) 264-8008 (316) 264-4621 fax E-mail: info@rbkansas.com		DESIGN KWL DRAWN RLS REVIEW UTILITY DATE Sept 24, 2008	
DRAWING FILE <i>{VG Detail}</i>		PROJECT NUMBER 482-84648	
SHEET 18 OF 33			REVISION 3248T