

**EXPANSION JOINT**

NOTE: Extra Thickness to be Subsidiary to Price of Square Yards Pavement

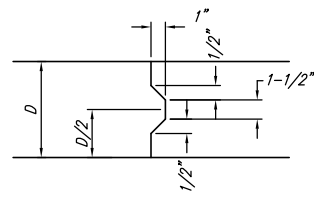

**KEYWAY DETAIL**

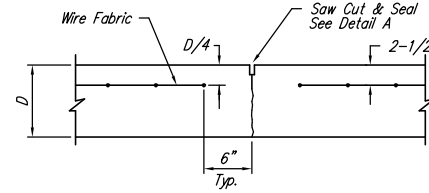

**CONTRACTION JOINT DETAIL (C.J.)**

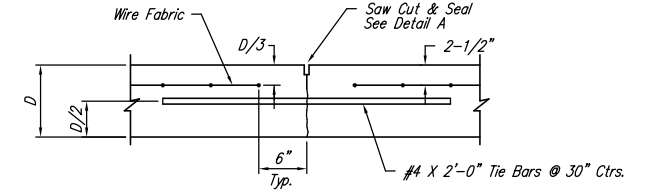

**LONGITUDINAL JOINT DETAIL (L.J.)**

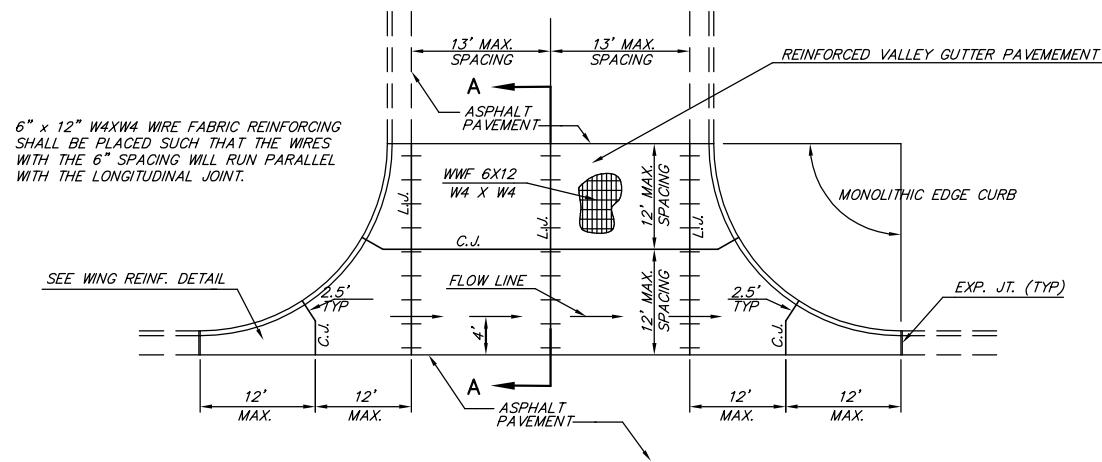

**PLAN**

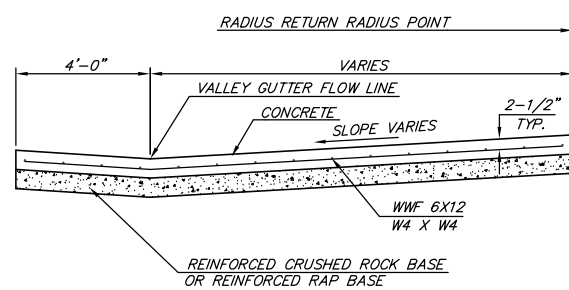

**SECTION A-A**

**REINFORCED VALLEY GUTTER DETAIL**

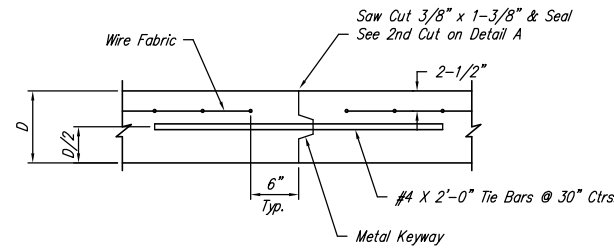

**OPTIONAL LONGITUDINAL JOINT DETAIL (L.J.)**

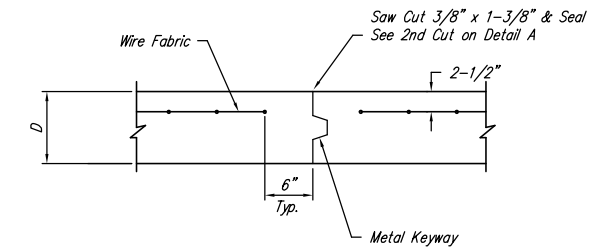

**OPTIONAL CONTRACTION JOINT**

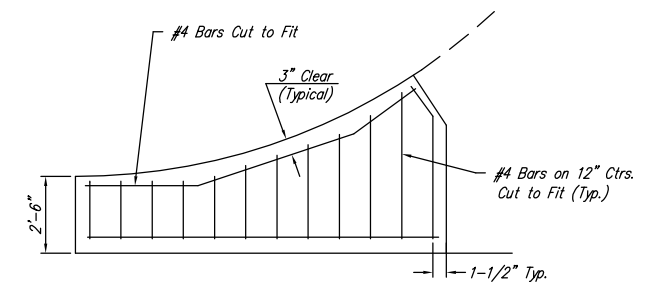

**WING REINFORCING DETAIL**

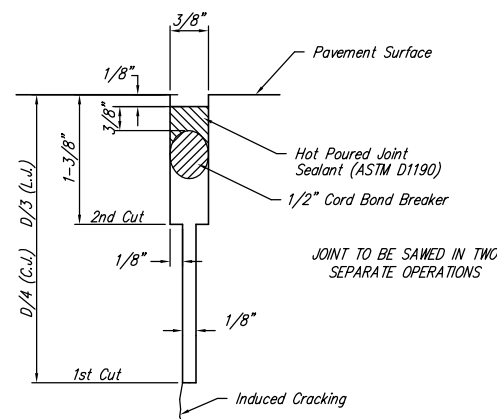

**SAW JOINT DETAIL**

<p>THE CITY OF WICHITA</p> <p>CITY ENGINEER'S OFFICE CITY HALL - SEVENTH FLOOR 455 NORTH MAIN STREET WICHITA, KANSAS 67202 (316) 268-4501 (316) 268-4114 FAX</p>	<b>VALLEY GUTTER DETAILS</b>	
	JAMES L. ARMOUR, P.E. - CITY ENGINEER	
PROJECT NUMBER	472-84084	OCA NUMBER
DATE	Jul 06	766101
		<b>Sheet 4 of 39</b>

H:\CIVIL\02167\DWG\PAV\3RD\_ADD\PHA\02167ED03.DWG