

SECTION A-A

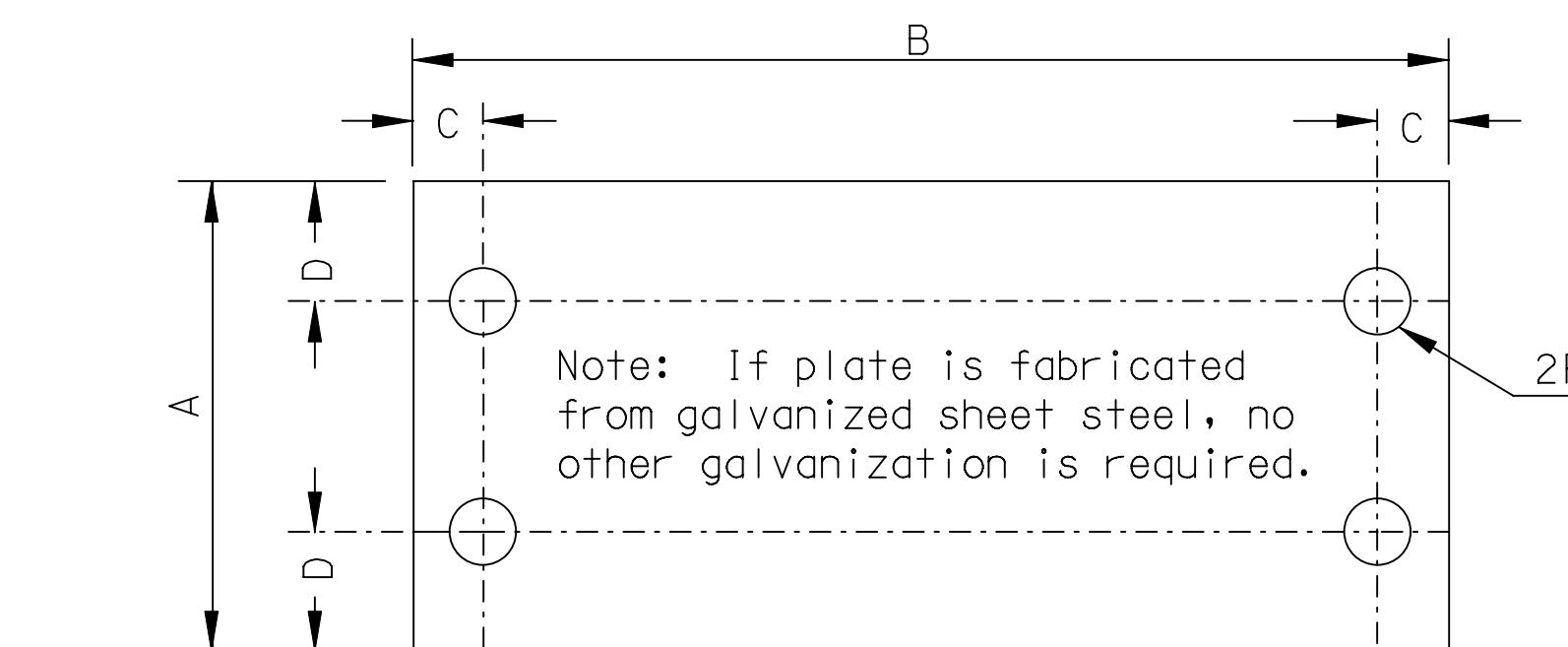

BOLT RETAINER PLATE DETAIL
30 gage sheet steel

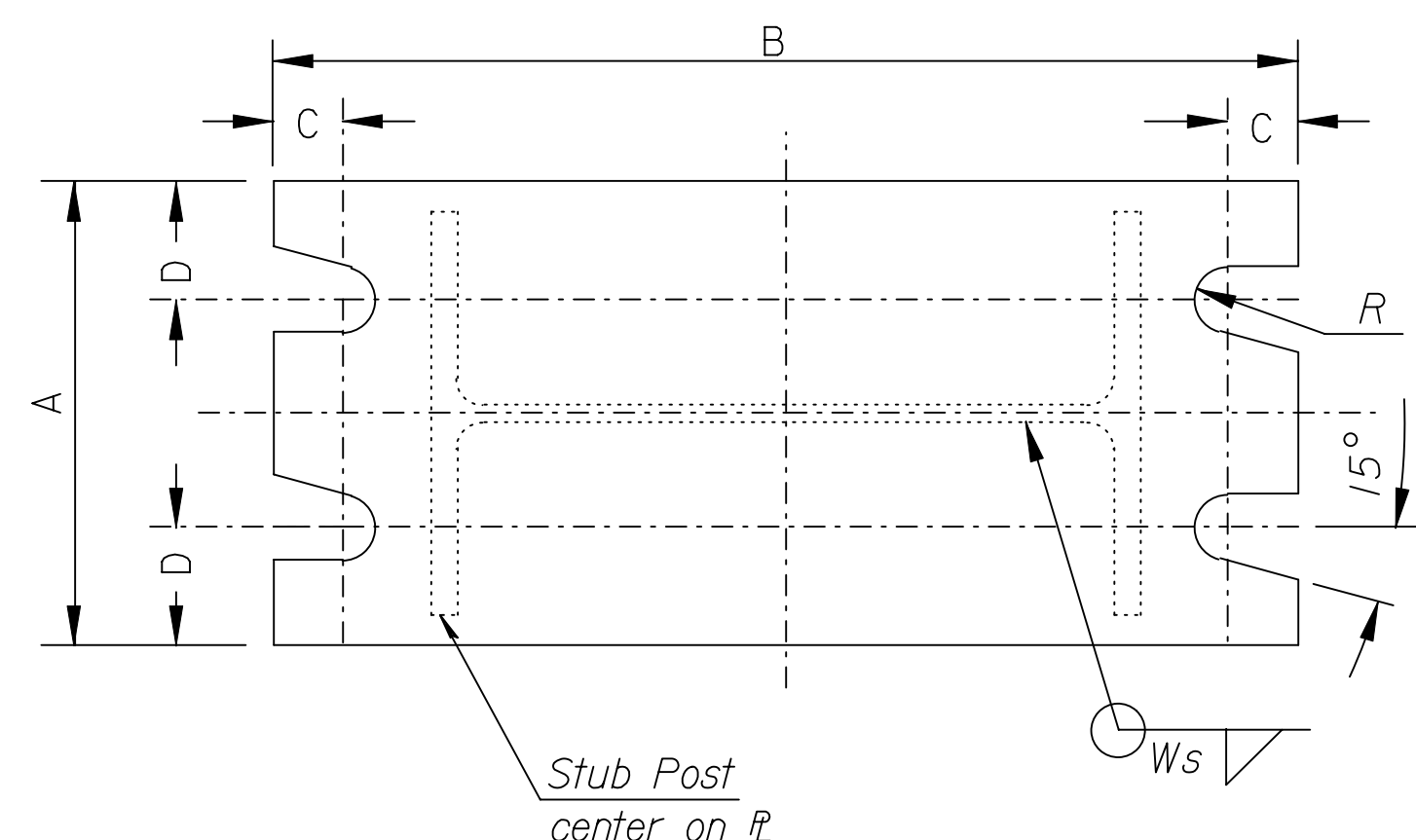

SECTION B-B

POST SIZE	BOLT SIZE	TORQUE (in. lbs.)	Ws	T1	T2	A	B	C	D	R
S 3 x 5.7	1/2" x 2 3/4"	140	1/4"	3/4"	5/8"	3"	6 1/2"	3/4"	3/4"	9 3/2"
W 6 x 9	5/8" x 3"	345	1/4"	7/8"	5/8"	4 5/8"	9 5/8"	3/4"	1 1/16"	1 1/32"
W 10 x 12	5/8" x 3 1/4"	345	1/4"	1"	3/4"	4 5/8"	1' 1 5/8"	3/4"	1 1/16"	1 1/32"
W 10 x 22	7/8" x 4"	640	3/8"	1 3/8"	1"	6 5/8"	1' 2 5/8"	7/8"	1 1/16"	1 5/32"

⊗ S 3 x 7.5 steel post may be substituted for the S 3 x 5.7 steel post

NOTE:

The sections shown are for right shoulder or gore installations. The plate slot bevels are to be reversed for left shoulder installations.

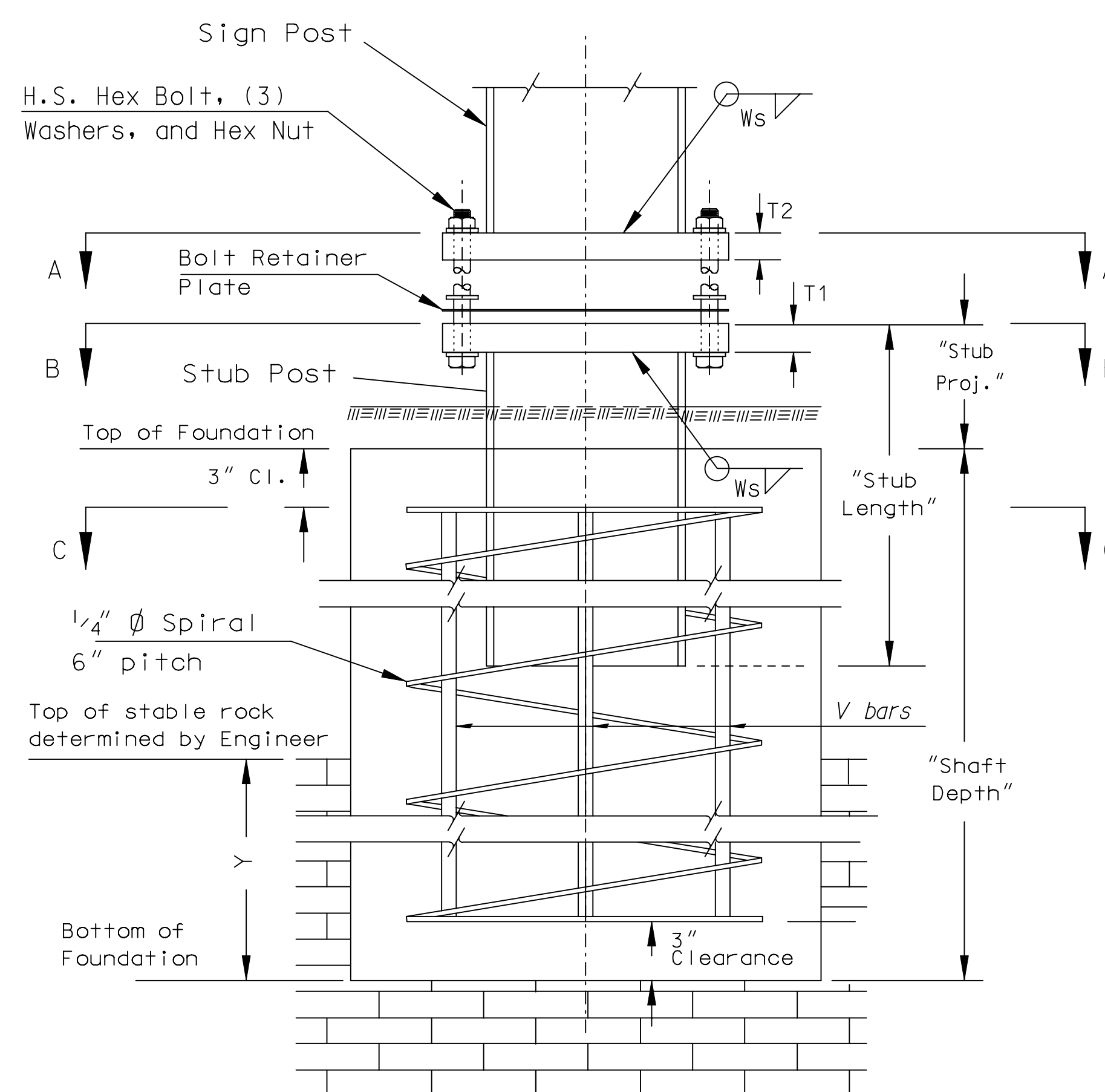

SIDE ELEVATION

POST SIZE	STUB LENGTH	STUB PROJ.	SHAFT DIA.	SHAFT DEPTH			V BAR	
				A572M ALT.	A36M	Y†	NO.	SIZE
S 3 x 5.7	1' 9"	6"	2' 0"	6' 0"	6' 0"	2' 6"	5	#4
W 6 x 9	2' 6"	6 1/4"	2' 0"	6' 0"	6' 0"	3' 6"	6	#4
W 10 x 12	2' 9"	6 1/4"	2' 0"	8' 0"	8' 0"	4' 0"	5	#6
W 10 x 22	3' 3"	7"	2' 6"	12' 0"	11' 0"	5' 6"	13	#6

† When rock is encountered, while drilling the shaft for the concrete foundation, extend the shaft into the rock the distance "Y". The total shaft depth shall not exceed that given for the corresponding post size and steel type.

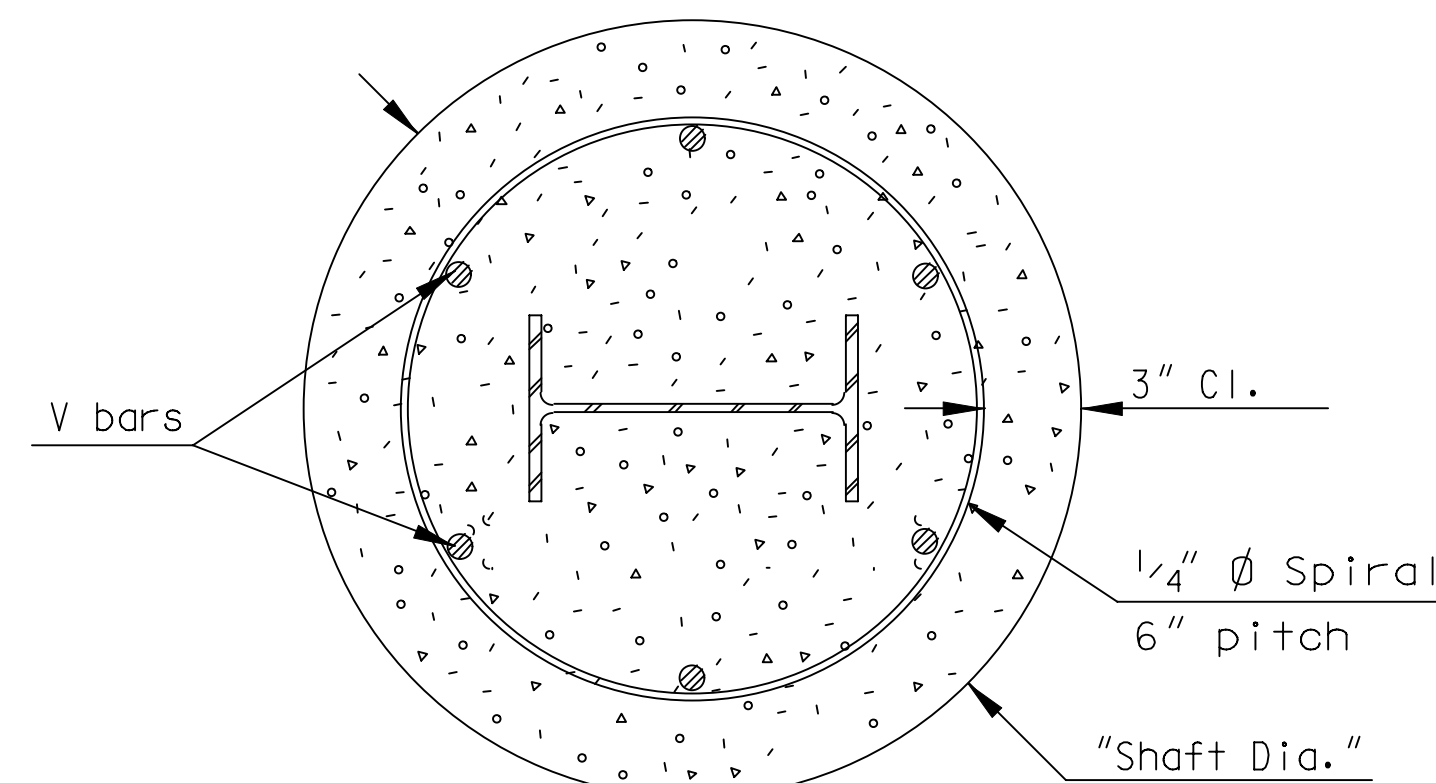

SECTION C-C

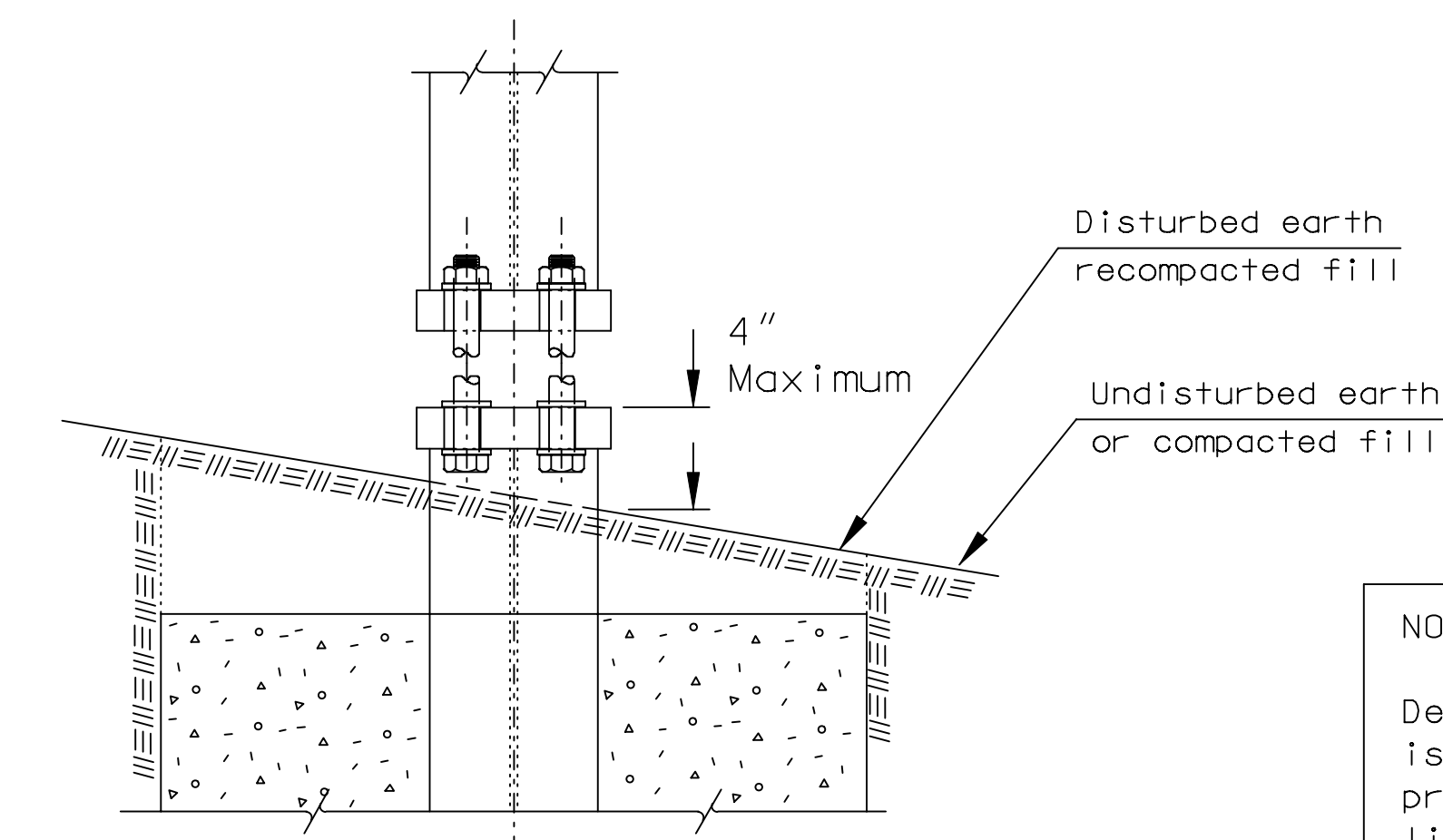

FRONT ELEVATION

NOTE TO THE ENGINEER:
The intent of the "Roadside Design Guide" and these plans is to have a 4" or less projection above the ground line after impact.

GENERAL NOTES

Design conforms with AASHTO "Standard Specifications for Structural Supports for Highway Signs, Luminaires, and Traffic Signals 2002". Breakaway base and hinge design conforms with "Breakaway Roadside Sign Support Structures" Texas Transportation Institute, Texas A&M University, July 1967.

Foundation design conforms with "Design Procedure Compared to Full-Scale Tests of Drilled Shaft Footings", Texas Transportation Institute, Feb. 1970.

All structural steel shall conform to ASTM A36 or A572 Grade 345. Alternates using ASTM A588 or A242 Grade 345 or other approved steels may be substituted for ASTM 572 steel. All structural steel shall be galvanized in accordance with ASTM A123 after fabrication.

All high strength bolts, nuts, and washers shall conform to ASTM A325 and shall be coated in accordance with the coating specifications.

PROCEDURE FOR ASSEMBLY OF BASE CONNECTION:

- Assemble post to stub with bolts; with bolt retainer plate and one flat washer (on each bolt) between base plates.
- Plumb post by varying thickness of washers between base plates.
- Tighten all bolts the maximum possible with a 12 to 15 inch wrench to bed washers and shim and to clean bolt threads. Then loosen each bolt in turn and retighten in a systematic order to the prescribed torque (see table). DO NOT OVER TIGHTEN.
- Burr threads at junction with nut using a center punch to prevent nut loosening.

All dimensions are in inches, unless otherwise noted.

3				
2				
1				
NO.	DATE	REVISIONS	BY	APP'D

KANSAS DEPARTMENT OF TRANSPORTATION
DETAILS FOR
STEEL BEAM BREAKAWAY POSTS
(SHEET 1 of 2)

TE463	07-01-03
FHWA APPROVAL 07-22-2003	APP'D Steven A. Buckley
DESIGNED DDG	DETAILED AAD
DESIGN CK. SAB	DETAIL CK. DDG
QUANTITIES	TRACED
QUAN. CK.	TRACE CK.