

BANDED SIGN MOUNTING BRACKET DETAIL

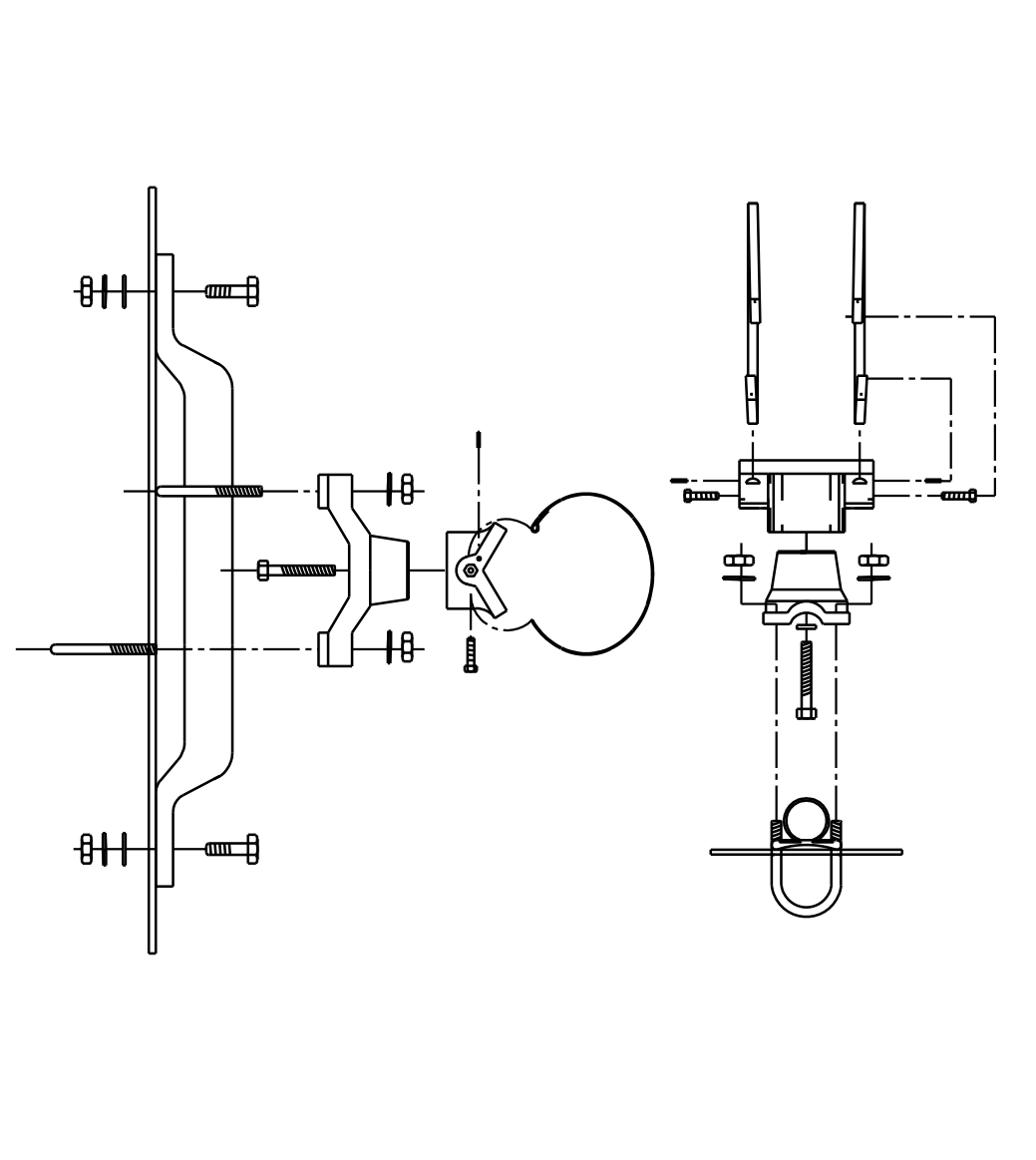

TYPE I SIGNAL MOUNTING BRACKET ASSEMBLY DETAIL

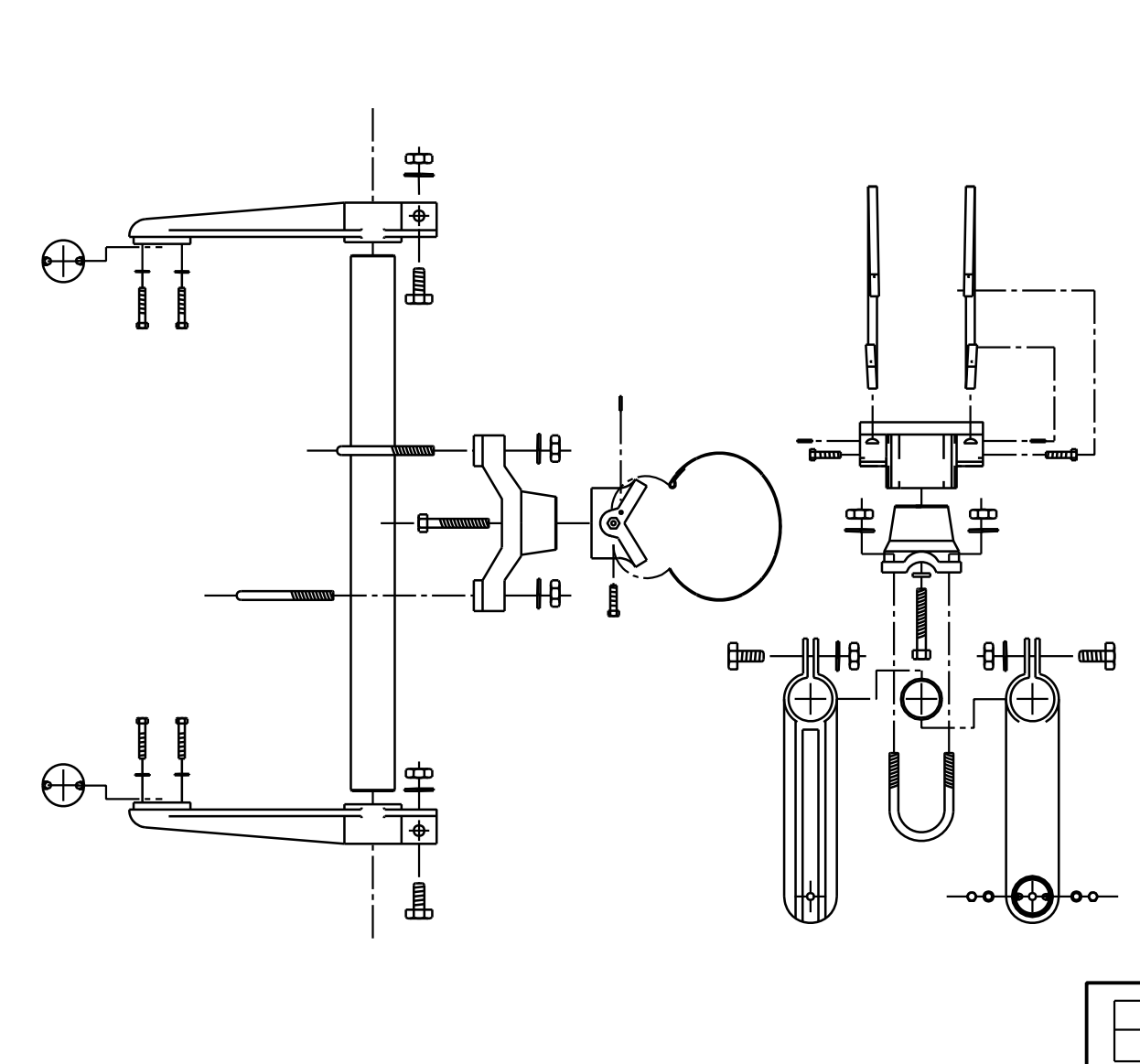

STANDARD SIGNING

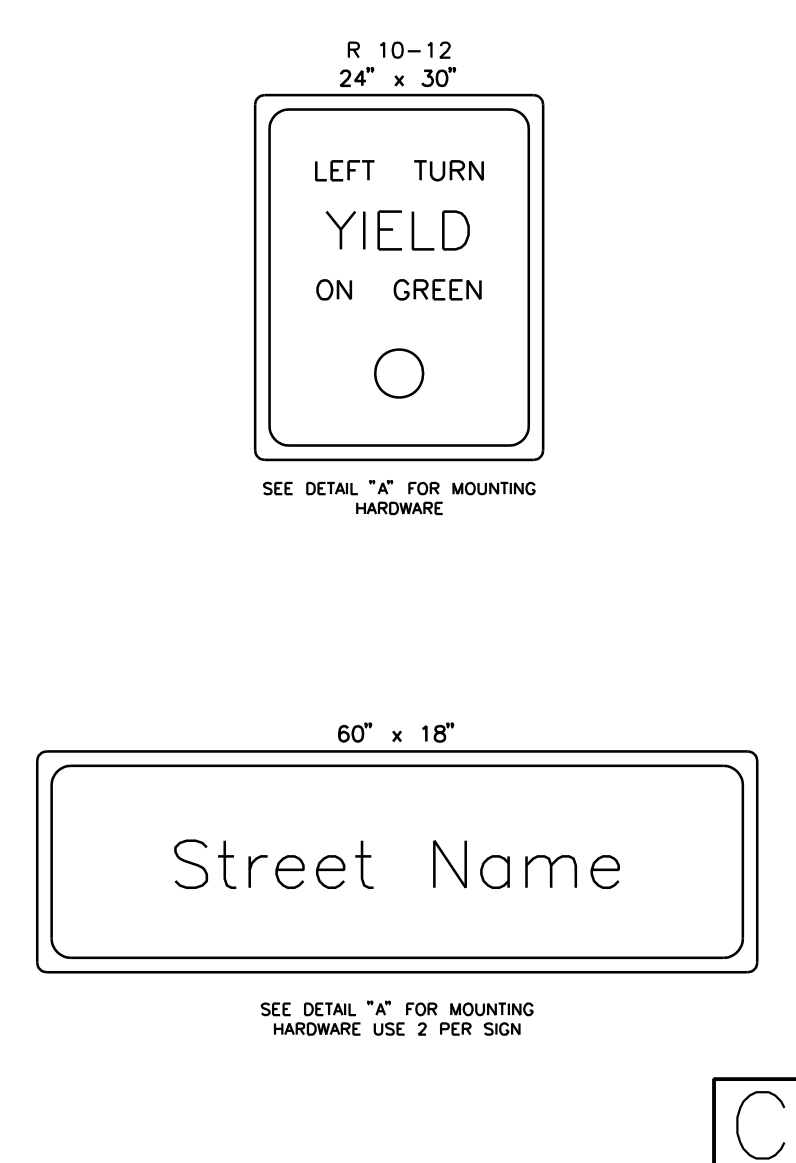

TYPE III SIDE-OF-POLE MOUNTING BRACKET ASSEMBLY

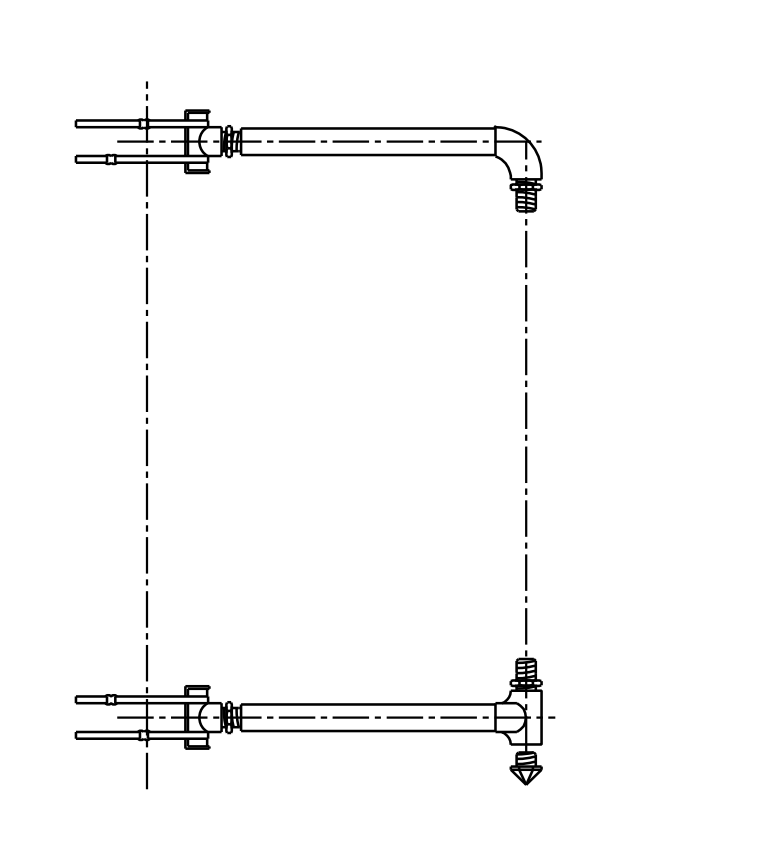

TYPE II SIGNAL MOUNTING BRACKET ASSEMBLY (SIDE-OF-POLE)

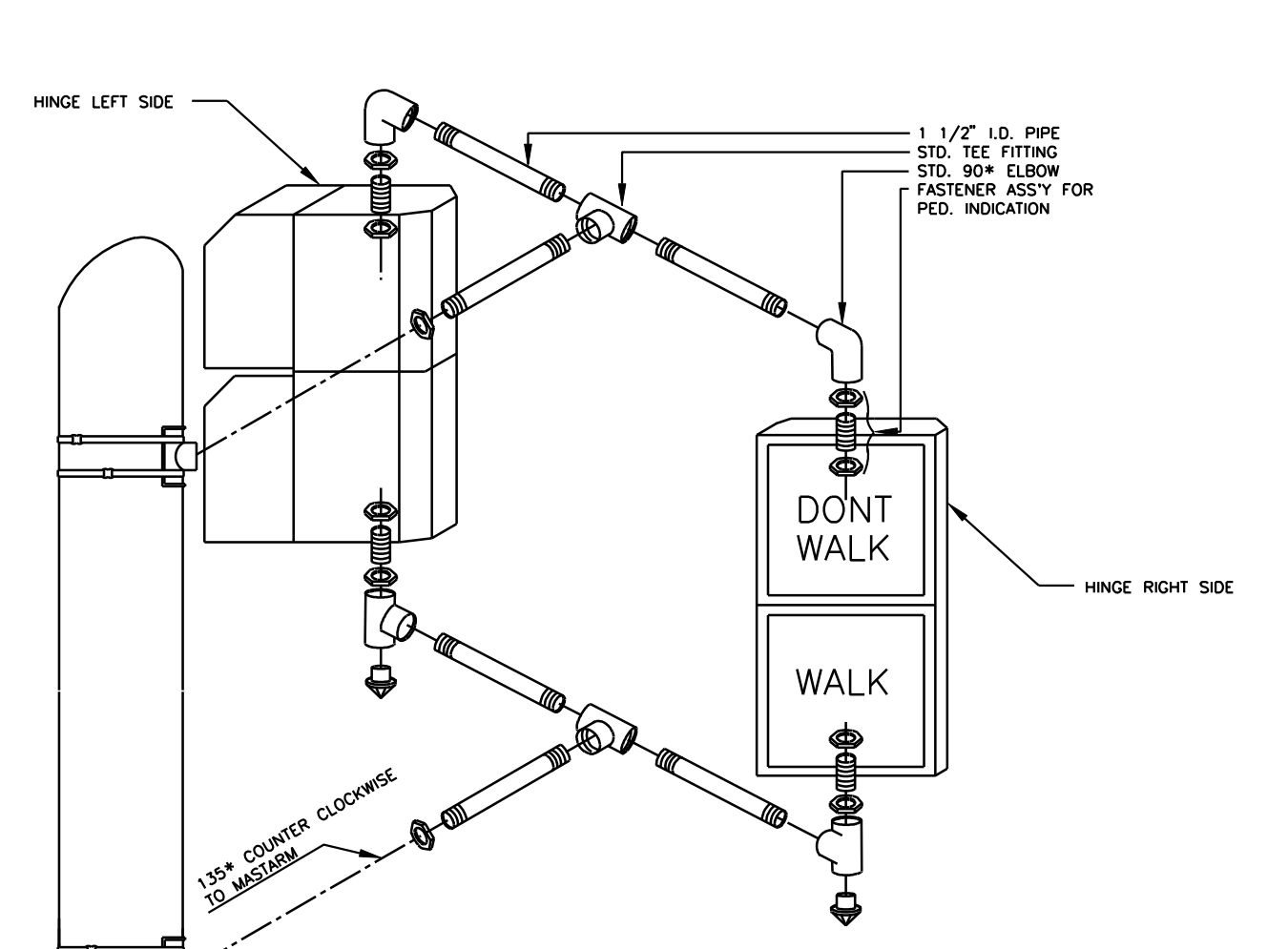

1. DIRECTIONAL ALIGNMENT OF PED. INDICATIONS & BRACKET(S) SHALL BE DETERMINED IN THE FIELD BY THE ENGINEER.
2. THROUGH HOLES IN THE POLE SHALL BE DRILLED AND WELL REAMED TO PREVENT CABLE CHAFING.
3. HINGE PEDESTRIAN SIGNAL DOORS AWAY FROM POLE.

REBAR CAGE

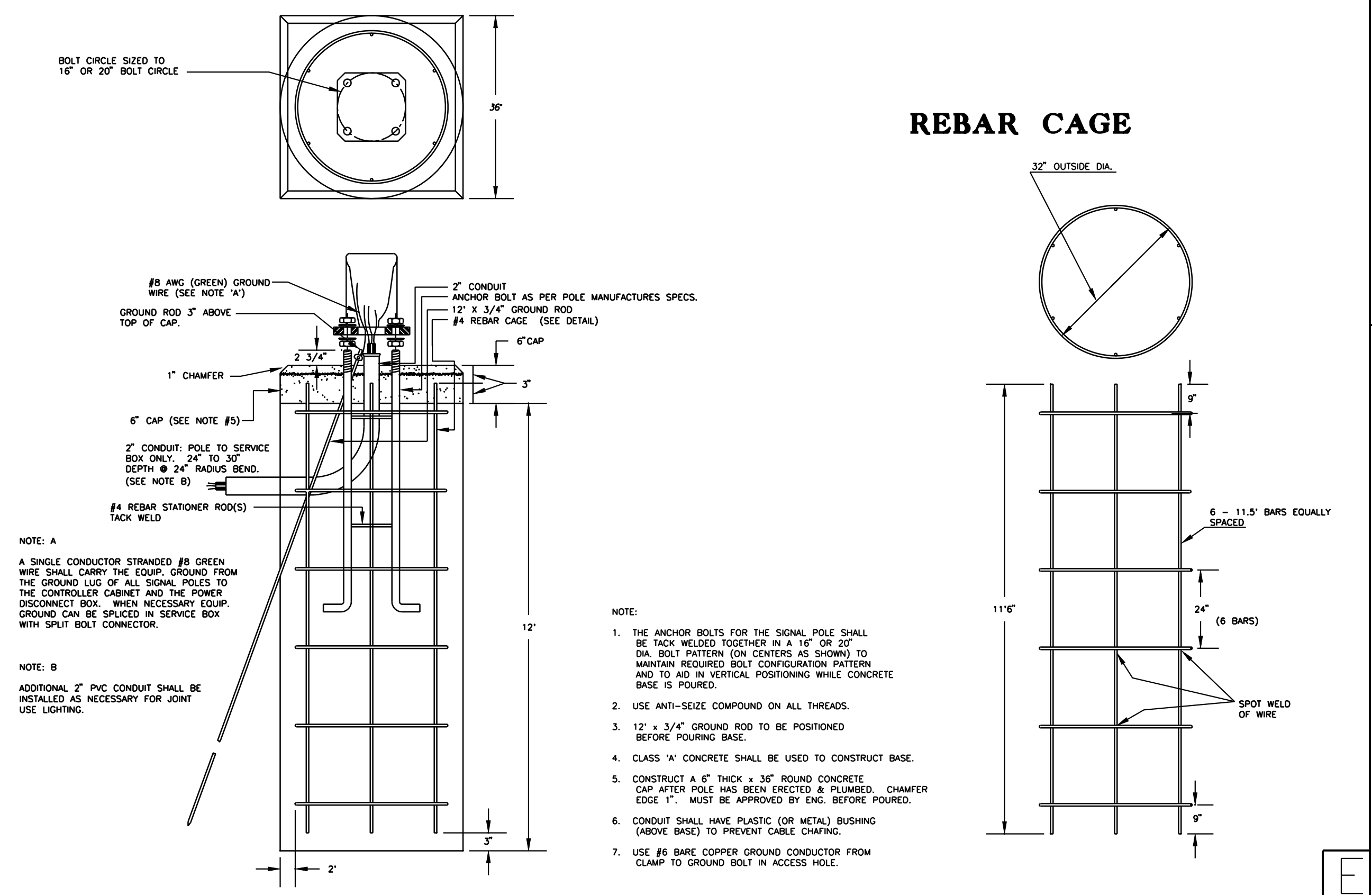

PAWNEE STREET STEEL SIGNAL POLE ASSEMBLY DETAILS		
PROJECT NUMBER 472-84720 PHASE I		
DRAWN BY: T.M.	SCALE	REVISED BY: D.R.M.
DATE: MAY 97	NO SCALE	DATE: OCT 08
CITY OF WICHITA DEPARTMENT OF PUBLIC WORKS		
DIVISION OF TRAFFIC ENGINEERING		
PAUL D. GUNZELMAN P.E.	TRAFFIC ENGINEER	SHEET 4 OF 7