

ELEVATION (SECTION)  
(For connection to left end of Barrier)

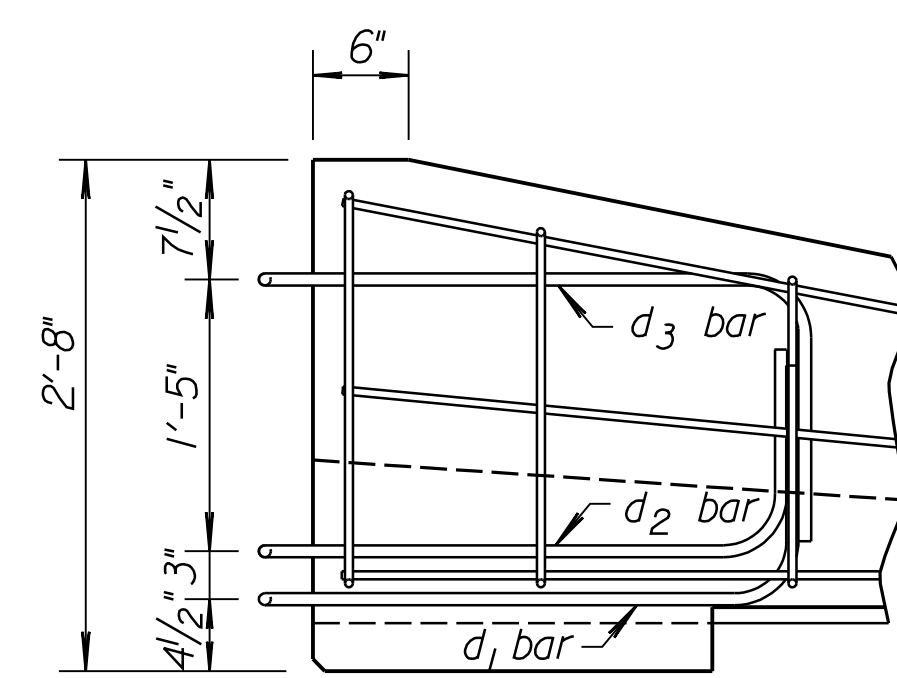

ELEVATION (SECTION)  
(For connection to right end of Barrier)

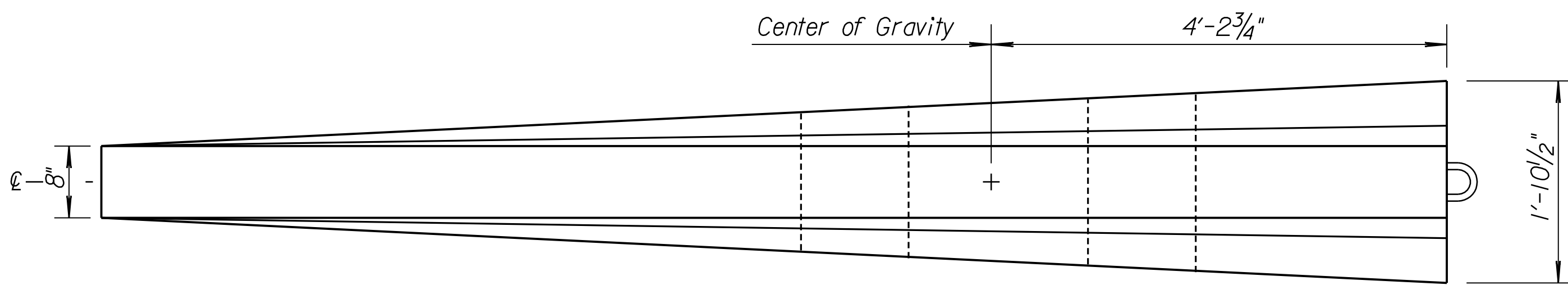

PLAN

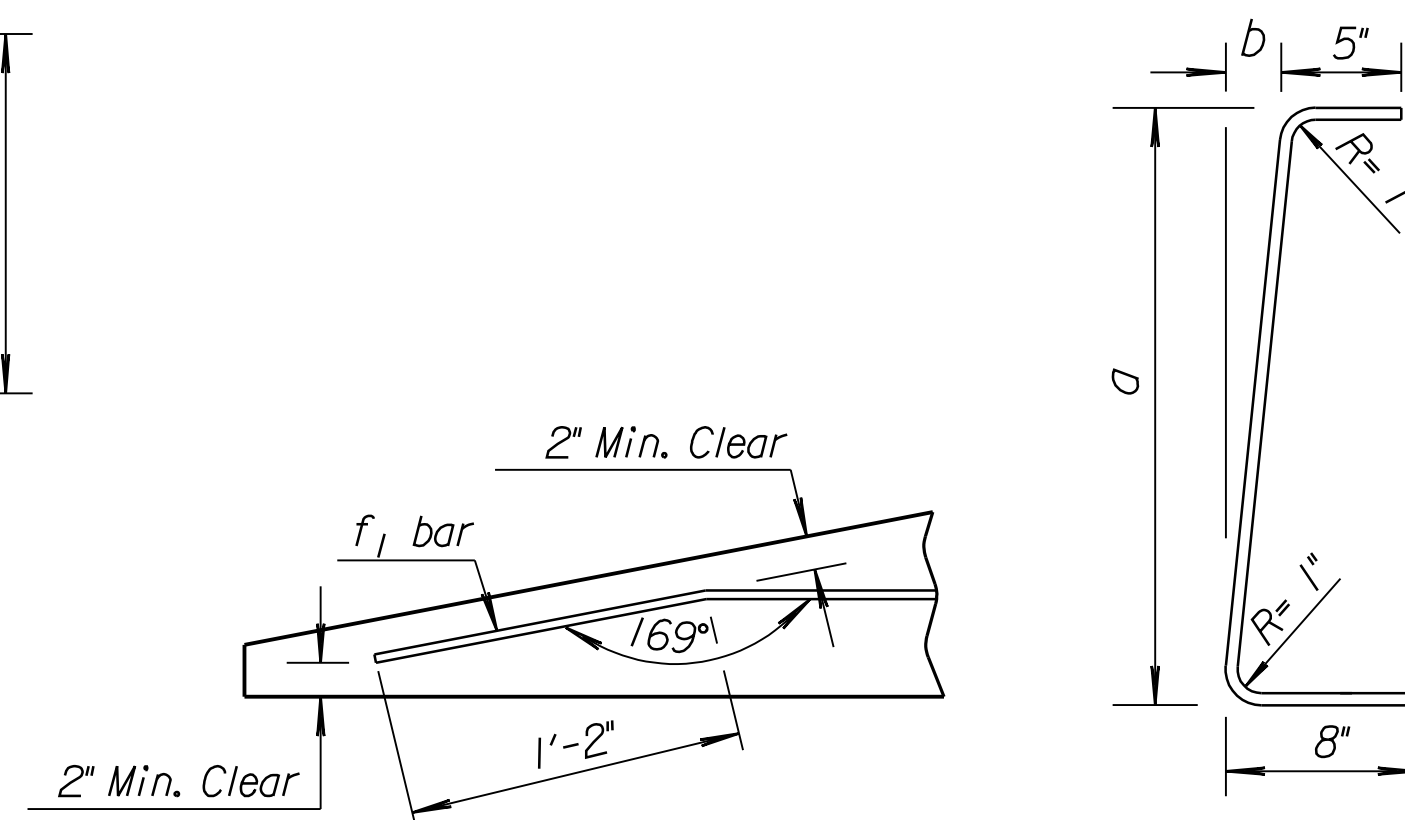

DETAIL "A" BENT BAR DETAIL

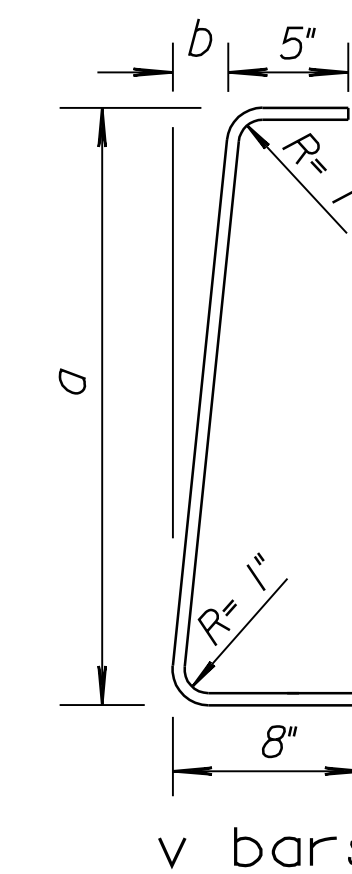

v bars  
2 at each size required for stirrup assembly

Bar	a	b
v <sub>1</sub>	10"	1"
v <sub>2</sub>	1'-1"	1 1/4"
v <sub>3</sub>	1'-5"	1 5/8"
v <sub>4</sub>	1'-8"	1 7/8"
v <sub>5</sub>	2'-0 1/2"	2 3/8"
v <sub>6</sub>	2'-3"	2 3/4"

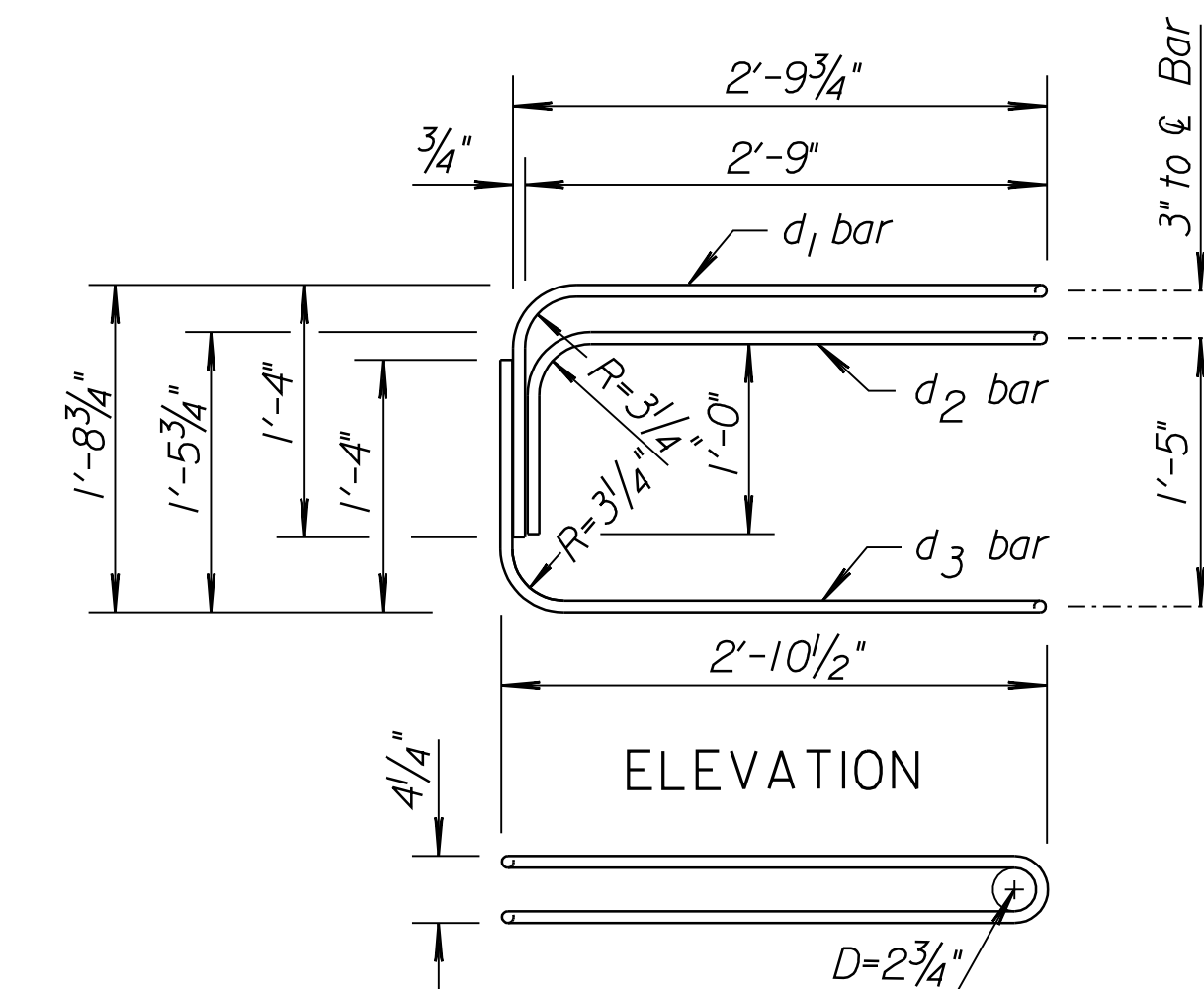

PLAN  
LOOP BAR ASSEMBLY  
(Left Barrier Connection shown, invert for other end)

Note: At no time shall the barriers be lifted, moved, etc. by use of the loop bars: d<sub>1</sub>, d<sub>2</sub> or d<sub>3</sub>.

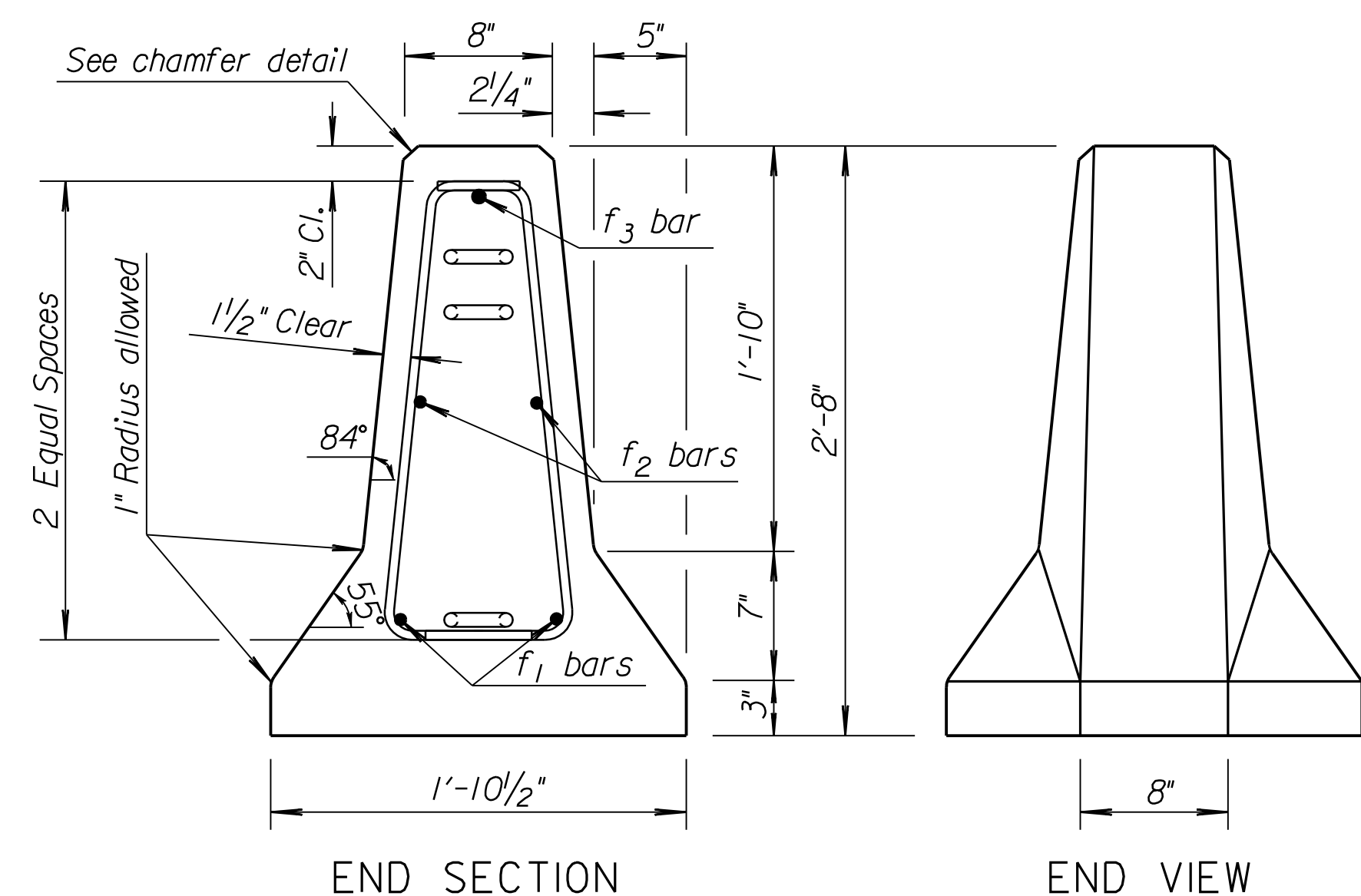

END SECTION

END VIEW

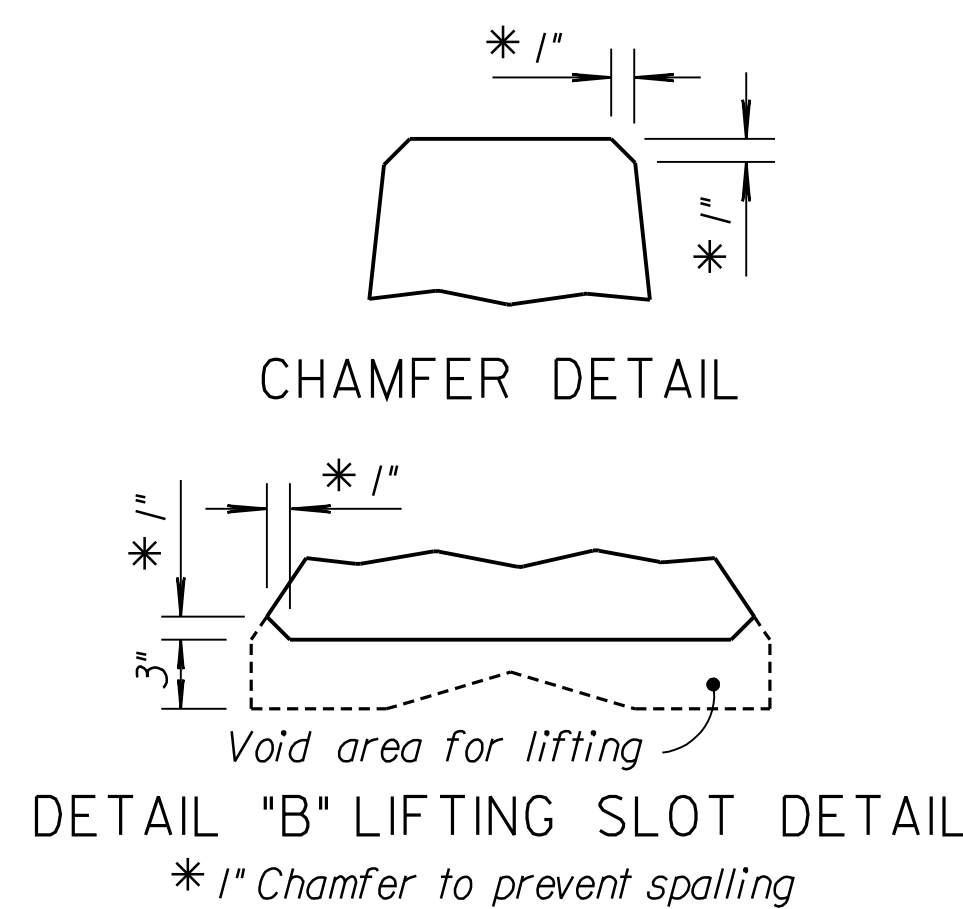

DETAIL "B" LIFTING SLOT DETAIL  
\* 1" Chamfer to prevent spalling

Per 12'-6" Barrier Taper Section

REINFORCING A615 Gr. 60					
Bar	Bar Size	Shape	No. of Bars	Length ft.	Weight lbs.
v <sub>1</sub>	#4	[	2	1'-11"	2.6
v <sub>2</sub>	#4	[	2	2'-2"	2.9
v <sub>3</sub>	#4	[	2	2'-6"	3.3
v <sub>4</sub>	#4	[	2	2'-9"	3.7
v <sub>5</sub>	#4	[	2	3'-2"	4.2
v <sub>6</sub>	#4	[	2	3'-4"	4.5
f <sub>1</sub>	#4	—	2	12'-0"	16.0
f <sub>2</sub>	#4	—	2	7'-6"	10.0
f <sub>3</sub>	#5	—	1	11'-9"	12.3
LOOP ASSEMBLY					
d <sub>1</sub>	#6	⌊	1	8'-5"	12.6
d <sub>2</sub>	#6	⌊	1	7'-7"	11.4
d <sub>3</sub>	#6	⌊	1	8'-6"	12.8

Concrete Quantity = 0.6 C.Y.

**GENERAL NOTES:**  
**MATERIAL:** Use ASTM A615, Grade 60 reinforcing bars, except for the loop bars (d<sub>1</sub>, d<sub>2</sub> and d<sub>3</sub>). The loop bars (d<sub>1</sub>, d<sub>2</sub> and d<sub>3</sub>) shall be 3/4" smooth steel bars with a minimum yield of 60 ksi, a tensile strength of not less than 1.25 times the yield strength but a minimum of 80 ksi, a minimum 14% elongation in 8 inches, and passing a 180 degree bend test using a 3.5"D pin bend diameter. The loops shall be installed within 1/8" of the plan dimensions.  
 Use air-entrained concrete with f'c = 5,000 p.s.i.  
**SECTION:** The section furnished must generally comply with dimensions shown. Requests for minor variations in section geometry and attachments may be submitted to the Engineer for approval.  
**LIFTING SLOTS:** Lifting slots shall be constructed where specified on the plans to facilitate the drainage of water after installation on the roadway.  
**TEMPORARY CONCRETE SAFETY BARRIER:** One section of Taper Barrier shall be bid as one section of Type F3 Barrier. Type F3 barrier taper sections shall be used only for low speed (40 mph or less) applications or where a barrier terminates beyond the roadway clear zone. Where a barrier terminates within the clear zone of a high speed roadway, an appropriate impact attenuator shall be installed on the approach end. Furnishing and placing of all materials when required and all labor and equipment required to position the temporary barrier shall be included in the Contract unit price bid for "Concrete Safety Barrier (Type F3)(Temporary)". Any relocation of the barrier required for the project shall be paid in accordance with the Special Provisions under the bid item "Concrete Safety Barrier (Type F3)(Temporary-Relocate)". Unless otherwise noted on the Plans, the Temporary Concrete Safety Barrier shall become the property of the Contractor and shall be removed from the site upon acceptance of the completed project. Approximate weight of one unit equals 1.3 tons.  
**SURFACE PREPARATION:** Barrier shall be placed on a paved surface. All loose dirt and sand shall be removed from the roadway surface just prior to placement of the barrier.  
**MARKING:** Each barrier shall be permanently marked by stamping or forming into the barrier the following information:  
 - Type F3  
 - Manufacturer code (as specified by KDOT Bureau of Const. & Maint.)  
 - Date manufactured (month and year)

KANSAS DEPARTMENT OF TRANSPORTATION				
TEMPORARY CONCRETE SAFETY BARRIER TAPER SECTION TYPE F3				
RD622A				
DESIGNED	DATE	REVISIONS	BY	APP'D
1	1-10-07	Revised layout & notes	S.W.K.	J.O.B.
2				
3				
4				
5				
6				
7				
8				
9				
10				
11				
12				
13				
14				
15				
16				
17				
18				
19				
20				
21				
22				
23				
24				
25				
26				
27				
28				
29				
30				
31				
32				
33				
34				
35				
36				
37				
38				
39				
40				
41				
42				
43				
44				
45				
46				
47				
48				
49				
50				
51				
52				
53				
54				
55				
56				
57				
58				
59				
60				
61				
62				
63				
64				
65				
66				
67				
68				
69				
70				
71				
72				
73				
74				
75				
76				
77				
78				
79				
80				
81				
82				
83				
84				
85				
86				
87				
88				
89				
90				
91				
92				
93				
94				
95				
96				
97				
98				
99				
100				