

GENERAL NOTES

The details depicted here may not be appropriate for all locations. Designs shall meet this criteria on all new construction projects unless impracticable by site restrictions. For an existing sidewalk facility where the sidewalk will be replaced, this sidewalk will be replaced according to this drawing to the maximum extent feasible.

Ramps shall be provided at all corners of street intersections where there is existing or proposed sidewalk and curb. Ramps shall also be provided at walk locations in mid-block in the vicinities of hospitals, medical centers and athletic stadiums.

Details shown on this sheet apply to all construction or reconstruction of streets, curbs or sidewalks. See KDOT Standard Specifications for additional information.

Use of sidewalk ramp Type 2 shall be restricted to locations where it is not feasible to use Types 1 or 3.

Curb cut ramps are to be located as shown on the plans or as directed by the Engineer.

If possible, drainage structures should not be placed in line with ramps. Except where existing drainage structures are being utilized in the new construction, location of the ramp should take precedence over location of drainage structure.

Sidewalks shall be ramped where the driveway curb is extended across the walk. Care shall be taken to assure a uniform grade on the ramp, free of sags and short grade changes.

Expansion joints shall be placed in sidewalks as follows: In long runs, expansion joints shall be 2" redwood boards flush with the surface at a maximum spacing of 125'. This same joint should be used at sidewalk junctions as shown in Typical Plan.

Where the end of the sidewalk abuts a curb, a 2" redwood board flush with the surface shall be used.

Where the sidewalk is parallel and adjacent to a rigid structure, a 2" pre-molded joint filler (Non-extruding, Type B) shall be used.

Sidewalk shall slope toward the street at a 50:1 or flatter, and where necessary, may be depressed or sloped to fit alleys and entrances as shown on the plans or as directed by the Engineer.

Where clear width of sidewalk between top of ramp and building or other obstruction is less than 48 inches, the slope of the flared sides shall be 12:1 or flatter.

Where sidewalk is shown to be constructed back of an entrance it shall be 6" thick with welded wire mesh reinforcement of the same gauge and spacing of wires as in entrance pavement, as shown in the Reinforcement Diagram. Bid item will be "Sidewalk Construction (6") either with or without air entrainment.

At the Contractor's option Concrete Grade 3.0 (AE) may be used throughout for construction of steps, but payment will be paid under the bid item "Grade 3.0 Conc. (misc.)".

Surface texture of the ramp shall be that obtained by a wooden float or brushed finish to the slope of the ramp.

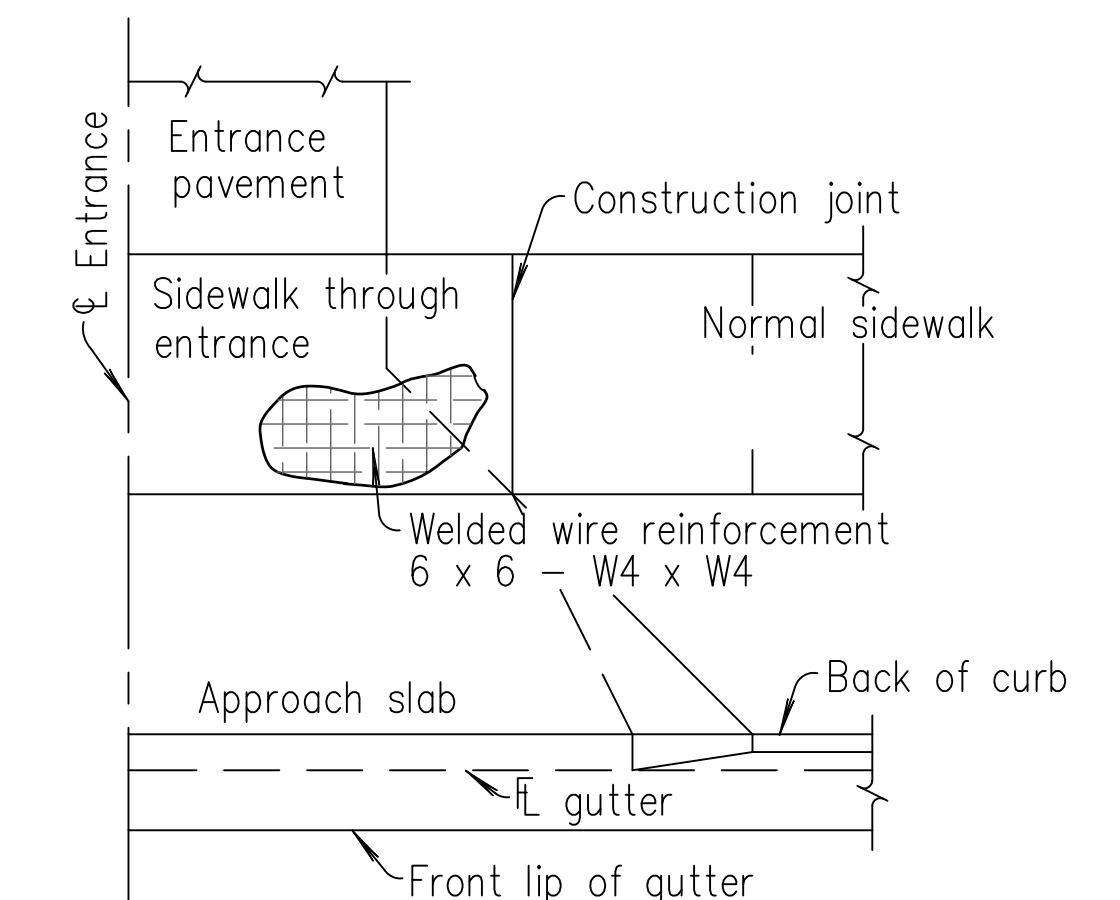

**REINFORCEMENT DIAGRAM
SIDEWALK THROUGH ENTRANCE**

See Std. Drawing RD726 for details of Alley and Entrance Pavement.

LEGEND

- Sidewalk Ramp Type 1
- Sidewalk Ramp Type 2
- Sidewalk Ramp Type 3
- Preferred location of drainage inlet (Typical)
- Alternate location of drainage inlet (Typical)
- Sidewalk

NO.	DATE	REVISIONS	BY	APP'D
8	7-30-08	Reorg. layout, added steps sheet	S.W.K.	J.O.B.
7	1-28-05	Changed Class to Grade concrete	S.W.K.	J.O.B.
6	8-20-03	Revised notes and details	S.W.K.	J.O.B.
5	6-2-03	Added Detectable Warning details	S.W.K.	J.O.B.

KANSAS DEPARTMENT OF TRANSPORTATION

SIDEWALK & STEPS

RD725		APP'D. James O. Brewer	
DESIGNED	6-30-09	DETAILED	QUANTITIES
DESIGN CK.	DETAIL CK.	QUAN. CK.	TRACE CK.

SECTION J-J See Std. RD725B for details of Steps and Handrail.

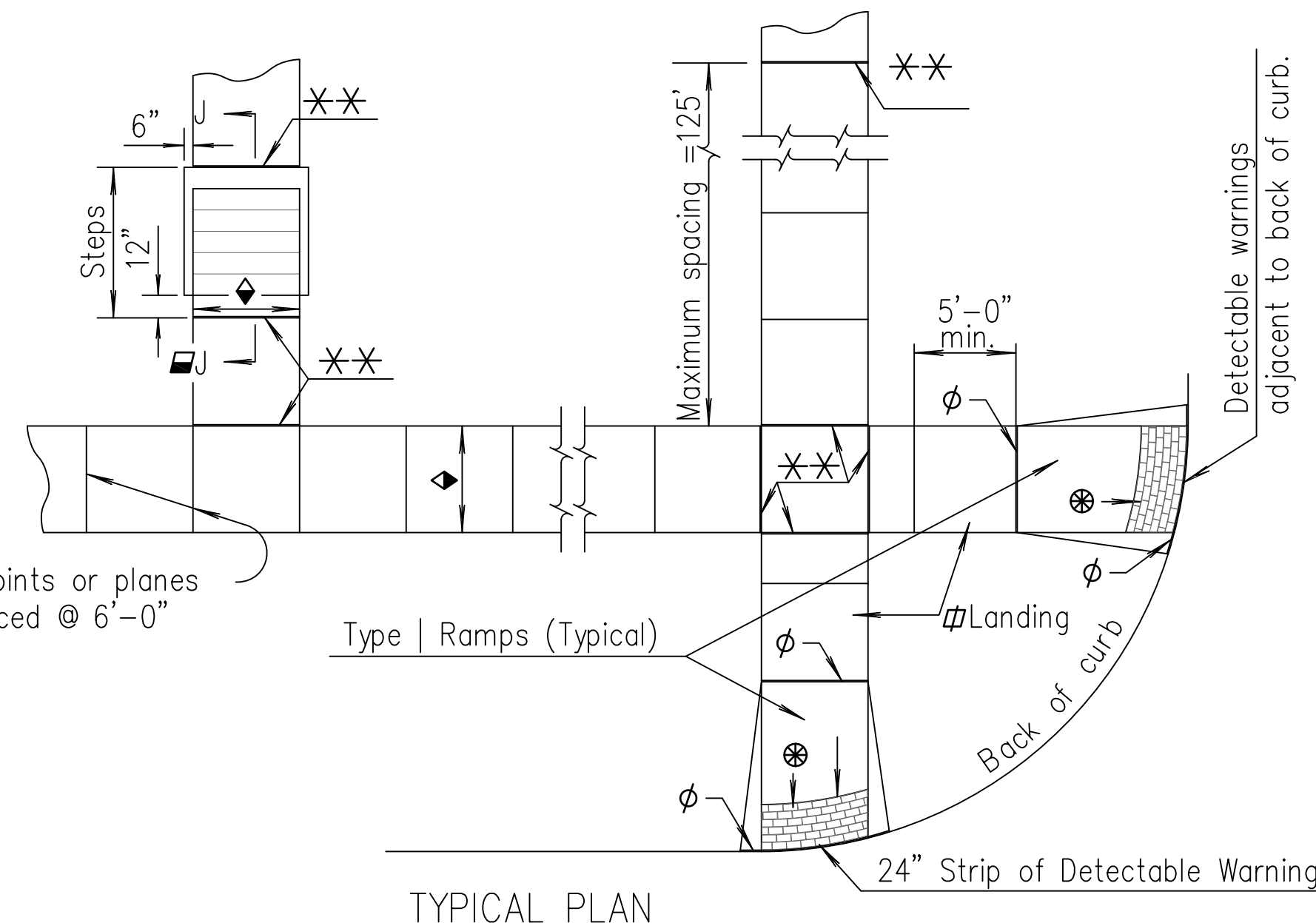

TYPICAL PLAN

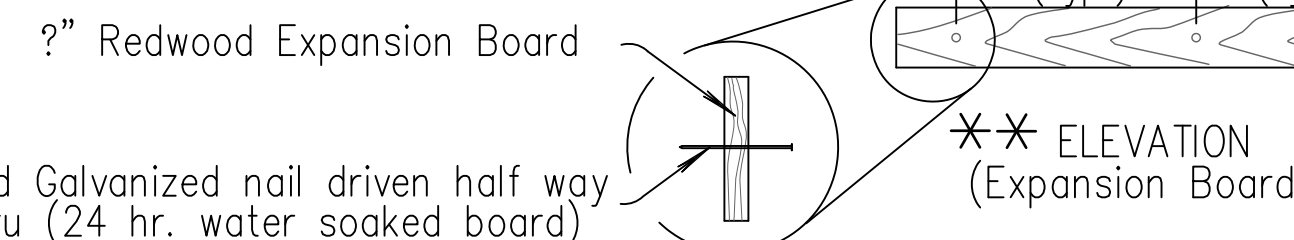

For other than 5'-0" (width) use 6" from the end and balanced (3'-0" max.) nail spacing.

Expansion Joint (2" Redwood board) placed at either back of curb line or at sidewalk back of curb line or at sidewalk line.

Expansion joint (2" redwood board) located as shown.

Variable width (5'-0" min.). Entrance walk to be same width as approach walk. Sidewalk width of 4'-0" may be used where existing conditions prohibit use of 5'-0".

Ramp slopes in new construction shall be 12:1 or flatter. Desirable ramp slopes on existing sites shall be 12:1 or flatter. Where space limitations prohibit construction of 12:1 slopes at existing sites slopes shall be as follows:
8:1 or flatter for a maximum rise of 3 inches
10:1 or flatter for a maximum rise of 6 inches

Landing slopes shall be 48:1 or flatter. Landings shall be the same width as the ramp and min. 5'-0" in length.

The counter slope shall be 20:1 or flatter at the base of sidewalk ramps. Refer to standard drawing RD725A for additional curb and gutter details.

Detectable warning installation is typical and required on Sidewalk Ramps Type 1, Type 2, Type 3, median ramp crossings and other locations as shown in the plans. Refer to standard drawing RD725A for additional details.

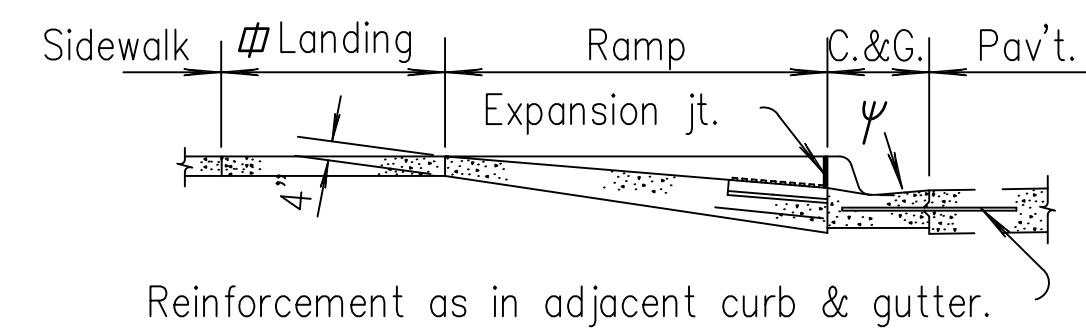

SECTION A-A

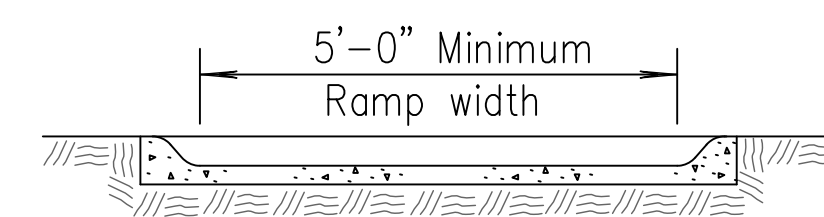

SECTION B-B

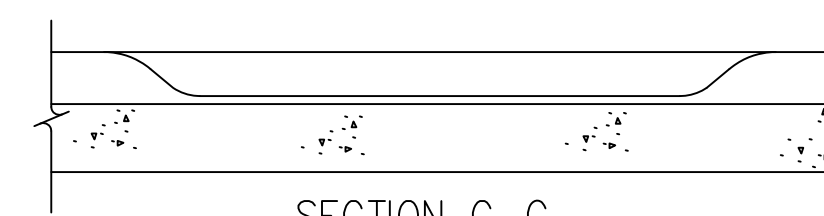

SECTION C-C

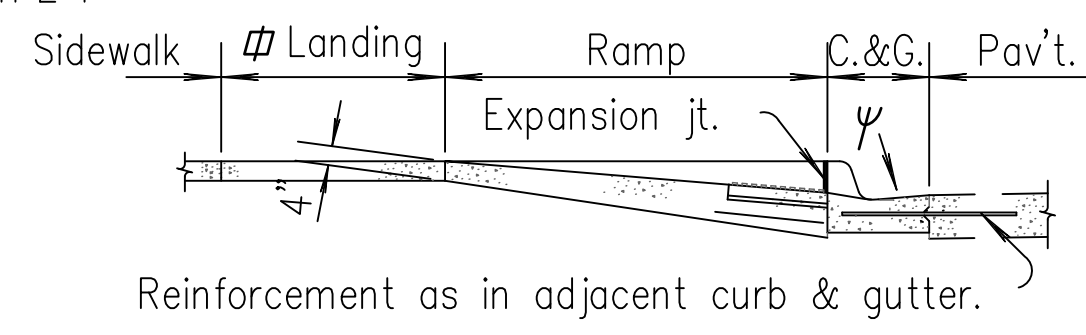

SECTION D-D

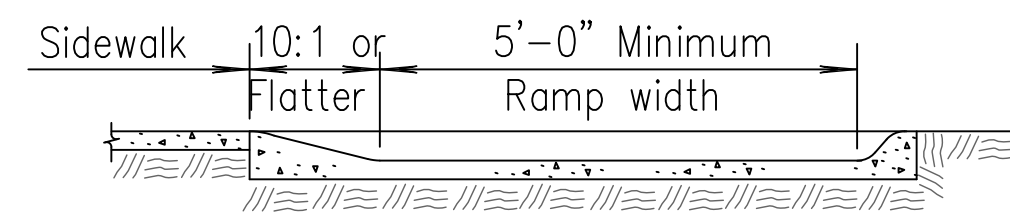

SECTION E-E

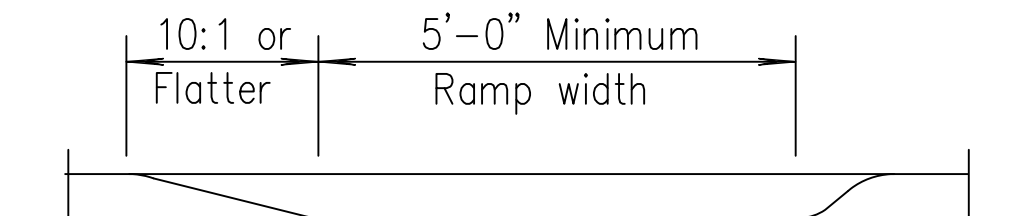

SECTION F-F

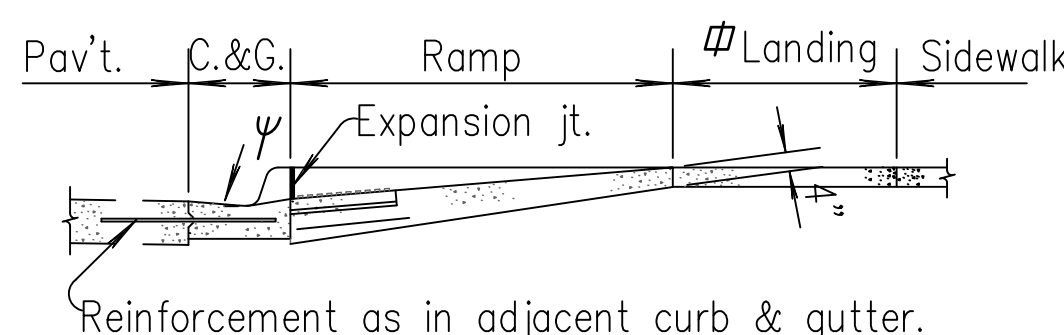

SECTION G-G

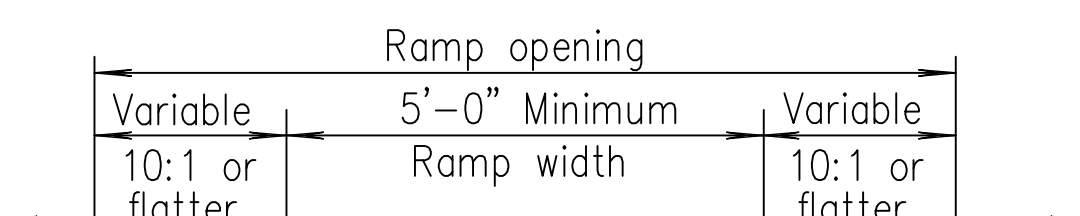

SECTION H-H

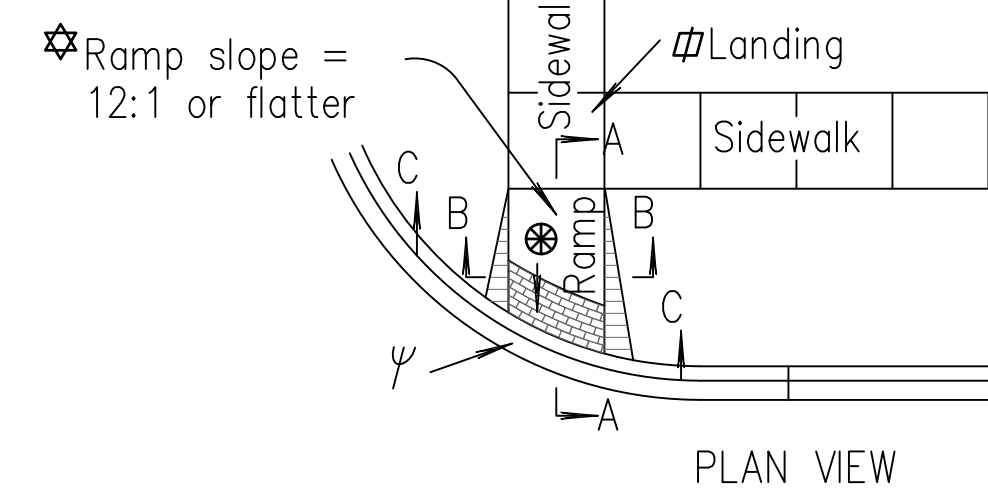

PLAN VIEW

Place expansion joint at back of curb line or at sidewalk line.

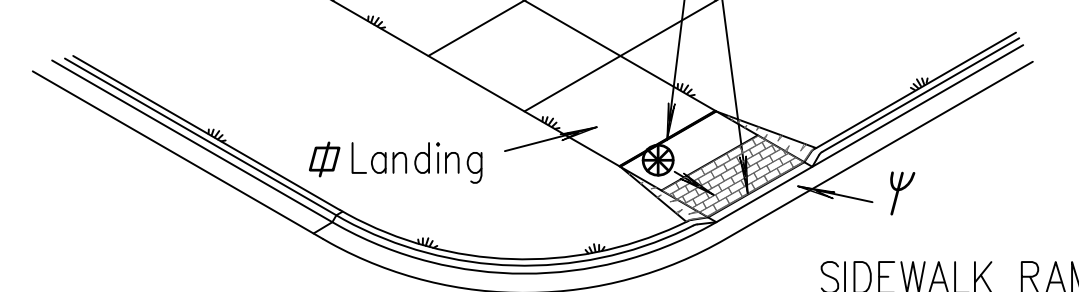

SIDEWALK RAMP TYPE 1

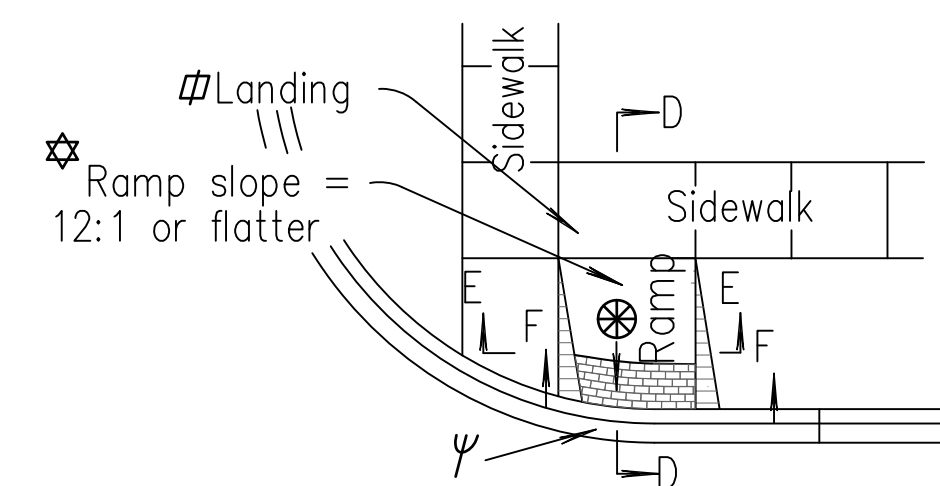

PLAN VIEW

Place expansion joint at back of curb line or at sidewalk line.

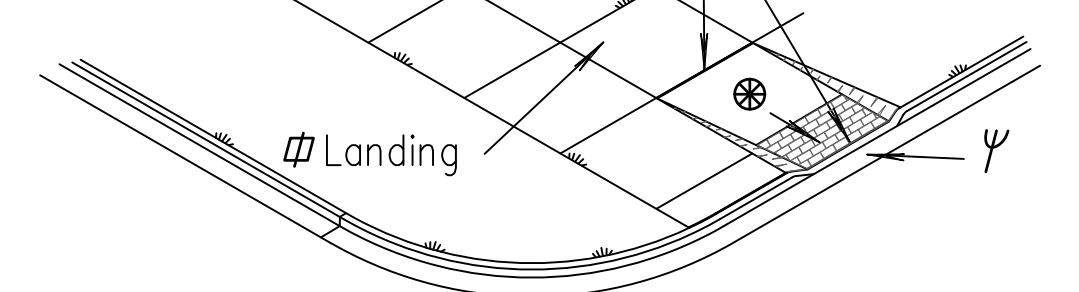

SIDEWALK RAMP TYPE 2

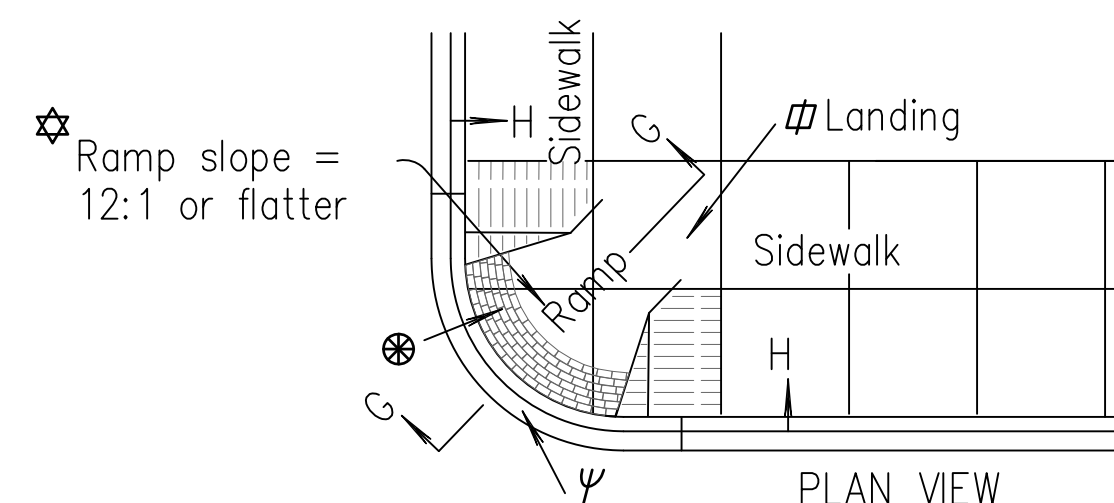

PLAN VIEW

2'-0" Straight curb behind ramp.

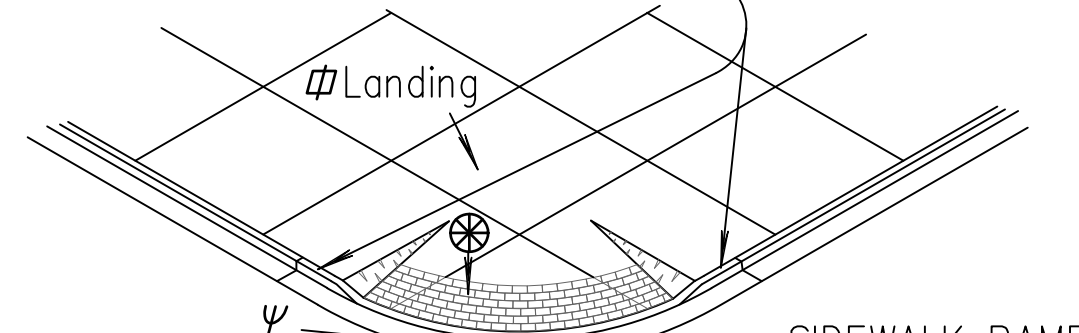

SIDEWALK RAMP TYPE 3

To be used where sidewalk occupies entire area between curb and property line.

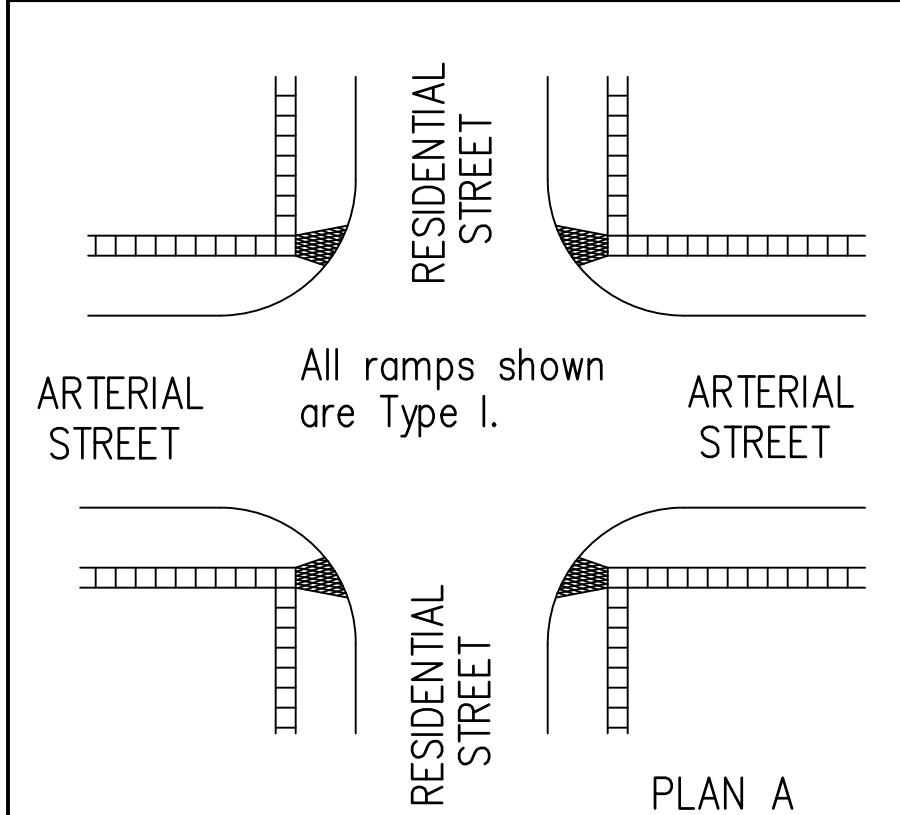

PLAN A

Heavy Traffic on Arterial
No Traffic Signal

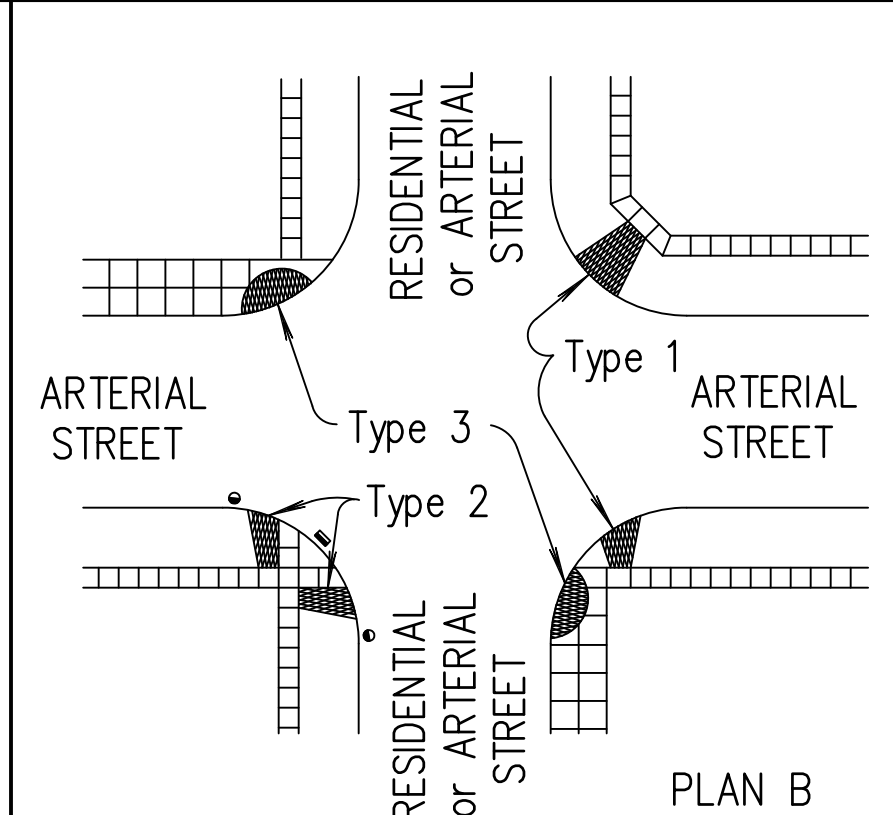

PLAN B

Signalized Intersection
Typical Ramp Treatments

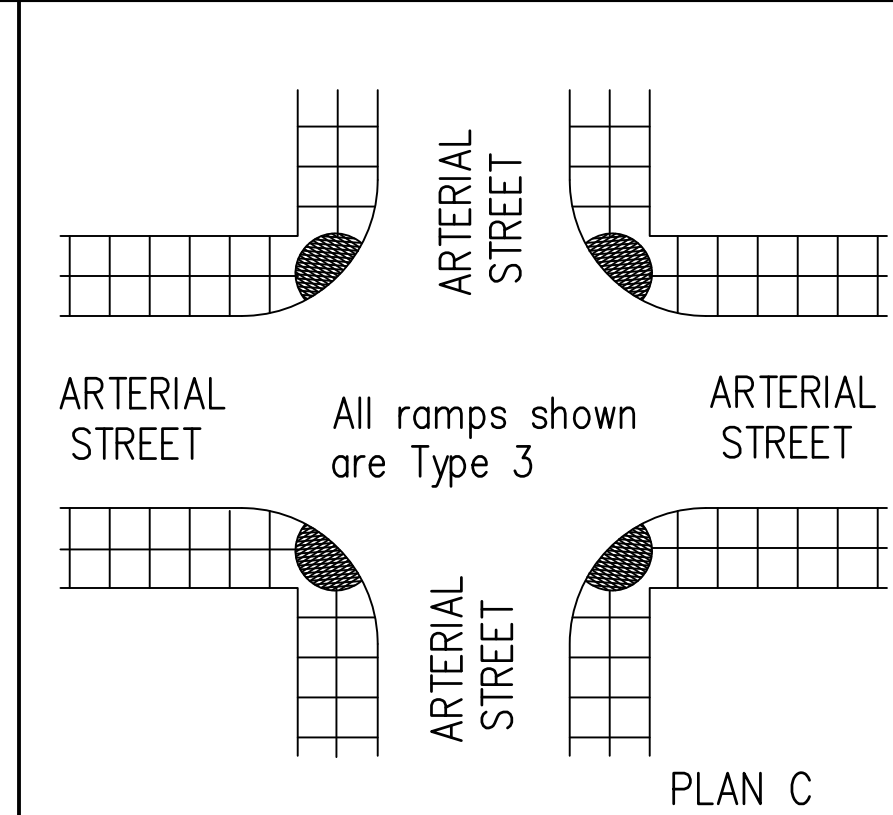

PLAN C

Traffic Control on Both Streets
Wide Sidewalks

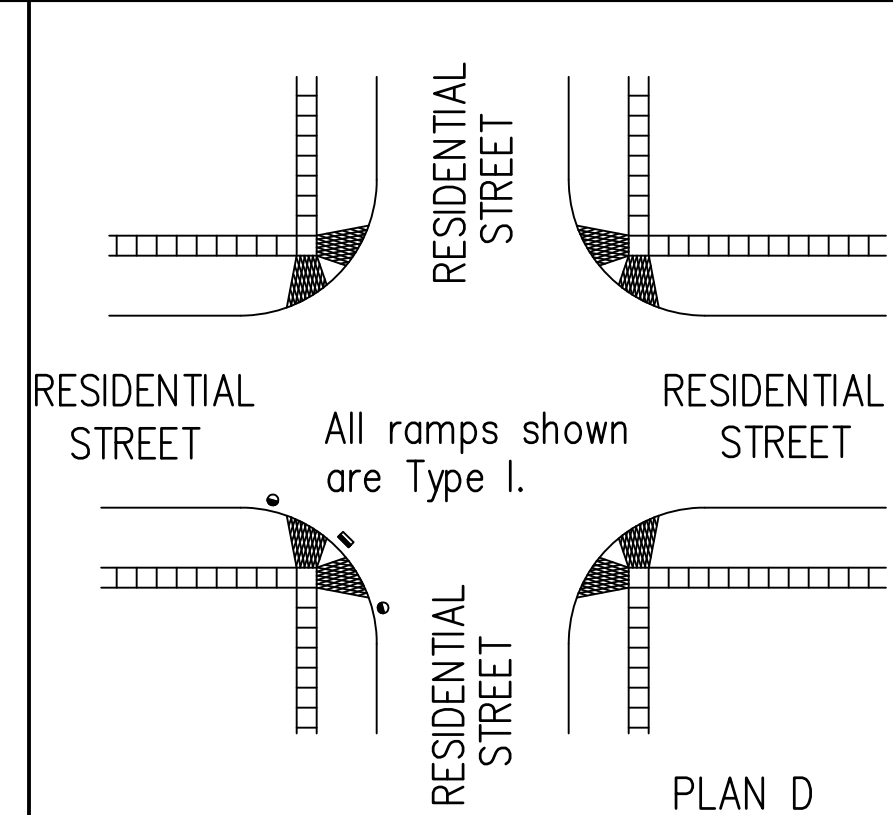

PLAN D

Normal Treatment in Residential Area

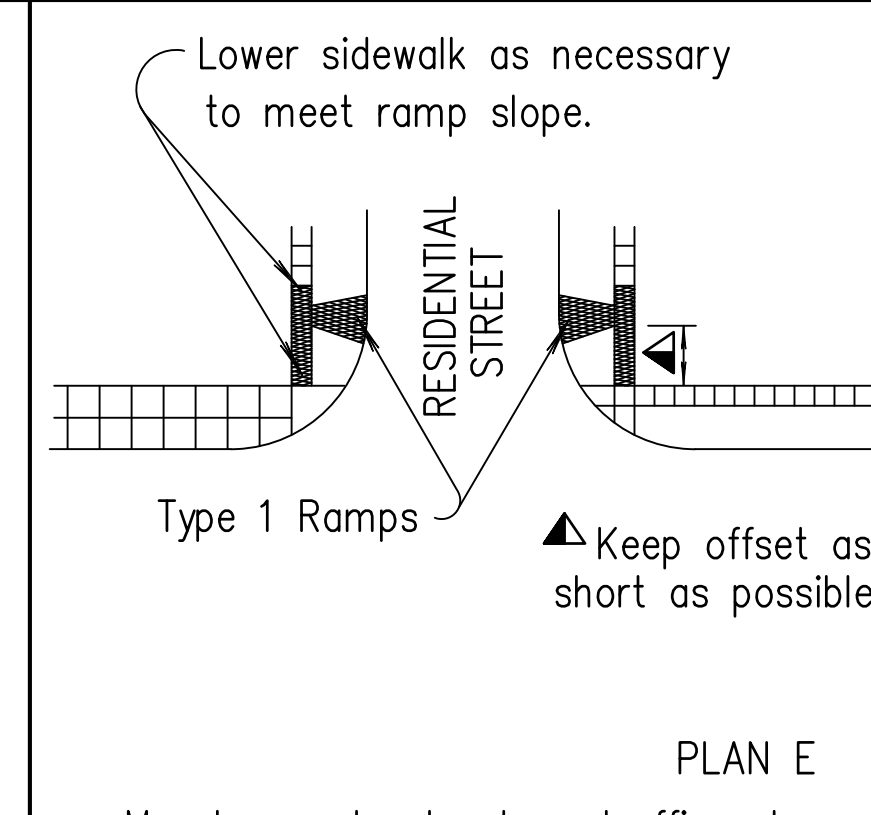

PLAN E

May be used only where traffic volume is low and where other features make Plan D impractical.

Keep offset as short as possible.