

J:\2008Proj\08527\DWG\Structural\DWG\S17.dwg 11/10/2009 - 1:55pm hphm

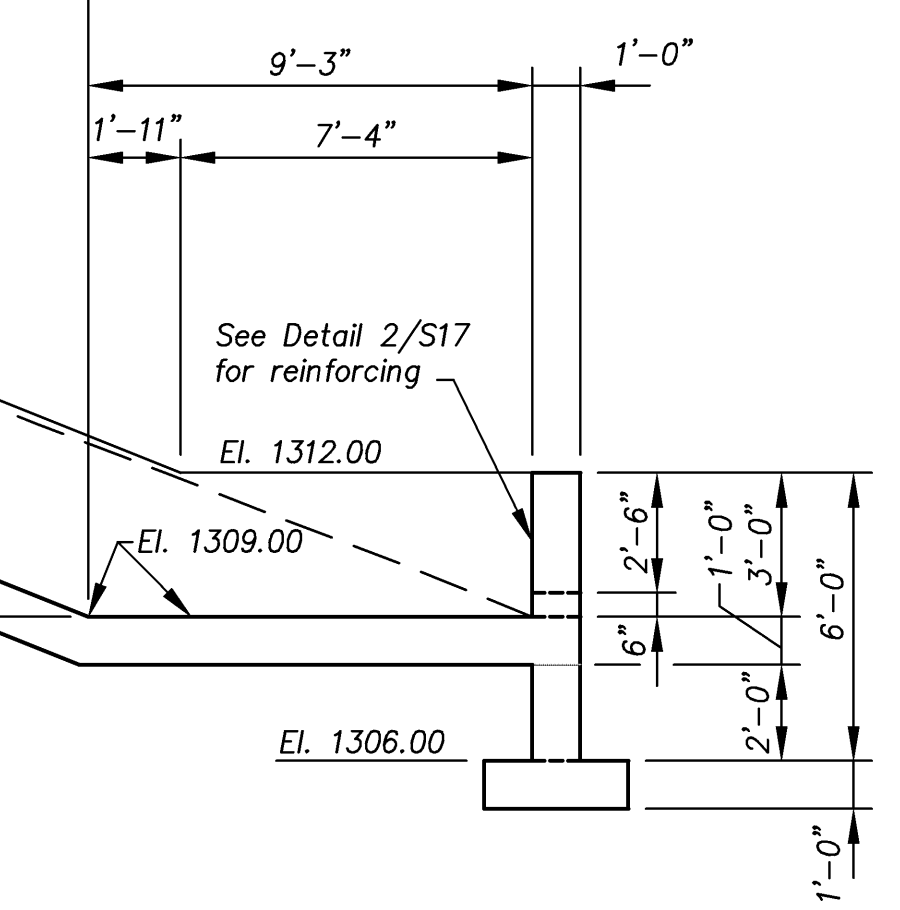
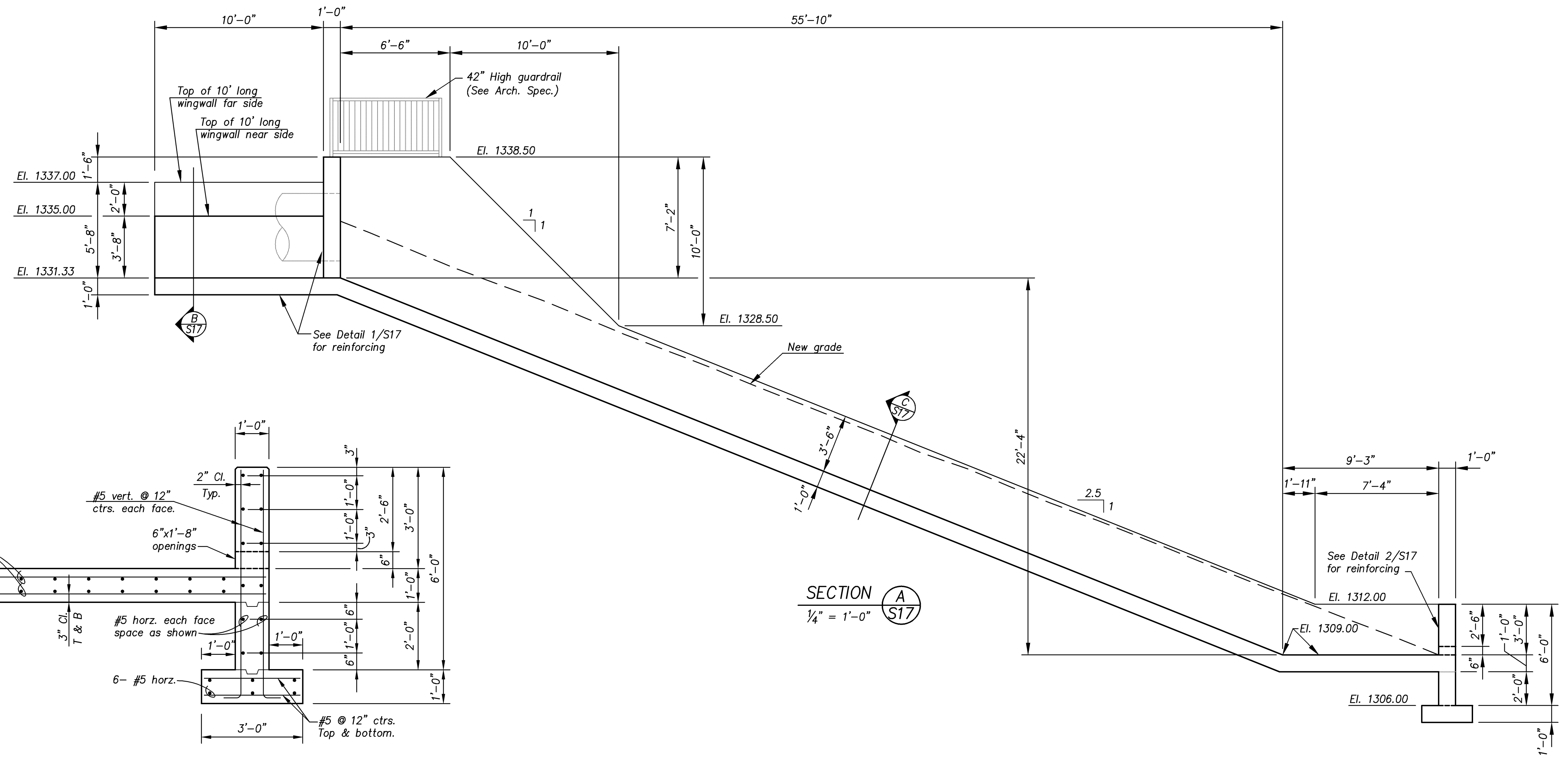
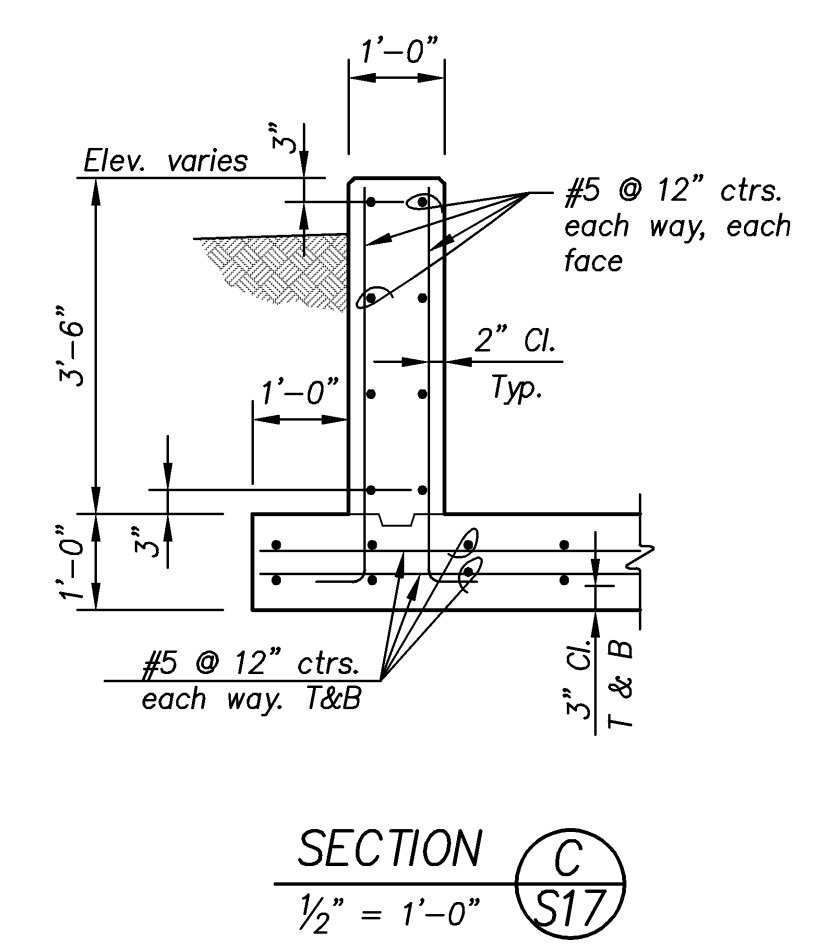
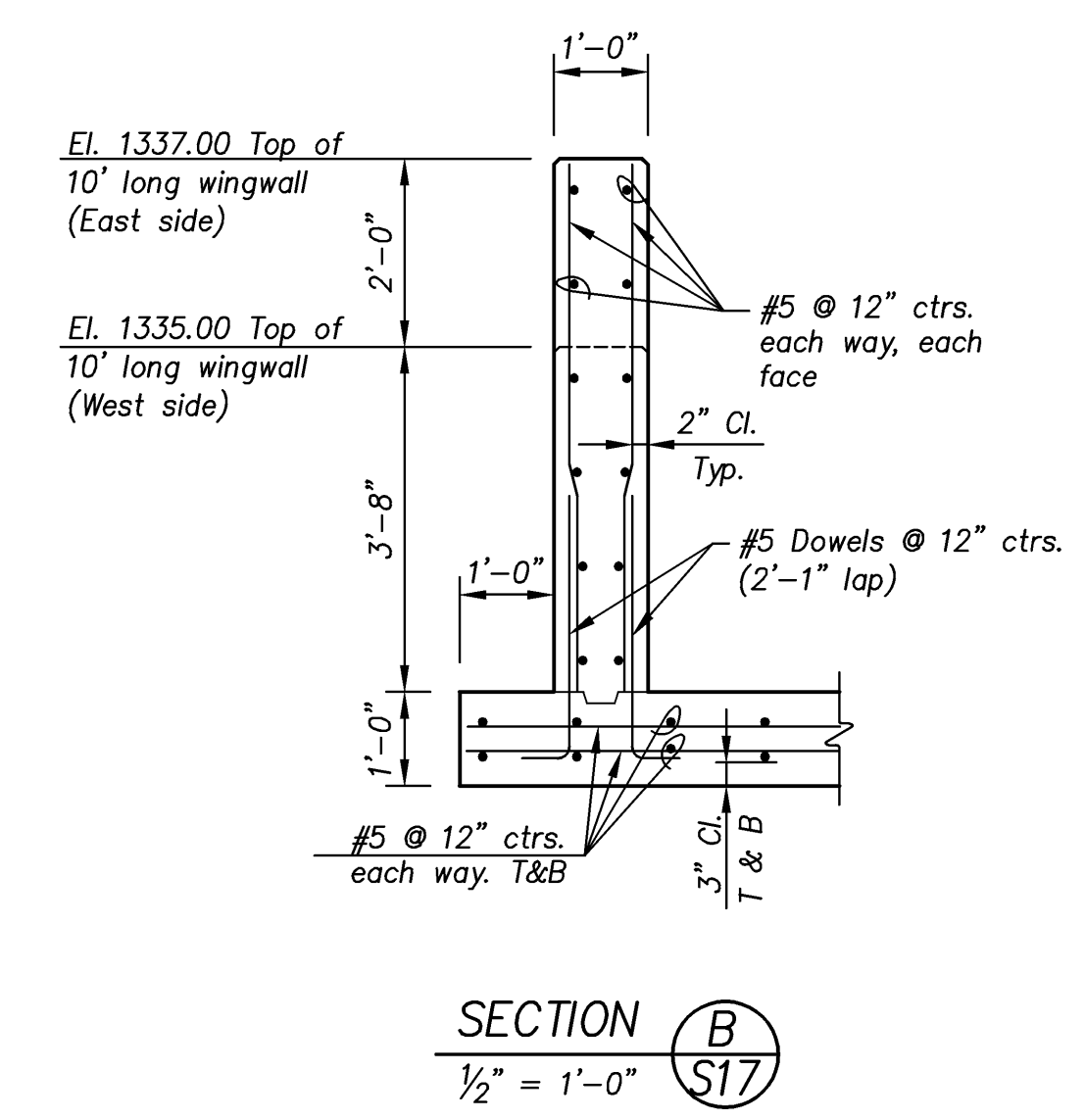
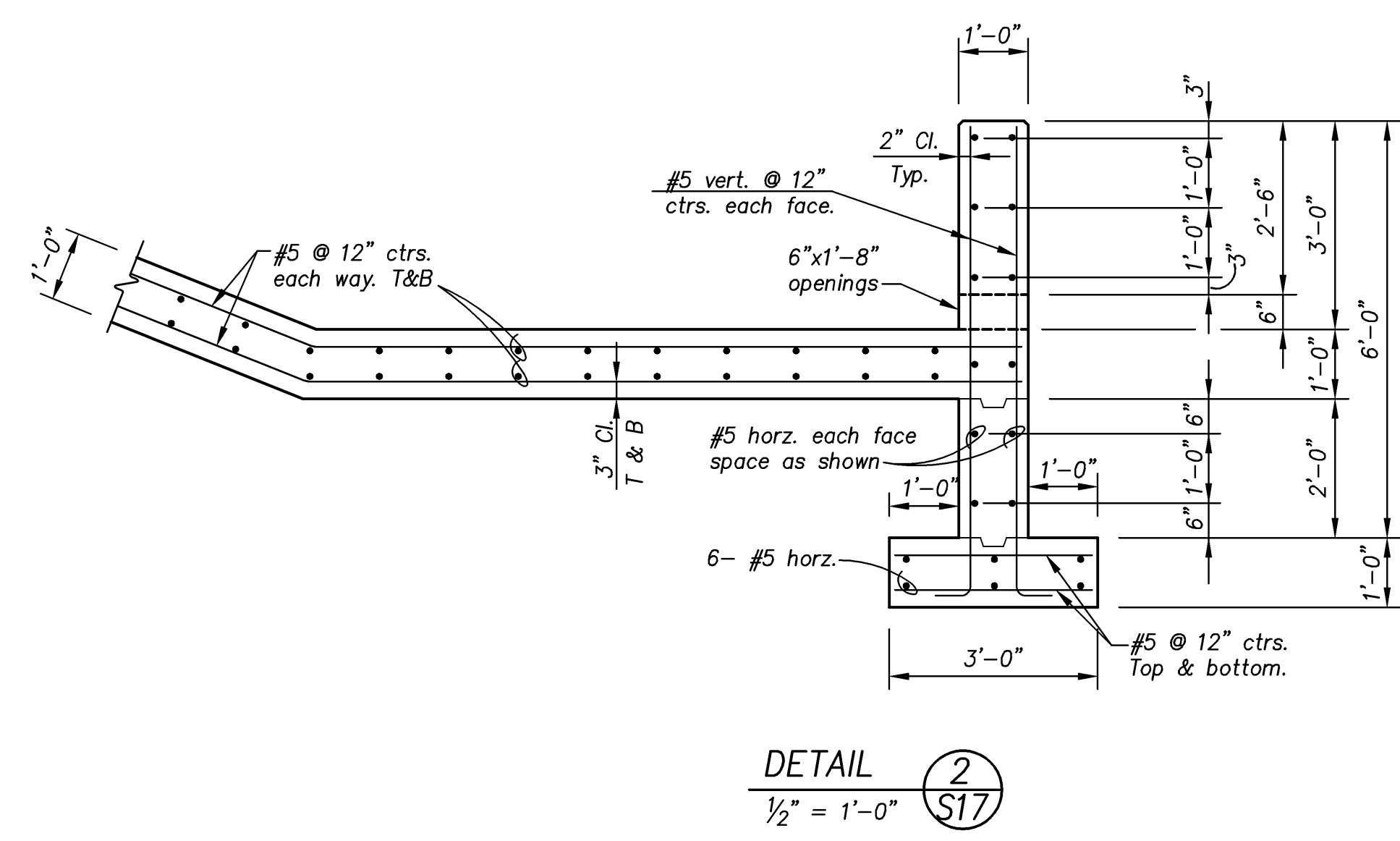
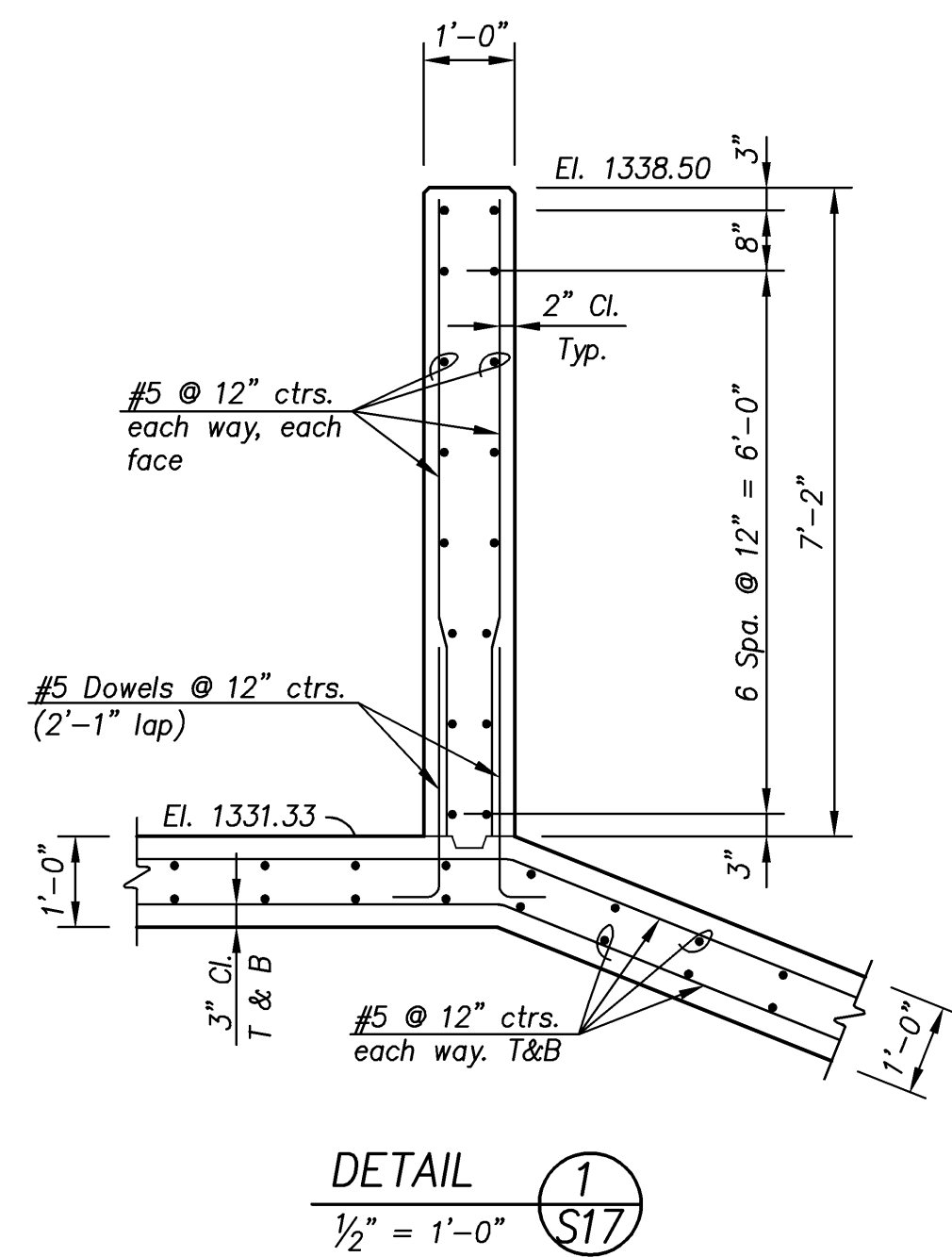

| | | |
|----------------------------|--|---|
| CITY OF WICHITA, KANSAS | | CFS Cook, Flatt & Strobel ENGINEERS, P. A. |
| PUMP STATION NO. 11 | | |
| STRUCTURAL | | DESIGNED KMB SCALE As Shown |
| OUTFALL STRUCTURE SECTIONS | | Detailed HAP DATE 10-30-09 |
| | | CHECKED SHEET S17 OF S17 |