

SECTION A-A

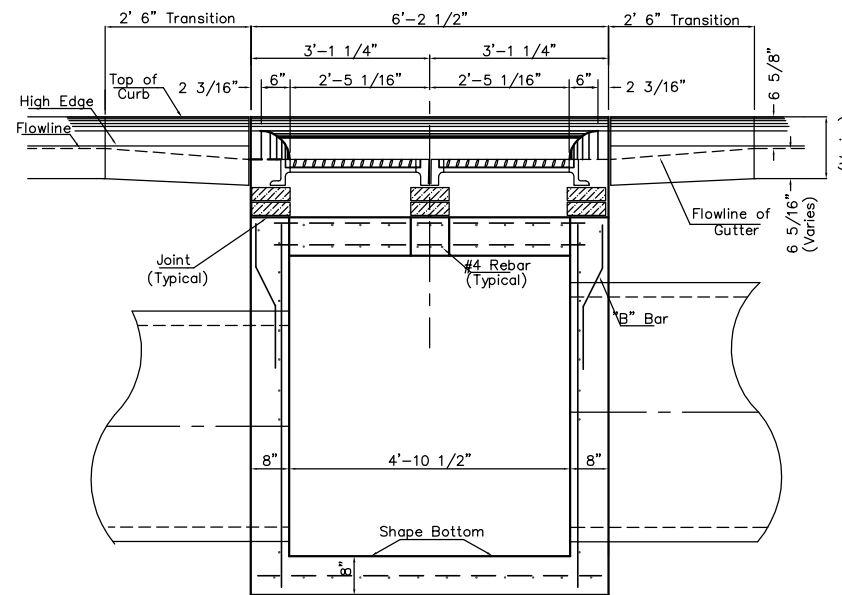

SECTION C-C

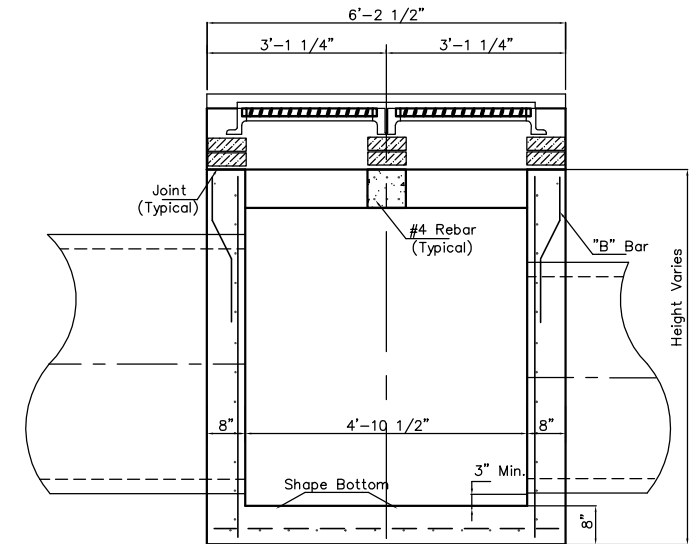

SECTION D-D

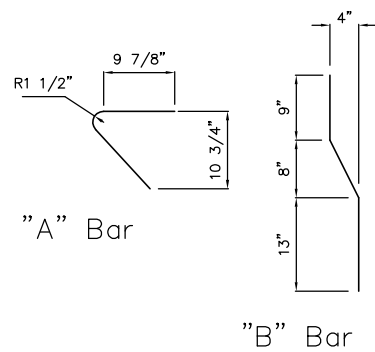
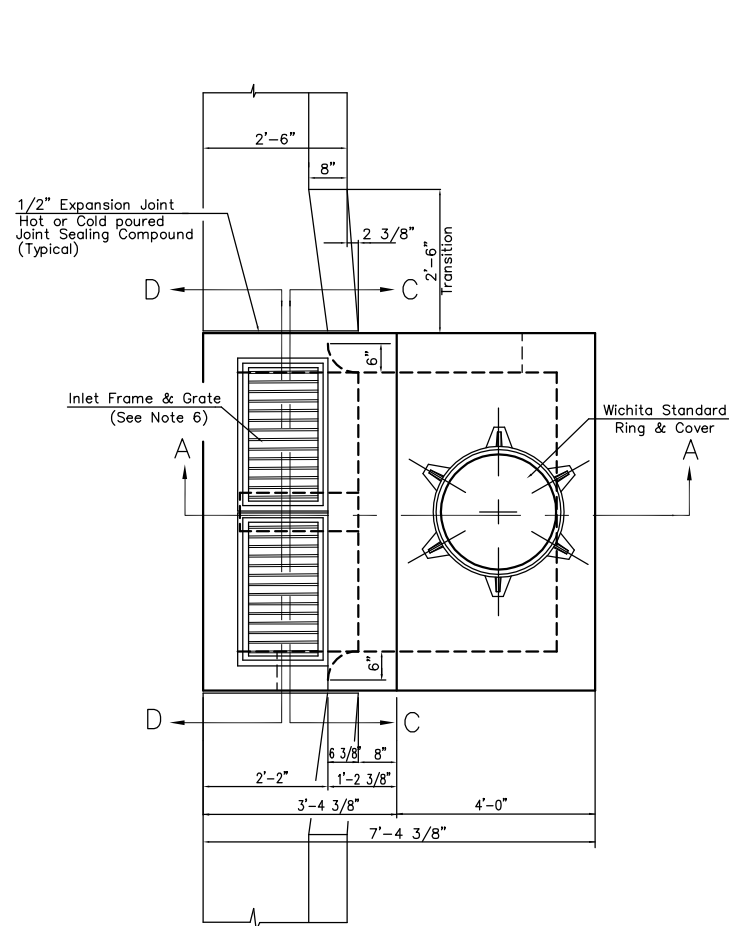

REAR WALL

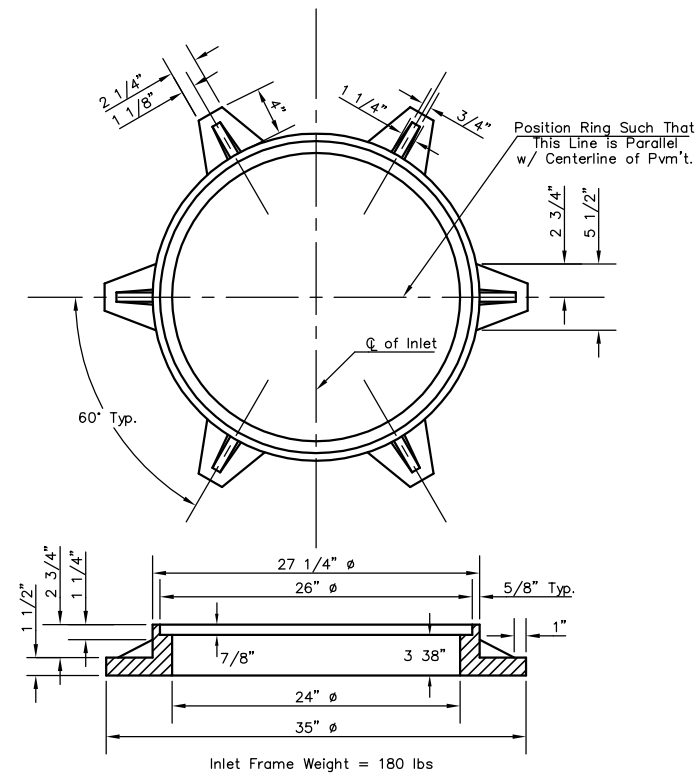
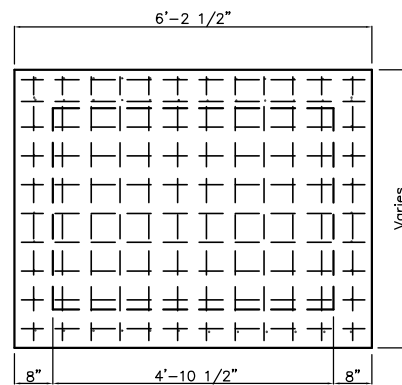

MANHOLE RING AND COVER

\*See City of Wichita Standard Manhole Ring and Cover Detail Sheet for Cover Details to Be Used With Inlet Frame.

General Notes

1. Use the concrete mix specified for the City of Wichita concrete pavement throughout. All exposed edges shall be finished with an edging tool. Reinforcing bars shall be bent around pipe.
2. Inlet invert shall be shaped with 8 sack mix concrete to create flow channels and to increase hydraulic efficiency such that the inlet will be self cleaning between all inlet and/or outlet pipes.
3. All bars are #4 with 6" spacing and shall have a minimum clearance of 1 1/2" inches unless otherwise noted on the plans.
4. No deductions will be made in pay length of curb, gutter, or curb and gutter through the inlet area.
5. Use Neenah R-3288 HV Inlet Frame w/ two piece Grate or approved equal. Inlet frame to be proof load tested to 40,000 lbs. on unsupported side.
6. Reinforcing bars shall be cut or bent around pipes. No deduction in concrete quantities shall be made for pipe openings.
7. The vanes of the grate shall be oriented with respect to the flow arrows shown on the plans.
8. Around manhole opening in top slab use #5 bar @ 45° angle to other bars. Length = MH opening + 2'0"

J:\CIVIL\03392\dwg\details\TYPE2DBL.DWG 7/13/2004 2:39:13 PM CST

THE CITY OF WICHITA

CITY ENGINEER'S OFFICE  
CITY HALL - SEVENTH FLOOR  
455 NORTH MAIN STREET  
WICHITA, KANSAS 67202  
(316) 268-4501  
(316) 268-4114 FAX

**SPECIAL TYPE II  
INLET/MANHOLE  
INLET OPENING  
6" x 4'-10 1/8"**

JIM ARMOUR, P.E. - CITY ENGINEER

PROJECT NUMBER: 87 N-0307-01 INDEX CODE: XXXXXX

DATE: MAR 96 SHEET 38 OF 89