

F.H.W.A. REGION NO.	STATE	PROJECT NO.	FISCAL YEAR	SHEET NO.	TOTAL SHEETS
7	KANSAS	87 N-0306-01	2005	20	111

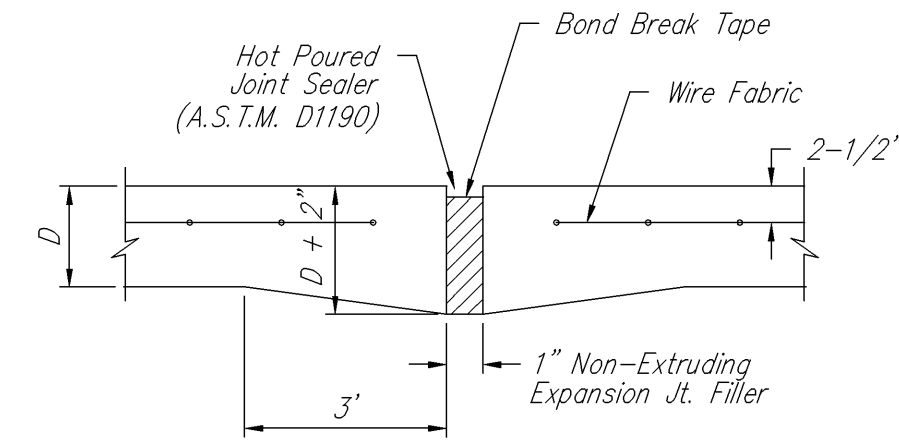

EXPANSION JOINT

NOTE: Extra Thickness to be Subsidiary to Price of Square Yards Pavement

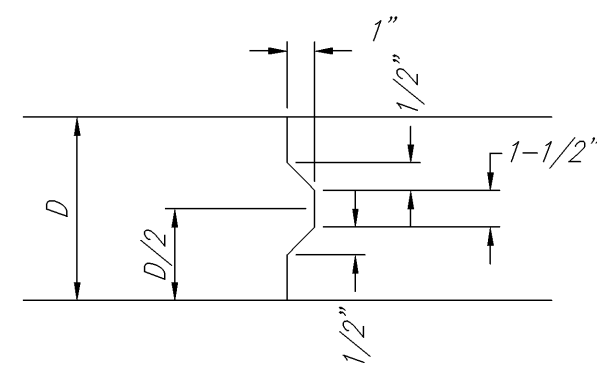

KEYWAY DETAIL

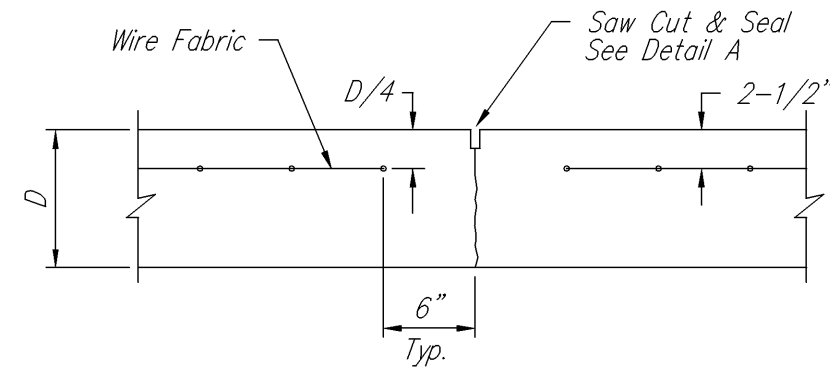

CONTRACTION JOINT DETAIL (C.J.)

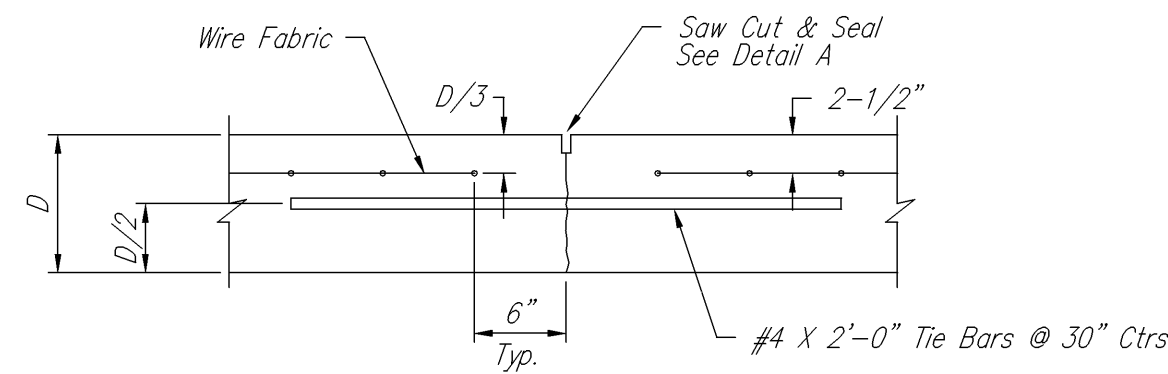

LONGITUDINAL JOINT DETAIL (L.J.)

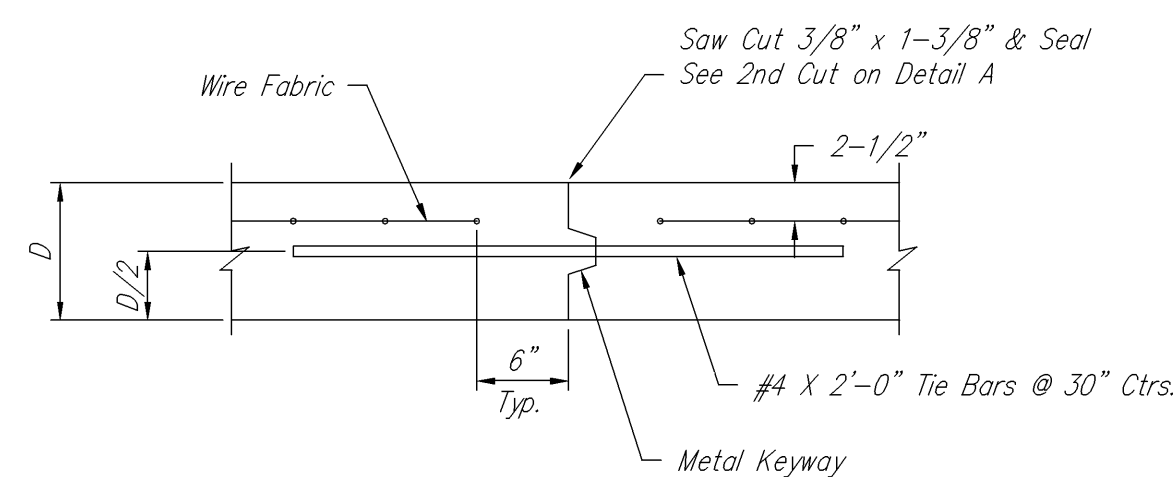

OPTIONAL LONGITUDINAL JOINT DETAIL (L.J.)

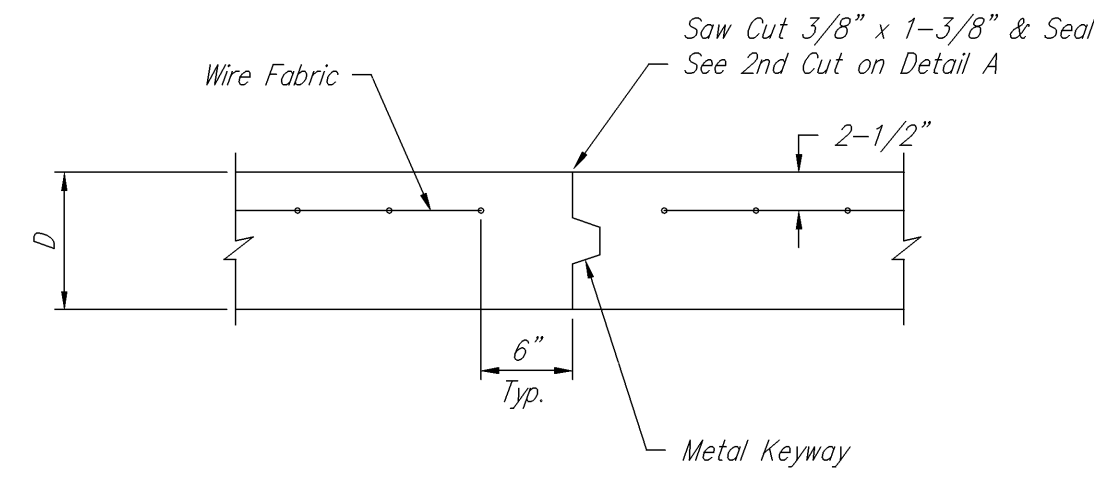

OPTIONAL CONTRACTION JOINT

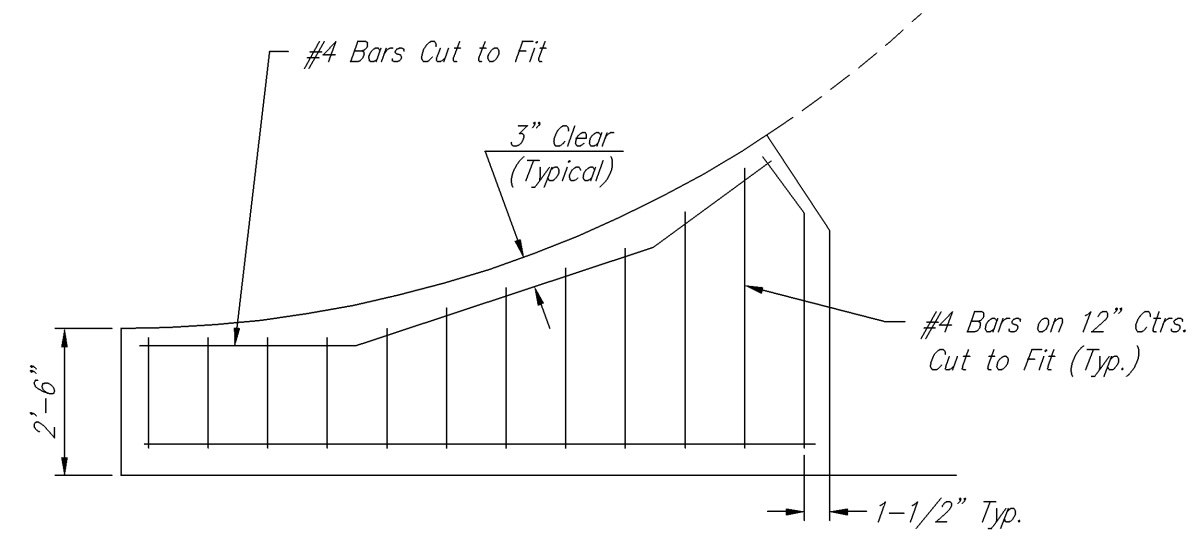

WING REINFORCING DETAIL

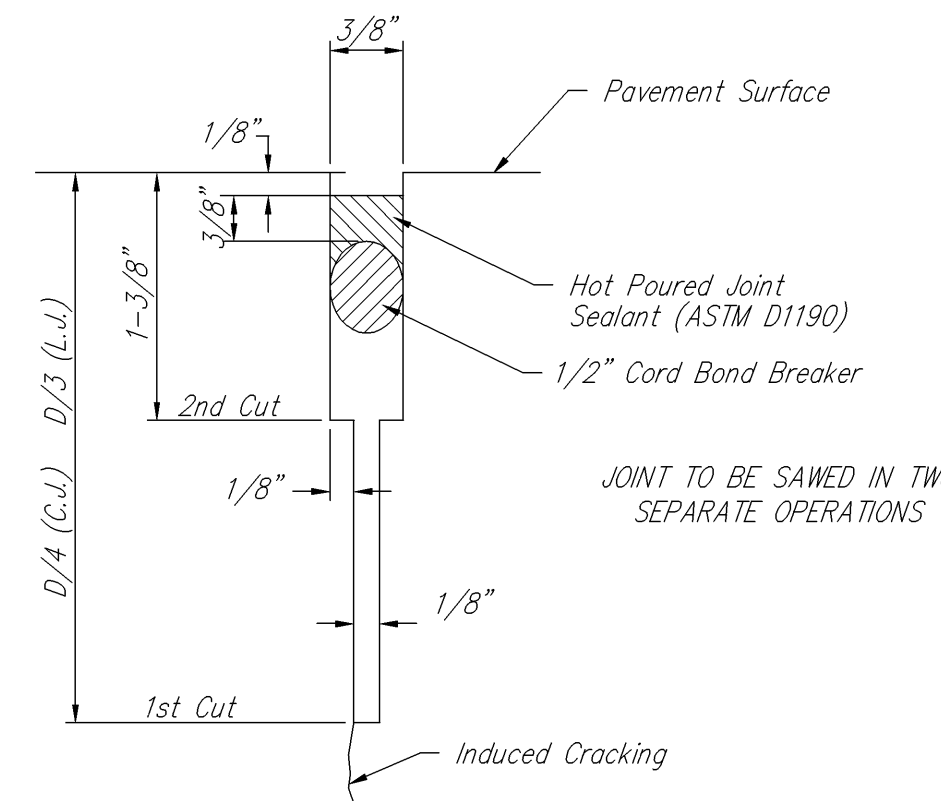

SAW JOINT DETAIL

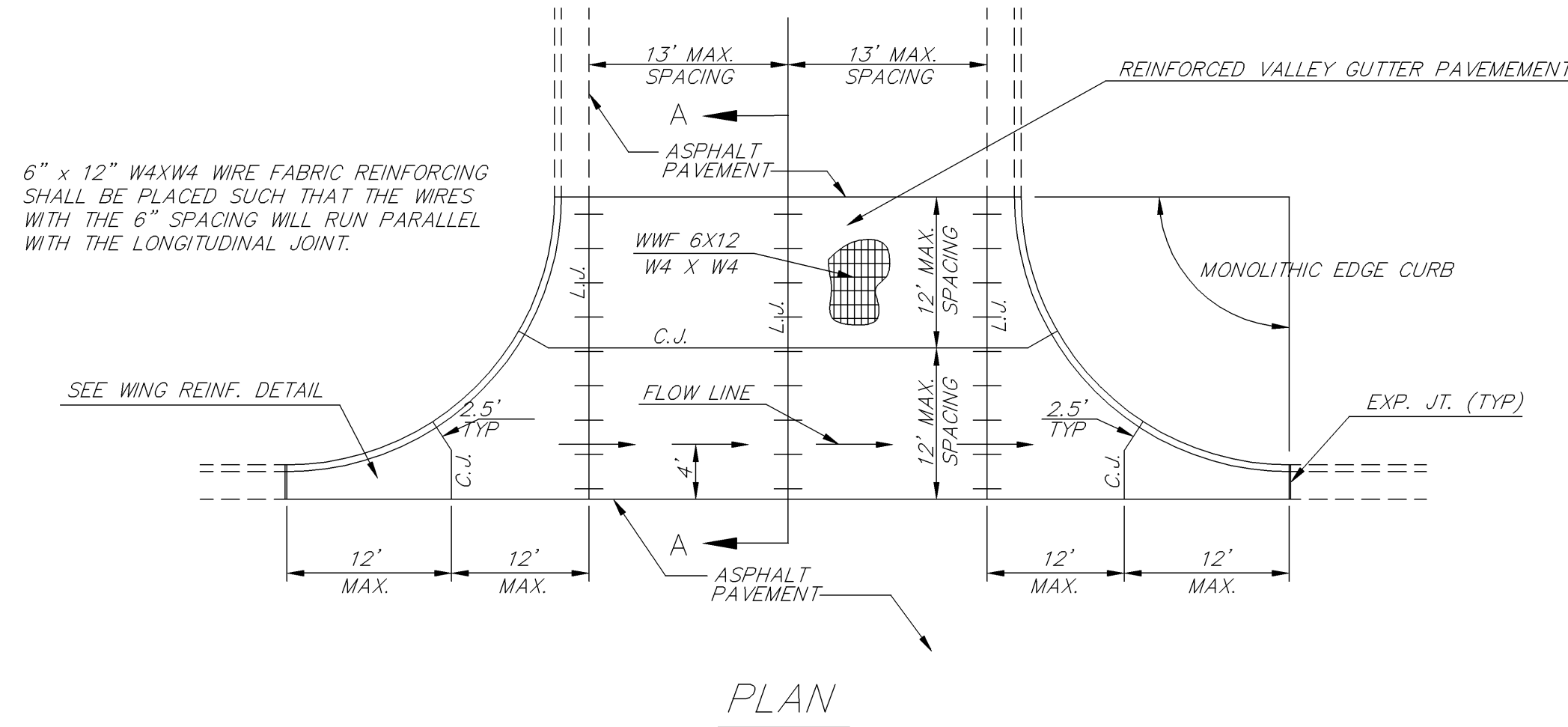

PLAN

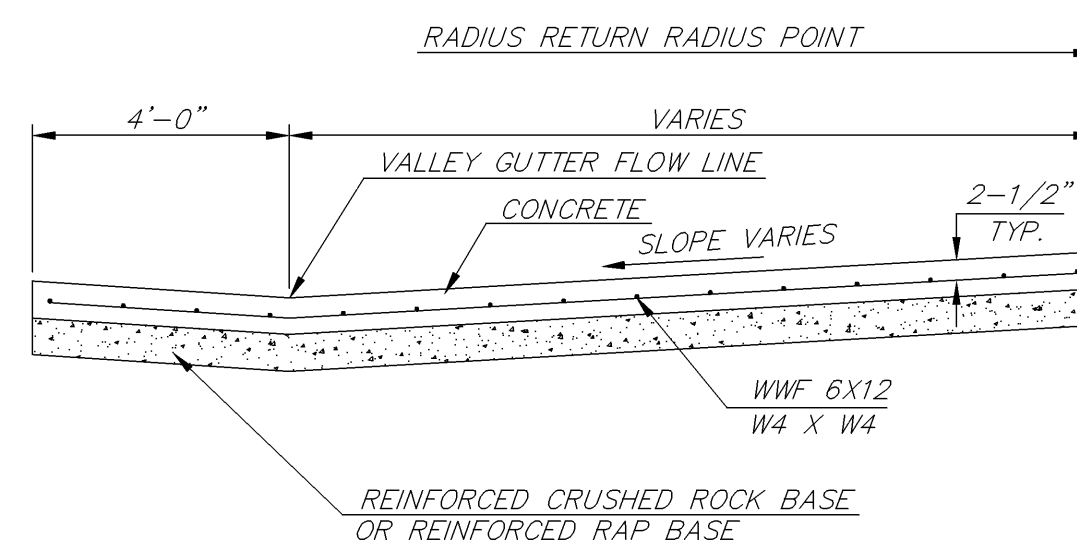

SECTION A-A

REINFORCED VALLEY GUTTER DETAIL

J:\2003Proj\03546\DWGS\Office Check Plans\20-Valygut.dwg 9/7/2005 3:59:30 PM CST

<p>THE CITY OF WICHITA CITY ENGINEER'S OFFICE 455 NORTH MAIN STREET WICHITA, KANSAS 67202 (316) 268-4501 (316) 268-4114 FAX</p>	<p>VALLEY GUTTER DETAILS</p>	
	<p>M. E. LINDEBAK P.E. - CITY ENGINEER</p>	
	<p>PROJECT NUMBER 472-83903</p>	<p>INDEX CODE XXXXXX</p>
	<p>DATE MAR 96</p>	<p>SHEET 20 OF 111</p>

VALYGUT.DWG