

PIPE SIZE	THRUST AT FITTINGS IN TONS-AT 150*/IN ² P					
	PLUG	90°	45°	1/2°	TEE	
6"	2.8	3.95	2.15	1.09	.55	2.8
8"	4.9	6.95	3.75	1.90	.96	4.9
12"	11.4	16.1	8.75	4.45	2.25	11.4
16"	20.15	28.5	15.4	7.85	3.95	20.15
20"	31.15	44.0	23.85	12.15	6.10	31.15
24"	44.55	63.0	34.1	17.4	8.75	44.55

TYPICAL THRUST BLOCKS

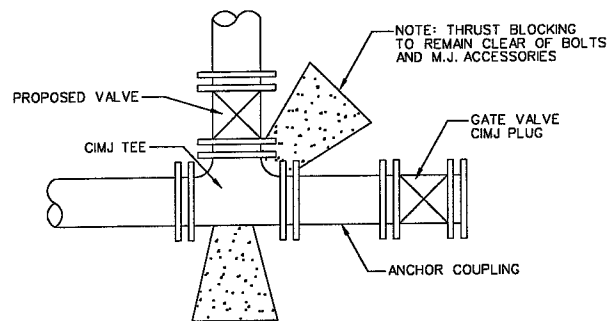

KEY BLOCK DETAIL

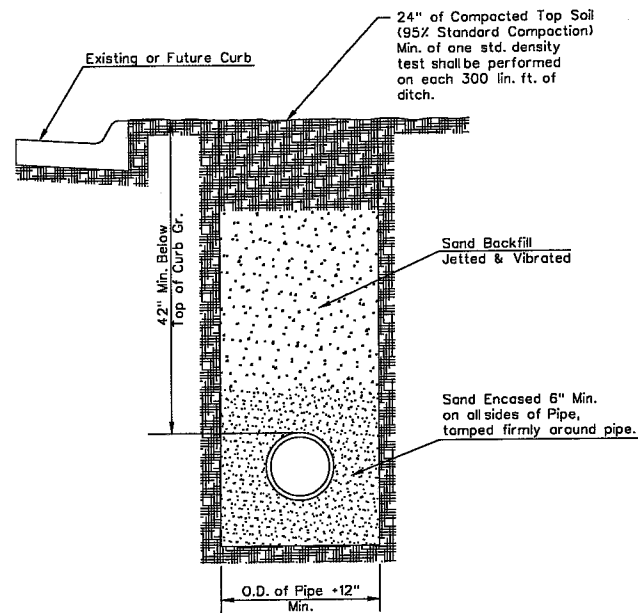

SETTLEMENT & COMPACTION ON CITY AND COUNTY ROAD RIGHT-OF-WAY EXCEPT UNDER PAVEMENT

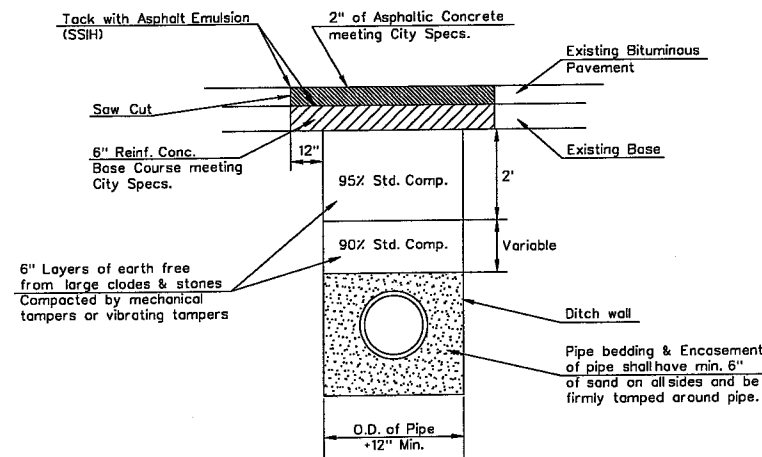

Standard Density Test, as described in the latest addition of ASTM D698, shall be performed to verify the above requirements to the Satisfaction of the Sedgwick County Director of Public Works. All testing cost shall be included in the unit price bid for the pipe in place.

When laying under paving, parallel with the centerline of the street, a minimum of one (1) Standard Density Test shall be performed on each 300 lineal feet of ditch.

PAVEMENT REPLACEMENT & DITCH COMPACTION UNDER EXISTING AND PROPOSED CITY ROADS

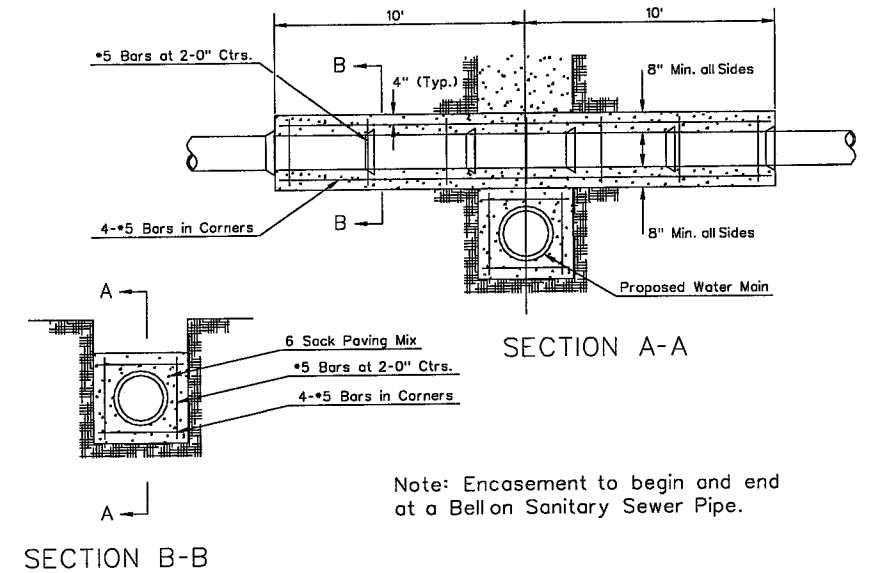

REINFORCED CONCRETE ENCASEMENT OF SANITARY SEWER

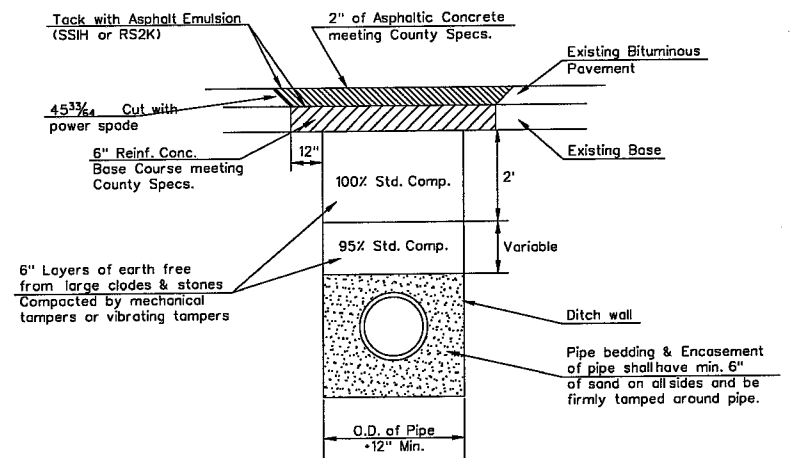

Standard Density Test, as described in the latest addition of ASTM D698, shall be performed to verify the above requirements to the Satisfaction of the Sedgwick County Director of Public Works. All testing cost shall be included in the unit price bid for the pipe in place.

When laying under paving, parallel with the centerline of the street, a minimum of one (1) Standard Density Test shall be performed on each 300 lineal feet of ditch.

PAVEMENT REPLACEMENT & DITCH COMPACTION UNDER EXISTING AND PROPOSED COUNTY ROADS

REVISED APR 97

<p>THE CITY OF WICHITA</p> <p>CITY ENGINEER'S OFFICE CITY HALL - SEVENTH FLOOR 435 NORTH MAIN STREET WICHITA, KANSAS 67202 (316) 268-4501 (316) 268-4114 FAX</p>	VARIOUS WATER DETAILS	
	JAMES L. ARMOUR P.E. - CITY ENGINEER	
	PROJECT NUMBER 472-84012	INDEX CODE XXXXXX
	DATE MAR 96	65