

E.F. INDICATES EACH FACE.  
N.F. INDICATES NEAR FACE.  
F.F. INDICATES FAR FACE.

STATE	PROJECT NO.	YEAR	SHEET NO.	TOTAL SHEETS
KANSAS	54-87 K-8258-08	2005	103	223

**GENERAL NOTES**

Fabricate the precast prestressed beams in accordance with the KDOT Standard Specifications. Submit shop drawings in accordance with the KDOT Standard Specifications except nine set are required. Use air entrained concrete. The KDOT Materials Section shall approve the mix design. Unless otherwise shown on the plans,  $f'c = 35$  MPa and  $f'c$  at release = 31 MPa. Use reinforcing steel conforming to the requirements of ASTM A615M-96, Grade 420. All reinforcing steel shall be epoxy coated. Use 13 mm nominal diameter, uncoated, seven wire, low relaxation prestressing tendons conforming to the requirements of ASTM A416, Grade 1860. Use coil ties and bolts having an ultimate strength 50% in excess of the manufacturer's safe load. The Engineer shall approve the coil ties. Coat coil ties that touch the prestressing tendons with an approved epoxy coating. Show coil tie details on the shop drawings. Coil ties and bolts shall be Subsidiary to the bid item "Prestressed Concrete Beams". Show on the shop drawings any hardware, holes or other appurtenances that are required to be incorporated into the girder to construct the girder or for any temporary works needed to construct the bridge (e.g. safety railing pockets). Use elastomeric bearing pads conforming to the KDOT Specifications. Bearing pads and Type B expansion joint material shall be Subsidiary to the bid item "Prestressed Concrete Beams". The beam lengths shown on the design plans are net lengths measured horizontally along the beam centerline. The beam manufacturer shall make necessary allowances for grade, and for shortening due to elastic shorting, creep and shrinkage. The beams shall reasonably conform to the lines and dimensions shown on the design plans and be within the tolerances specified in the latest publication of AASHTO "Tentative Standards for Prestressed Piles, Slab, I-Beams and Box Bridges and an Interim Manual for Inspection of Such Construction", except as modified by this sheet or the KDOT Specifications. Bevel all exposed edges of the beams except the tops and ends with a 20 mm triangular molding or round the edges to a 20 mm radius. Round the angle of intersection between the web and the flanges. Apply an initial force of 5 to 10 kN to each strand to take up any slack in the cables. Unless otherwise noted on the plans, apply a force of 138 kN to each strand. Stress the harped strands to a magnitude such that they are tensioned to 138 kN after they are in position. Strike off level and apply a wire brush or stiff broom finish to the tops of the beams. Apply the finish transverse to the length of the beam. (Note when using precast panels for deck construction, the outside 125 mm on each side of the top flange shall be finished smooth with a steel trowel.) At approximately the time of initial set, brush the top of the beam transversely with a course wire brush to remove all laitance. Fill trapped air holes and surface voids on the exterior face of exterior beams with an approved concrete masonry coating. This work shall conform to the KDOT Specifications. This work shall be Subsidiary to the bid item "Prestressed Concrete Beams". Detension strands in a sequence which minimizes lateral eccentricity. Show the method and sequence of the strand release on the shop drawings. Use extreme care when lifting, handling, storing and transporting beams. Use the lifting system shown or an alternate system approved by the Engineer. Keep the beam in an upright position at all times. Support the beam on bearing points positioned directly below the designated lifting points or designated bearing points. Do not place the bridge slab before the beams are 28 days old. Pour diaphragms as detailed in the bridge plans. Stencil with paint the following information on the webs approximately 1.5 m from one end of the beam: date of concrete placement, date of strand release, and beam mark.

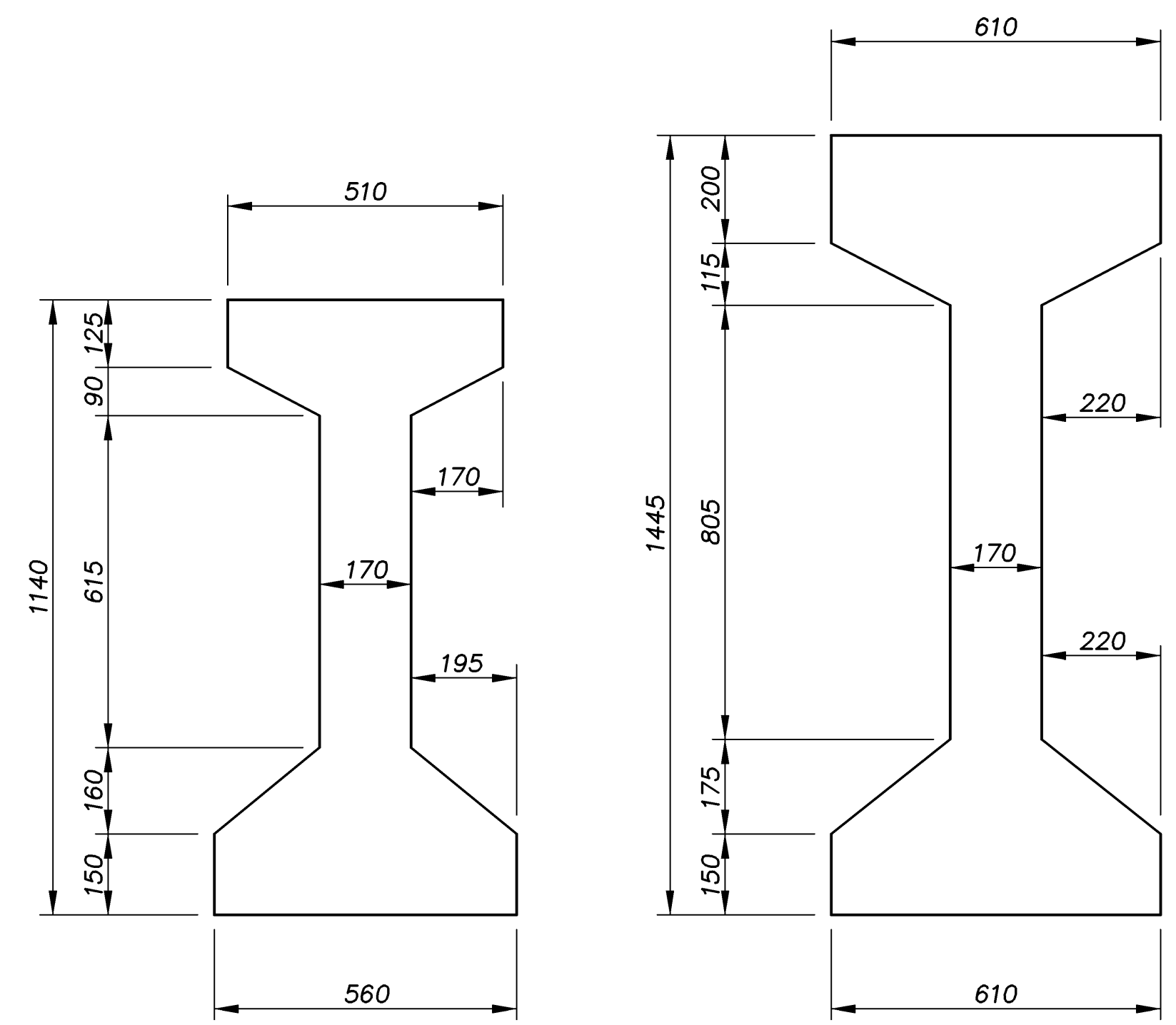

TYPE K3		TYPE K4+75 mm	
Area	341 300 mm <sup>2</sup>	Area	463 450 mm <sup>2</sup>
lcG	52 858x10 <sup>6</sup> mm <sup>4</sup>	lcG	121 075x10 <sup>6</sup> mm <sup>4</sup>
Y Bot	533 mm	Y Bot	732 mm
Vol./Surf Area	91 mm	Vol./Surf Area	101 mm
Mass/m	819 kg	Mass/m	1112 kg

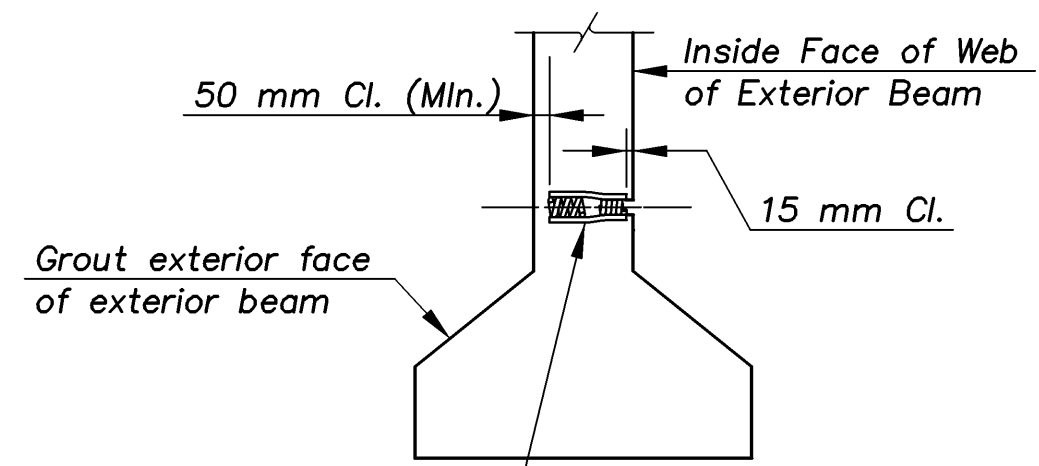

20 mm Open Coil Inserts  
(Safe Load Tension 25 kN) (3:1)

**COIL INSERT DETAIL**  
(See Beam Detail sheet for locations)

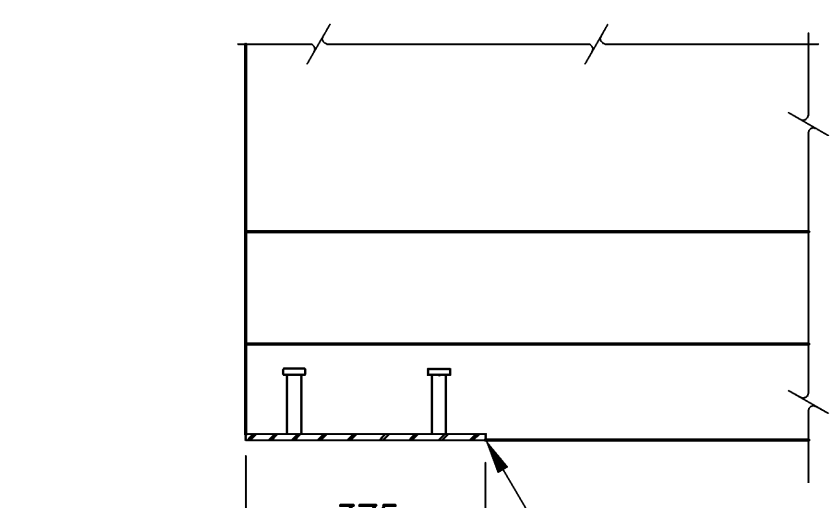

12 x 375 x 510 mm (K3)  
12 x 375 x 560 mm (K4+75 mm)  
(flush with btm. of beam)

**ELEVATION AT END OF BEAM**

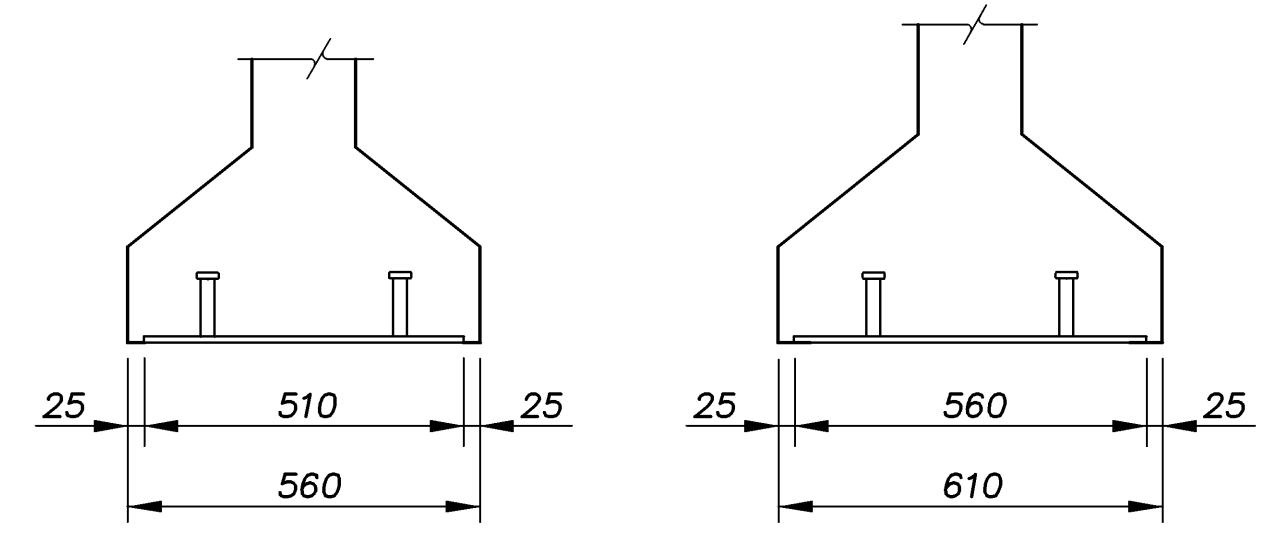

END VIEW (K3 Beam)  
END VIEW (K4+75 mm Beam)

NOTE: Stud welding will be in accordance with the latest edition of AWS D1.1. Use plates conforming to the requirements of ASTM A709M Grade 250. The stud anchors will be made of material as specified for Shear Connector Studs in the KDOT Standard Specifications. The exposed surfaces of the bearing plates shall be galvanized in accordance with the KDOT Standard Specifications. All work and material necessary to install the bearing plates shall be Subsidiary to the bid item "Prestressed Concrete Beams".

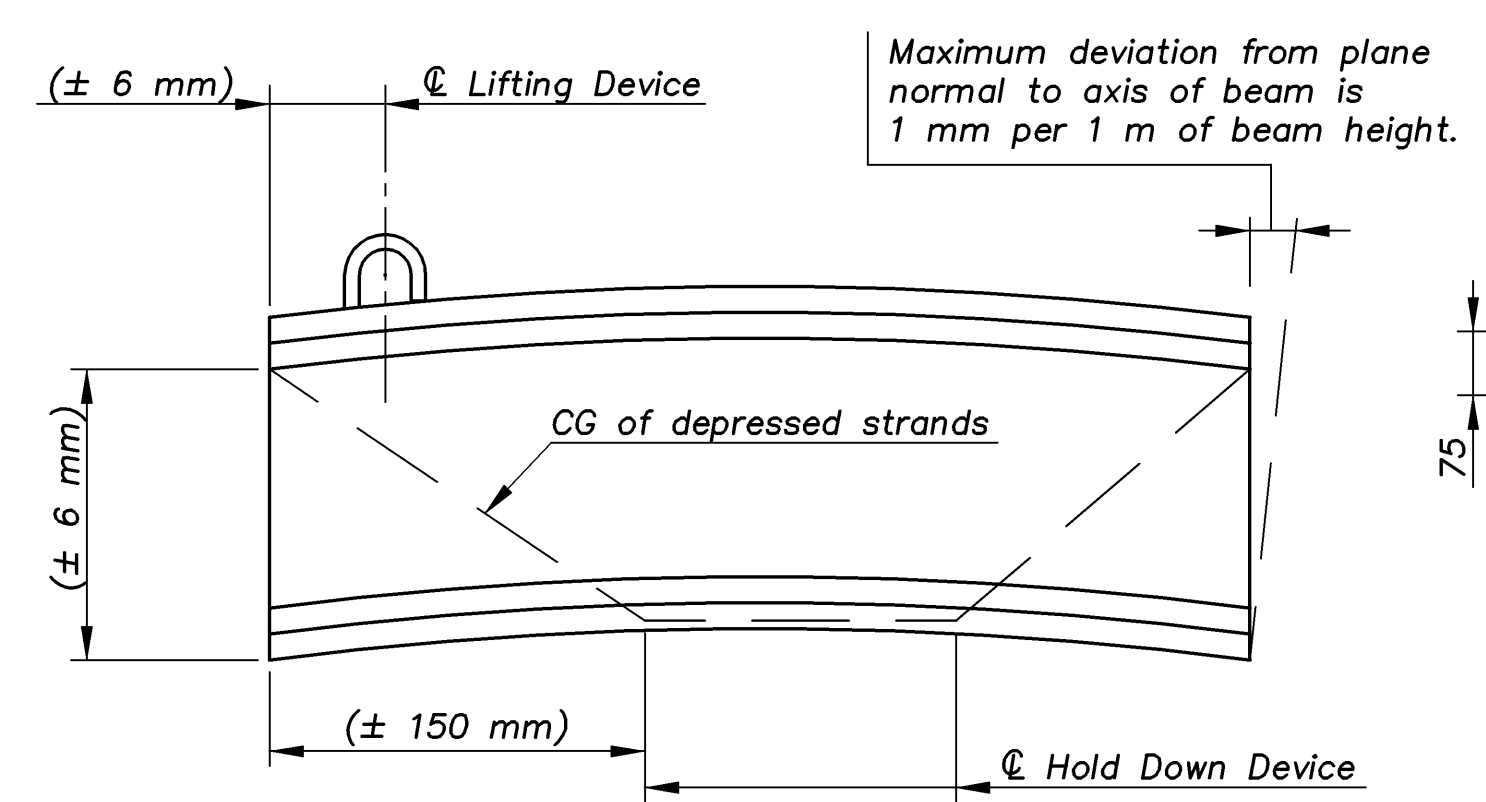

**BEAM ELEVATION**

CG = Center of Gravity

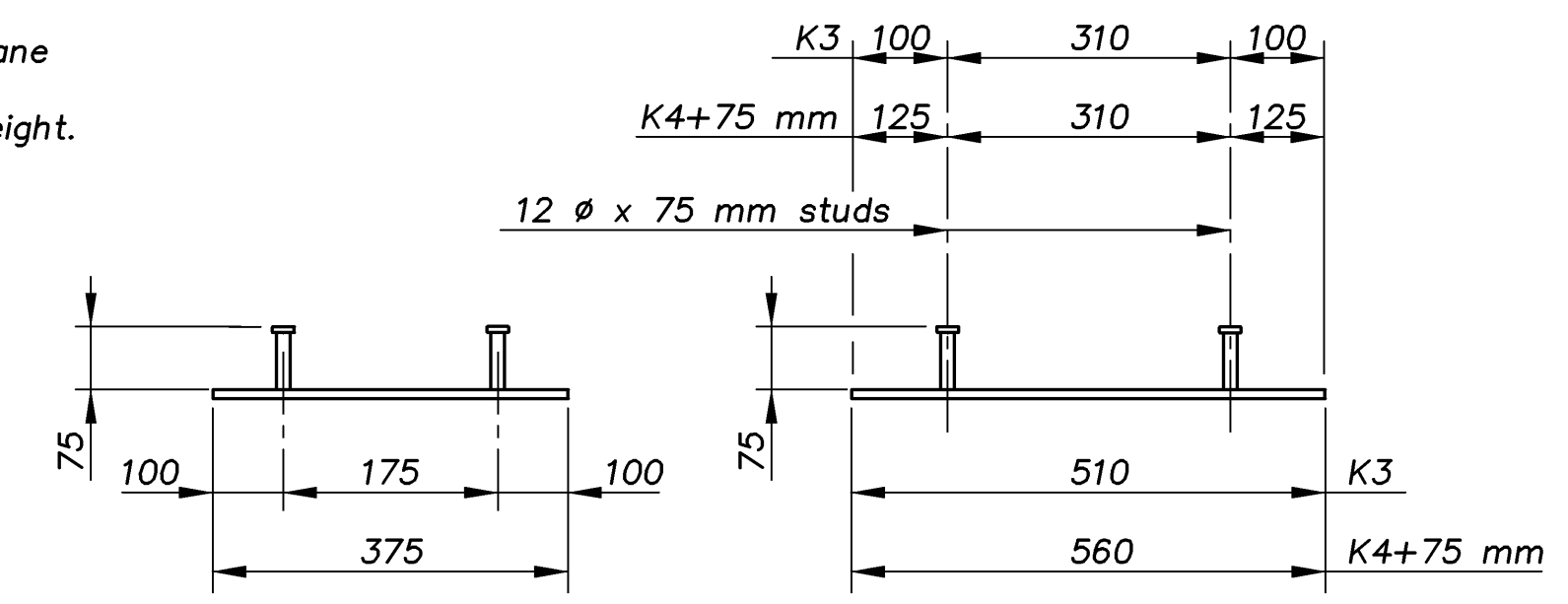

ELEVATION SECTION

**BEARING PLATE DETAILS**

NOTE: Dimensions shown in parentheses are tolerances only.

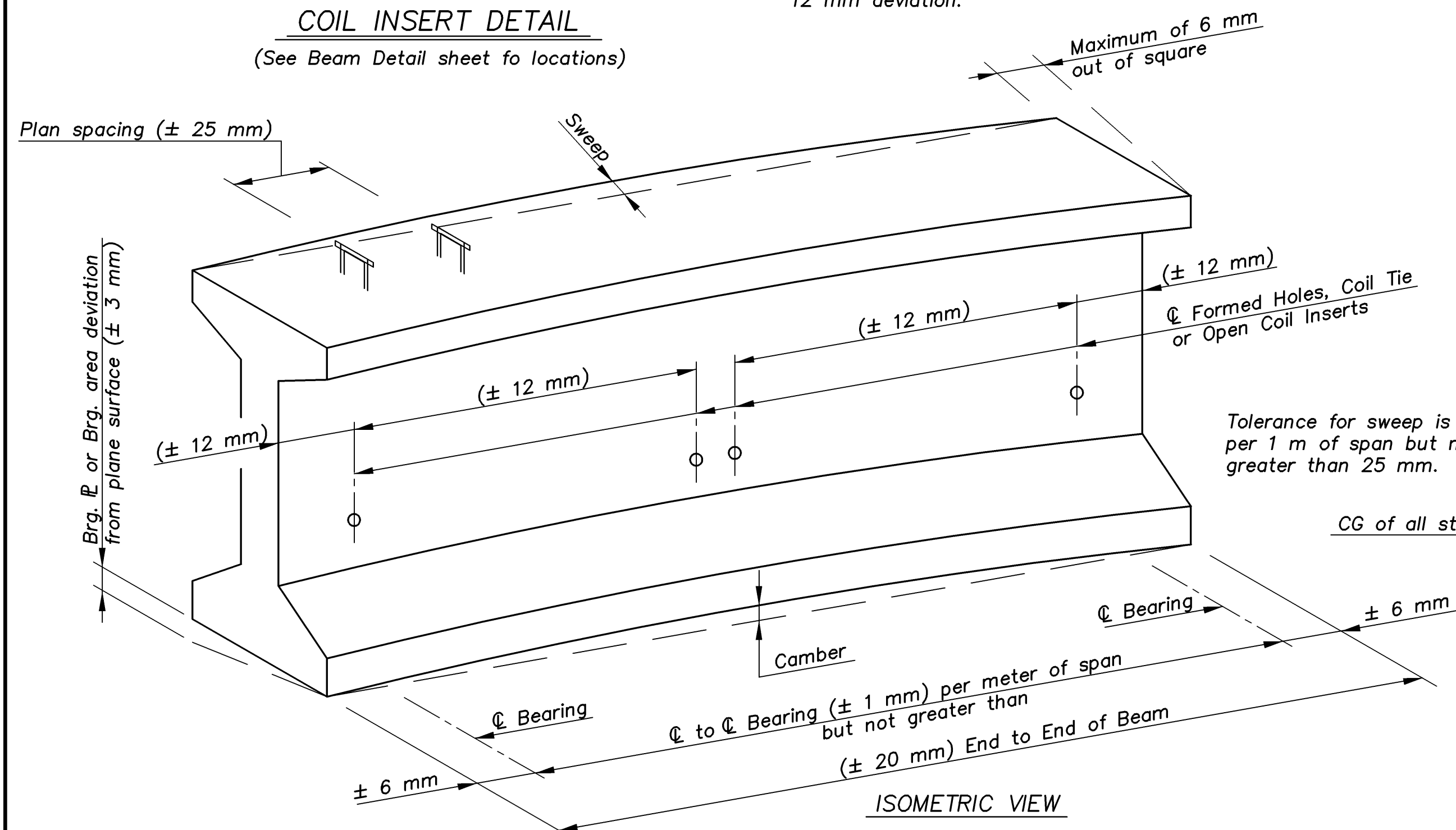

NOTE: Tolerance for camber is 25 mm maximum variation in camber between adjacent beams, and 1 mm per meter of span deviation from the specified camber but not greater than 12 mm deviation.

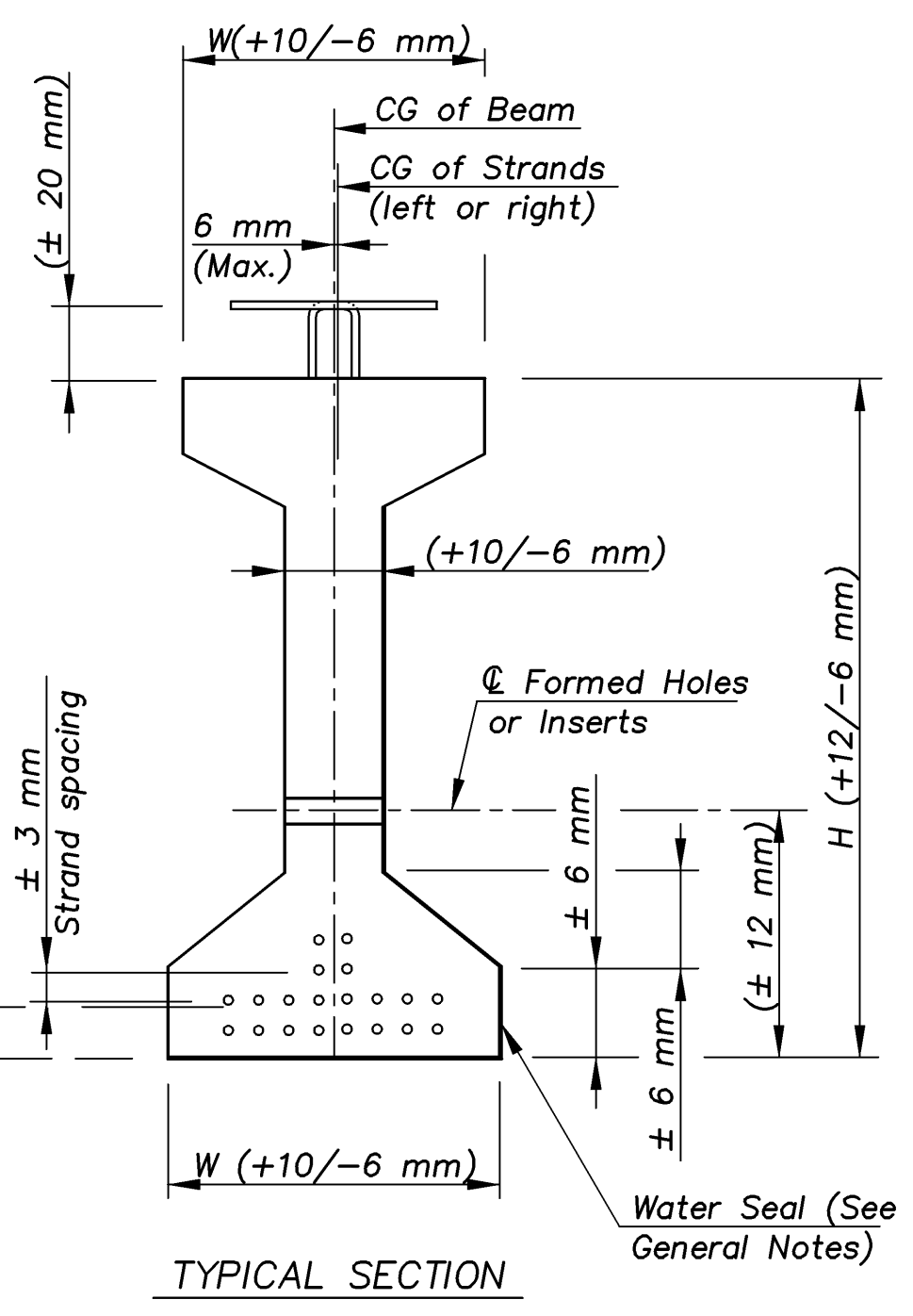

**TYPICAL SECTION**

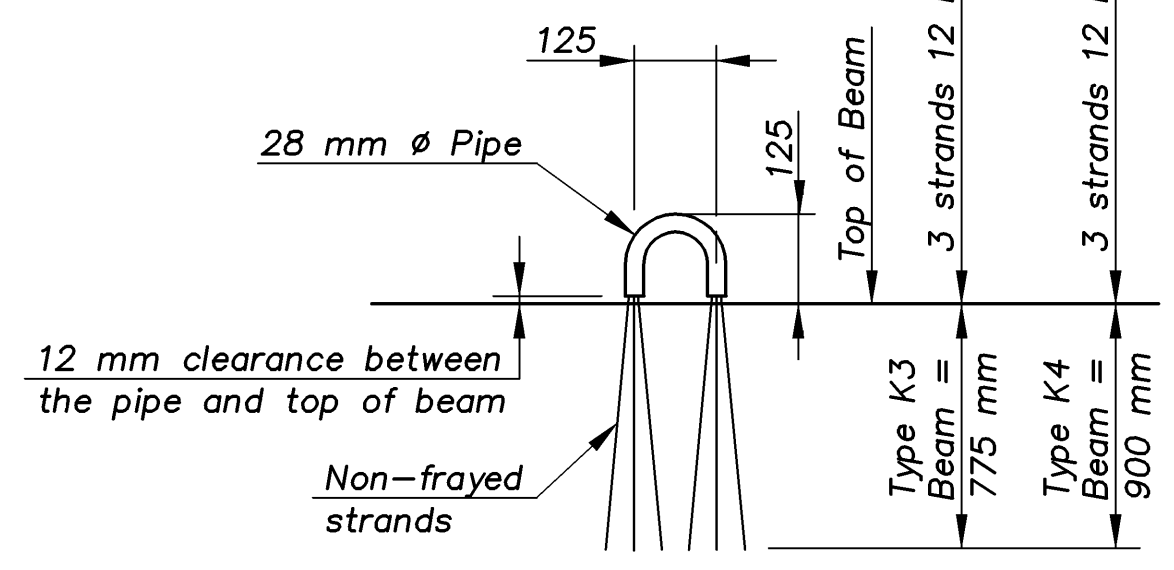

**LIFTING DEVICE DETAIL**

**PRESTRESSED BEAM FABRICATION TOLERANCES**

KANSAS DEPARTMENT OF TRANSPORTATION  
BR. NO. 54-87-31.55(704) W.B. STA. 4+575.138  
BR. NO. 54-87-31.56(705) E.B.  
**STANDARD P.C. BEAM DETAILS**  
KELLOGG AVENUE OVER EASTERN  
Proj. No. 54-87 K-8258-08 SEDGWICK COUNTY

**CFS**  
Cook, Flatt & Strobel  
ENGINEERS, P. A.  
DESIGNED R.S.C. SCALE Varies  
DETAILED T.R.G. DATE  
QUANTITIES T.R.G. SHEET 25 OF 47