

WOVEN WIRE TYPE B FENCE  
NOT TO SCALE

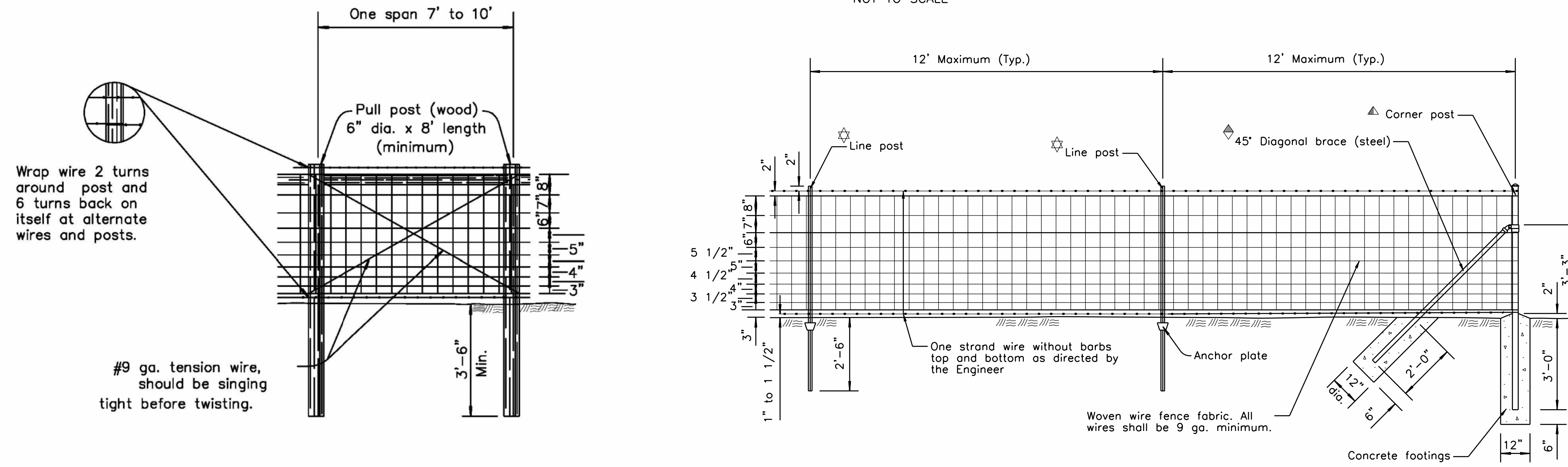

GENERAL NOTES

- Wood posts and braces shall be given a preservative treatment as provided in the Standard Specifications.
- Both ends of all wood posts shall be cut normal to the axis of the post. Pointed posts will not be permitted.
- Wood corner, end, pull and approach posts shall be notched to support ends of wood braces. Wood braces shall be toenailed to the posts with 2-10d nails in each end of the brace.
- When wood posts are used, both ends of all tension wires shall be wrapped around the posts twice and stapled in place.
- When wood posts are used the fence shall be grounded by a 5/8" diameter galvanized or copper coated rod five feet long, driven vertically until the top is six inches below the ground surface. A #6 solid copper conductor shall be securely fastened to each element of the fence by use of clamps or other suitable device. Grounding rod shall be installed at intervals of 175' maximum. In lieu of using the galvanized or copper coated rod as described above the contractor may, at his option, use a steel line post at intervals not to exceed each eighth post.
- The galvanized or copper coated rod shall be used where power lines pass over the fence.
- All steel posts, braces, fittings, and gate frames shall be galvanized and/or coated.
- Steel posts shall be provided with fasteners to prevent slippage of the wire strands.
- Outside diameters shown for tubular steel posts, bracing and gate frames are nominal.
- Posts may be set by driving or digging. If by digging, the posts shall be set in the center of the hole and the soil tamped securely on all sides.
- Pull post assembly shall be used at sharp breaks in vertical grade or at approximately 330' centers on straight runs or as directed by the Engineer.
- Concrete used in fence installation shall conform to the requirements of the City Standard Specifications. Barbed wire and tension wire shall be either zinc coated (galvanized) or aluminum coated.
- Minimum strength of tension wire shall be as provided in the Standard Specifications.
- Woven wire and tension wire shall be either zinc coated (galvanized) or aluminum coated.
- Use #9 gauge galvanized staples 1 1/2" to 1 3/4" long, or #9 gauge galvanized Ring-shank staples 1 1/2" to 1 3/4" long.
- Alternate gate designs may be submitted for approval. Lighter weight materials will not be approved.
- Padlocks for gates shall be furnished by the City.

(STEEL)

- Steel line post 7'-0" length
  - Studded T (1.33#/lin. ft.)
  - U (1.33#/lin. ft.)
  - H (2.27#/lin. ft.)
- 1 3/4" Oval back I-beam (2.43#/lin. ft.)
- Brace
  - 1.660" O.D., 0.083" Th. (1.40#/lin. ft.) pipe (Group 1C) or
  - 1.660" O.D., 0.140" Th. (2.27#/lin. ft.) pipe (Group 1A) or
  - 1 3/4" Oval Back I-Beam (2.45#/lin. ft.) or
  - 1 5/8"x1 3/4" Brace rail (See Alt. Details)
- End, corner, gate, or pull post 7'-6" length.
  - (A120) 2.875" O.D., 0.203" Th. (5.97#/lin. ft.) pipe (Group 1A) or
  - 2.875" O.D., 0.160" Th. (4.64#/lin. ft.) pipe (Group 1C) or
  - 2 1/4" Oval Back I-Beam (3.65#/lin. ft.) or
  - 3 1/2"x3 1/2" Type II (4.85#/lin. ft.)

TYPICAL LEVEE RESURFACING DETAILS

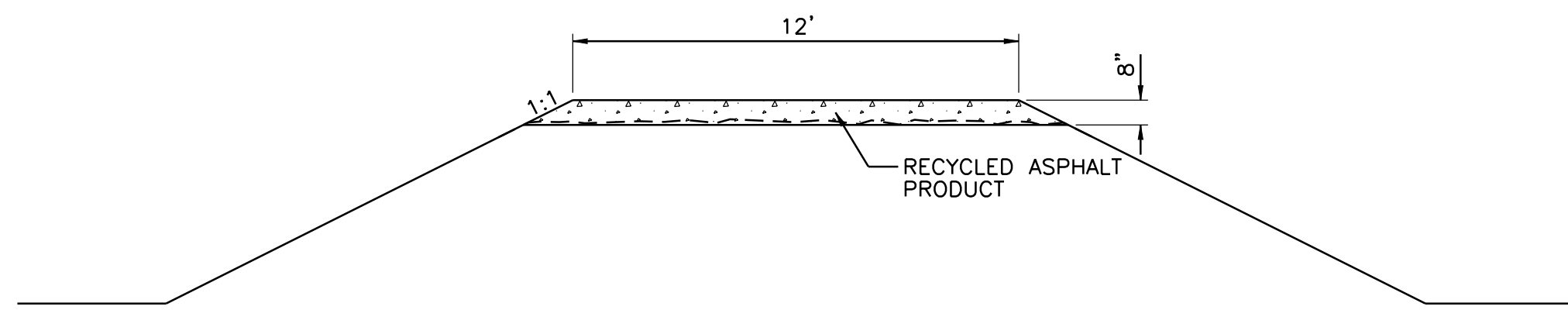

LEVEE SURFACING DETAIL 1  
FOR RESURFACING ONLY

NOTE:  
UPON COMPLETION OF ALL TREE REMOVAL ACTIVITY, THE TOP OF THE LEVEE SHALL BE RESURFACED WITH RECYCLED ASPHALT PRODUCT (MINIMUM 8-INCH THICK COMPACTED LAYER). REFER TO LM SHEETS FOR RESURFACING LOCATIONS.

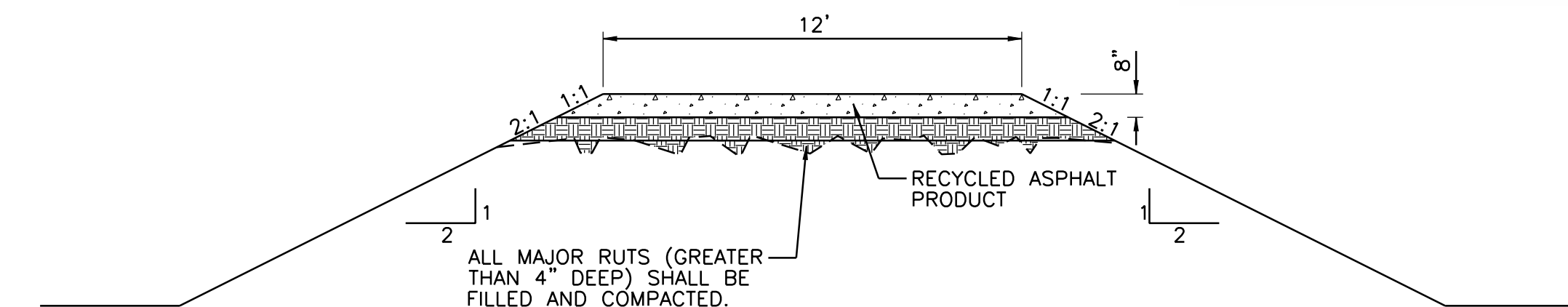

LEVEE SURFACING DETAIL 3  
FOR LEVEES THAT ARE TO BE RAISED MORE THAN 0.6'

NOTE:  
UPON COMPLETION OF ALL TREE REMOVAL ACTIVITY, ALL MAJOR RUTS (GREATER THAN 4-INCHES DEEP) SHALL BE FILLED AND COMPACTED IN ACCORDANCE WITH SHEET G-1.02. ONCE RUTS HAVE BEEN FILLED, THE TOP OF THE LEVEE SHALL BE RAISED TO 8-INCHES BELOW THE ELEVATION SPECIFIED ON THE DRAWINGS WITH COMPACTED FILL ON 2:1 SIDE SLOPES. UPON COMPLETION OF THE COMPACTED FILL, AN 8-INCH THICK LAYER OF RECYCLED ASPHALT PRODUCT SHALL BE APPLIED, COMPACTED AND GRADED TO A SMOOTH SURFACE. THE RESURFACED TOP OF LEVEE ELEVATIONS SHALL BE AT OR ABOVE THE FINISHED GRADE ELEVATION SPECIFIED ON THE DRAWINGS. REFER TO LM SHEETS FOR RESURFACING LOCATIONS AND RESURFACING ELEVATIONS FOR INDIVIDUAL LEVEE SEGMENTS.

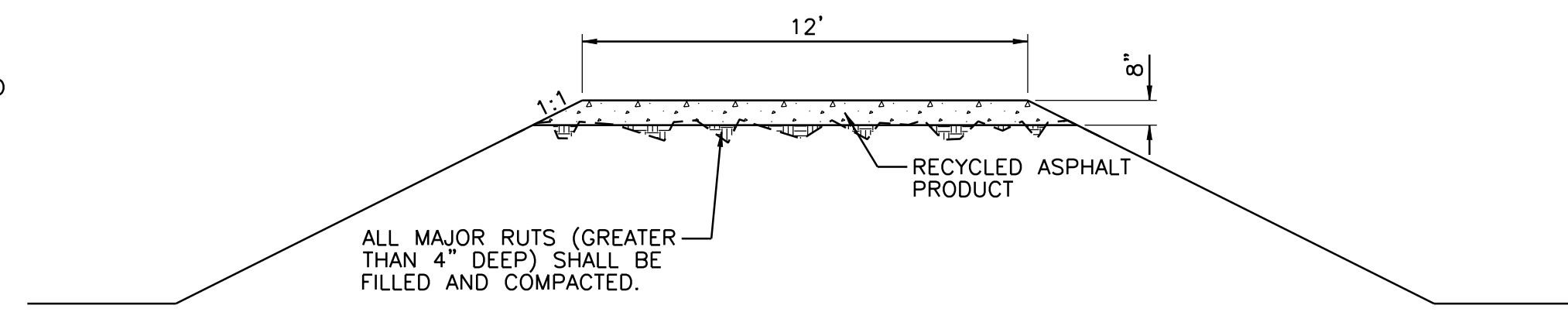

LEVEE SURFACING DETAIL 2  
FOR LEVEES THAT ARE TO BE RAISED 0.6' OR LESS.

NOTE:  
UPON COMPLETION OF ALL TREE REMOVAL ACTIVITY, ALL MAJOR RUTS (GREATER THAN 4-INCHES DEEP) SHALL BE FILLED AND COMPACTED IN ACCORDANCE WITH SHEET G-1.02. ONCE RUTS HAVE BEEN FILLED, THE TOP OF THE LEVEE SHALL BE GRADED AND AN 8-INCH THICK LAYER OF RECYCLED ASPHALT PRODUCT SHALL BE APPLIED, COMPACTED AND GRADED TO A SMOOTH SURFACE. THE RESURFACED TOP OF LEVEE ELEVATIONS SHALL BE AT OR ABOVE THE ELEVATION SPECIFIED ON THE DRAWINGS. REFER TO LM SHEETS FOR RESURFACING LOCATIONS AND RESURFACING ELEVATIONS FOR INDIVIDUAL LEVEE SEGMENTS.

MARK	DESCRIPTION	DATE	APPR

**amec**  
AMEC Earth & Environmental, Inc.  
1129 SW Winemaker  
Topeka, Kansas 66604  
Phone: (785) 272-6830  
Fax: (785) 272-6878



SYSTEMWIDE VEGETATION MAINTENANCE - PHASE 1  
WICHITA-VALLEY CENTER LOCAL  
FLOOD PROTECTION PROJECT  
WICHITA, KANSAS

PREPARED FOR  
THE CITY OF WICHITA, KANSAS  
465 N. Main  
Wichita, KS 67202

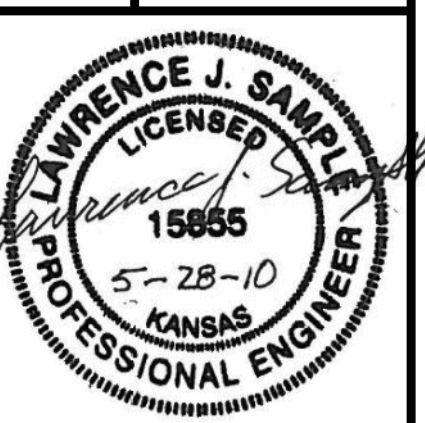

DESIGNED BY: Larry Sample, PE	DATE: 5-28-2010
DWN BY: DSM	CKD BY: LBK
APP BY: L. SAMPLE	
FILE NAME: 561500000-GI-104.dgn	
AMEC PROJ. NO. 5-6150-0000	
FENCE AND LEVEE SURFACING DETAILS	
G-1.04	
SHEET 5 OF 38	