

Note to Designer: This F3 Barrier Anchorage at Expansion Joint is only for use on bridges with thermal expansion of 1/2" or greater at the recommendation and review of Bridge Designer. Bridges longer than 1,000 feet require a Special Design.

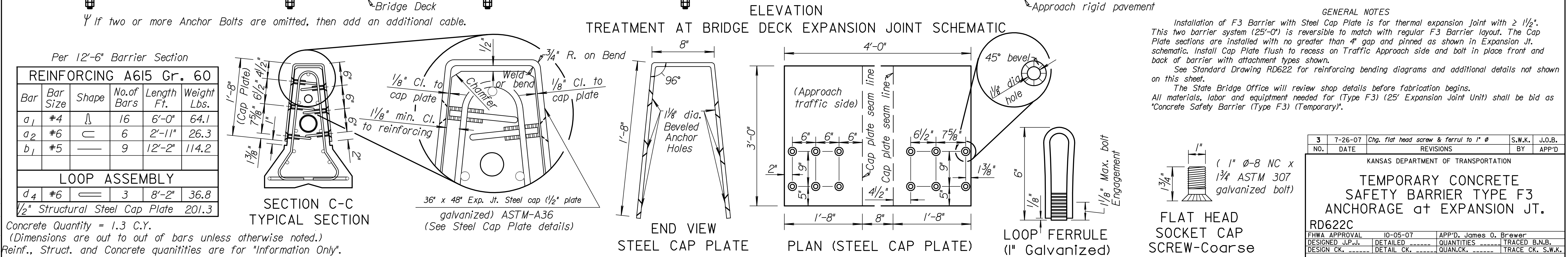
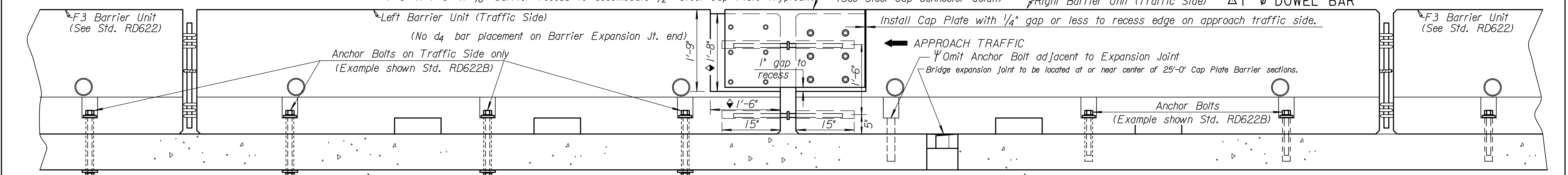
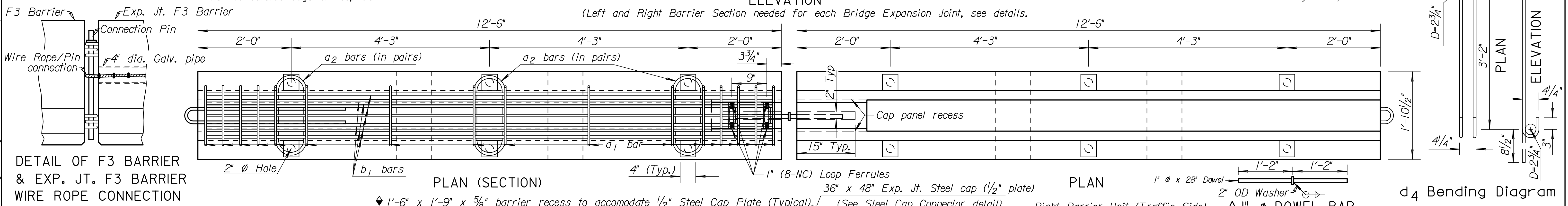
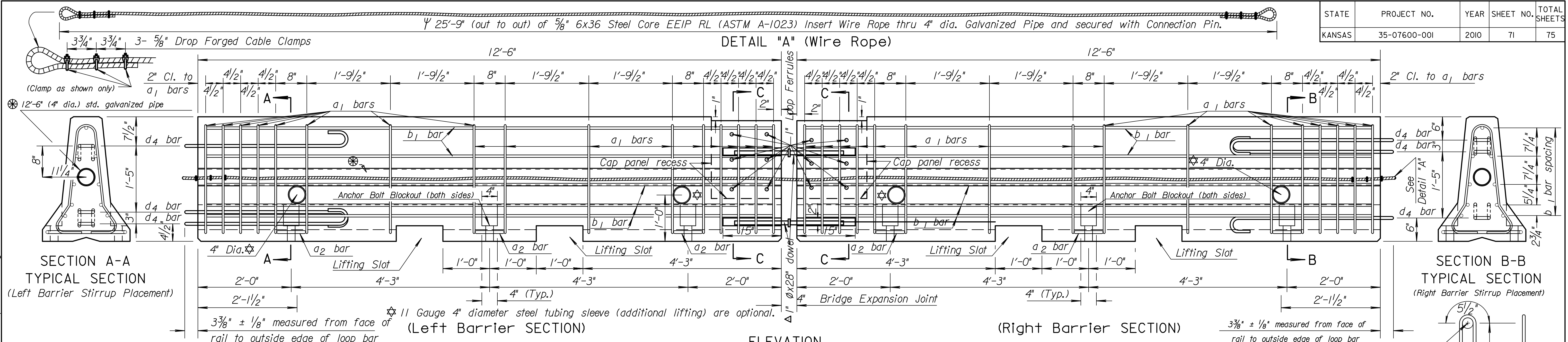

Scaled 03-08-2010 10:35:06 AM by CSI  
 Plot Scale 1:1 03-09-2010 4:46:13 PM by CSI  
 03/2007/07600/001/Phase 2/07600-001-C-Traffic Details rd622c