

POND 2
 STATIC POOL = 1315.0
 100yr WS = 1317.0
 Pond Bottom = 1308.0
 100yr Qin = 55.6 cfs
 100yr Qout = 54.8 cfs

POND GRADING SECTION

Point Table			
Point #	Northing	Easting	Description
9047	17681.24	17778.78	POND
9048	17605.56	17776.45	POND
9049	17507.47	17781.11	POND
9050	17439.04	17805.83	POND
9051	17467.35	17883.21	POND
9052	17556.52	17849.05	POND
9053	17647.89	17809.10	POND
9054	17655.68	17750.93	POND
9055	17439.93	17866.98	POND
9056	17451.38	17769.36	POND
9057	17686.99	17740.66	POND
9058	17665.58	17730.65	POND
9059	17630.60	17738.44	POND
9060	17595.06	17757.76	POND
9061	17549.91	17766.42	POND
9062	17502.02	17758.51	POND
9063	17451.03	17748.20	POND
9064	17418.85	17778.54	POND
9065	17415.02	17827.15	POND
9066	17416.37	17854.54	POND
9067	17427.06	17893.53	POND
9068	17464.16	17904.32	POND
9069	17522.58	17899.20	POND
9070	17573.44	17862.76	POND
9071	17639.58	17835.95	POND

Point Table			
Point #	Northing	Easting	Description
9072	17668.65	17821.15	POND
9073	17702.46	17777.69	POND
9074	17716.21	17764.52	POND
9075	17691.70	17824.13	POND
9076	17641.74	17851.40	POND
9077	17594.04	17870.05	POND
9078	17543.59	17905.93	POND
9079	17479.17	17918.80	POND
9080	17422.72	17909.85	POND
9081	17400.15	17867.21	POND
9082	17398.53	17813.95	POND
9083	17411.71	17755.82	POND
9084	17459.93	17734.31	POND
9085	17527.36	17748.28	POND
9086	17595.00	17741.53	POND
9087	17653.43	17715.33	POND
9088	17697.46	17730.51	POND
9130	17398.33	17811.59	CENTERLINE WEIR
9131	17398.85	17869.58	CENTERLINE WEIR

Point Table			
Point #	Northing	Easting	Description
9252	17373.50	17838.30	Geogrid
9253	17373.49	17875.02	Geogrid
9254	17336.72	17903.88	Geogrid
9255	17336.73	17867.17	Geogrid

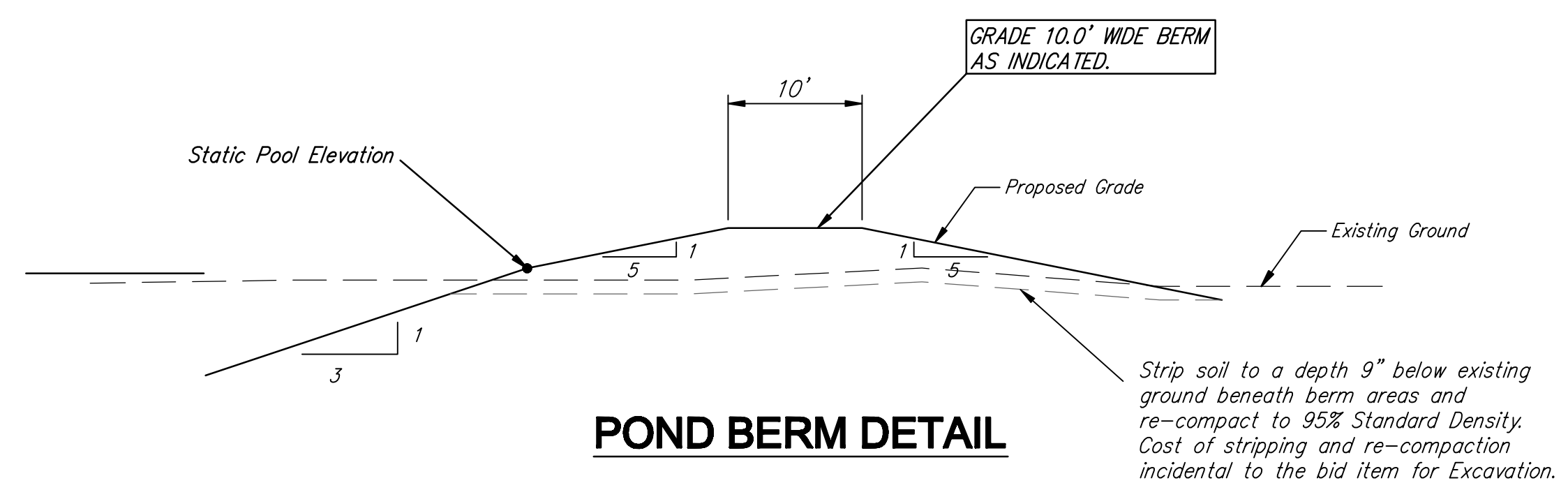

POND BERM DETAIL

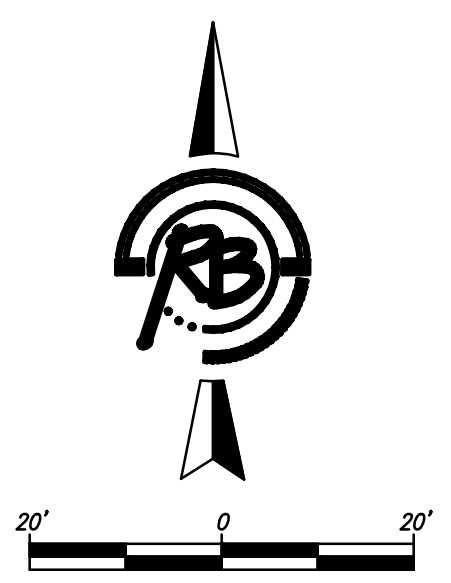

**Sierra Hills 2nd Addition
 POND 2
 WICHITA, KANSAS**

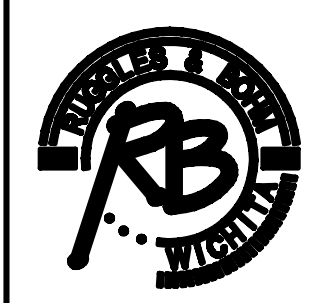

Ruggles & Bohm, P.A.
 Engineering, Surveying, Land Planning

824 North Main
 Wichita, Kansas 67203
 www.rbo.com

(316) 264-8800
 (316) 264-8811 fax
 E-mail: info@rbo.com

DESIGNER: E.J.G.
 CHECKED: E.J.G.
 DRAWN: E.J.G.
 DATE: April 30, 2009
 UTILITY

3 OF 23

DATE: ---