

(Min. 16 Perforations Per Lin. Ft. @ 1/4" Dia.)
Perforations To Be on Bottom Half

SECTION A-A

CRUSHED ROCK UNDERDRAIN AGGREGATE GRADATION REQUIREMENTS

Percent of Aggregate Retained	
1 1/2"	0
3/4"	15-60
# 4	40-80
#40	74-92
P-200	4-12

Rock quality shall be the same as specified for coarse aggregate for asphalt concrete mixes.

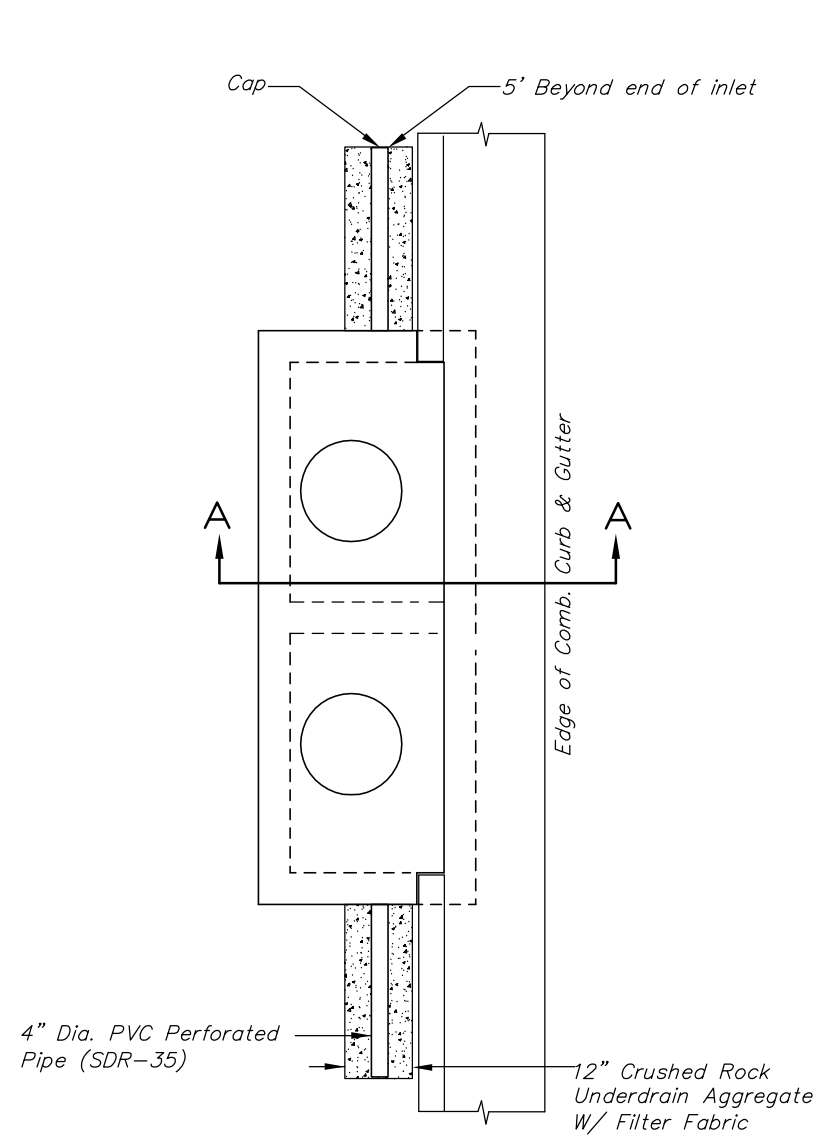

TYPE 1 AND 2 INLET

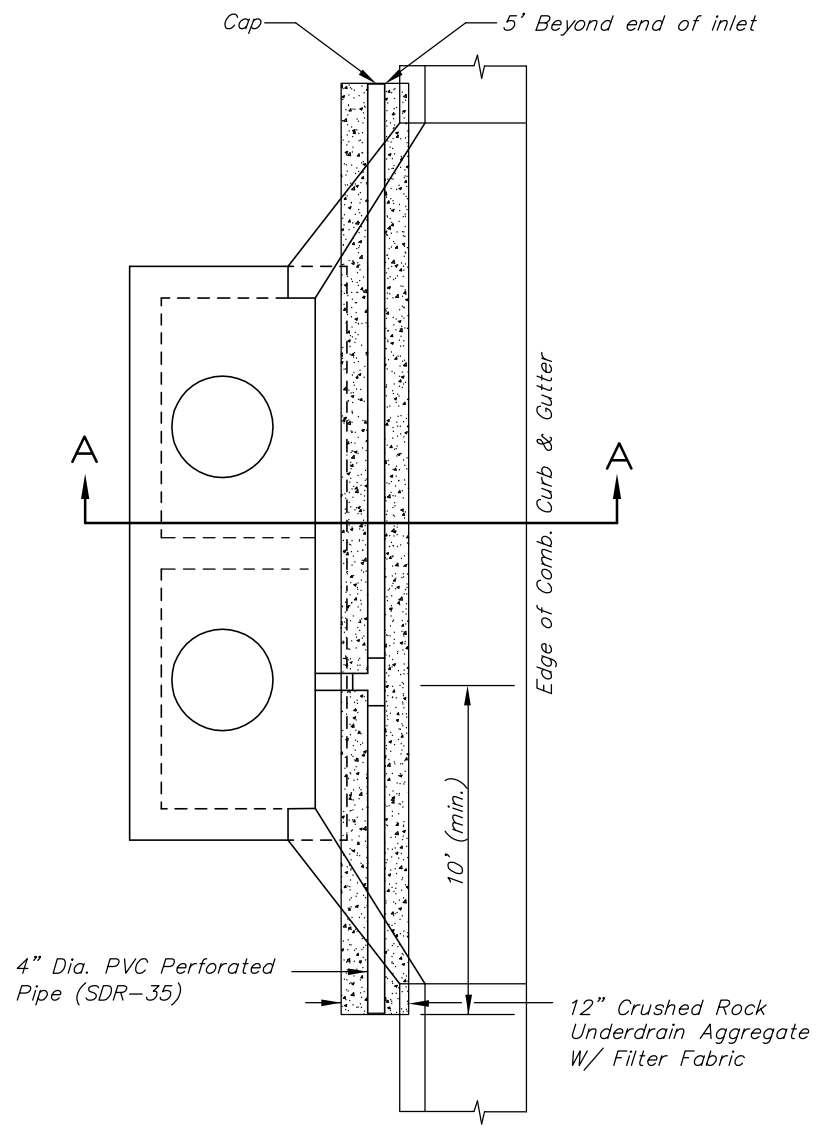

TYPE 1-A INLET

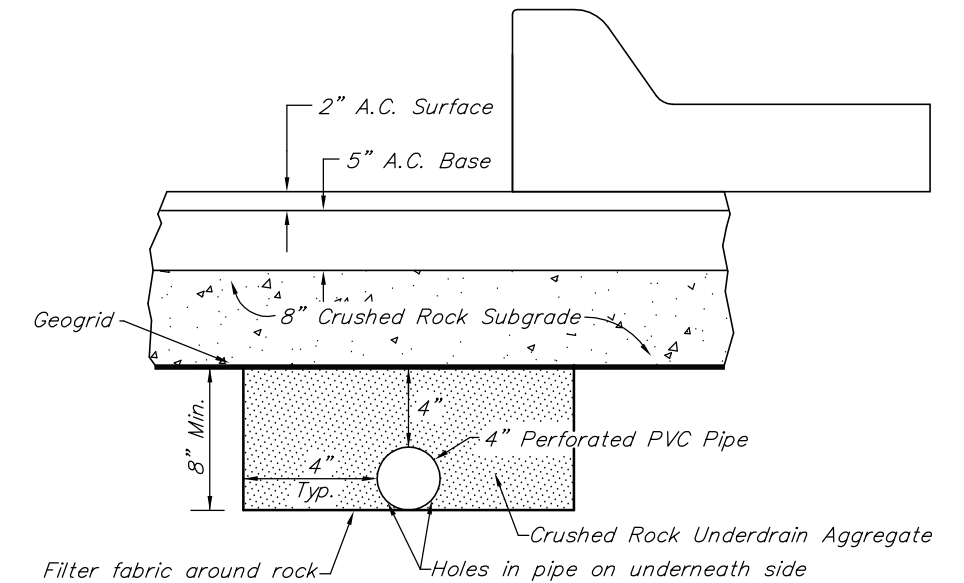

PAVEMENT UNDERDRAIN AT SUMPS

NOTE:
Place 4" PVC Perforated Pipe at all drainage sump locations.

Cost of Underdrain System at sumps to be incidental to the Reinforced Crushed Rock Subgrade.

Refer to "Pipe Connection Detail" on Sheet No. 47 for connections to structures.

J:\Civil\04222\dwg\Details\UNDERDRAIN.dwg 2/25/2005 2:25:24 PM CST

KANSAS DEPARTMENT OF TRANSPORTATION
**PAVEMENT UNDERDRAIN
DETAIL**
PROJECT NO. 87 N-0235-01 SEDGWICK CO.
M K E C ENGINEERING CONSULTANTS, INC.
WICHITA, KANSAS

DESIGNED BY: JRA	CHECKED BY: JRA
DRAWN BY: WNJ	DATE: JULY 2004 SHEET 37 OF 120