

**NOTE:**

SPECIAL FINISH FOR TRAFFIC SIGNAL STRUCTURES: ALL EXTERIOR SURFACES ARE COATED WITH A ZINC RICH EPOXY POWDER TO A MINIMUM DRY FILM THICKNESS OF 2.0 MILS. THE COATING IS ELECTROSTATICALLY APPLIED AND PARTIALLY CURED IN A GAS FIRED CONVECTION OVEN BY HEATING THE STEEL SUBSTRATE TO A MINIMUM OF 250 DEGREES FAHRENHEIT.

THE POWDER PRIMED SURFACE IS COATED WITH AN INTERMEDIATE COAT OF POLYESTER POWDER TO A MINIMUM DRY FILM THICKNESS OF 2.0 MILS. THE COATING IS ELECTROSTATICALLY APPLIED AND CURED BY HEATING THE SUBSTRATE IN A CONVECTION OVEN TO A MINIMUM OF 350 DEGREES AND A MAXIMUM OF 400 DEGREES FAHRENHEIT.

THE INTERMEDIATE COAT IS TOP COATED WITH ONE COAT OF HIGH-BUILD ACRYLIC POLYURETHANE ENAMEL TO A MINIMUM DRY FILM THICKNESS OF 2.0 MILS. THE COATING IS ELECTROSTATICALLY APPLIED AND CURED BY HEATING THE SUBSTRATE IN A CONVECTION OVEN TO A MINIMUM OF 225 DEGREES FAHRENHEIT. THE FINAL TOP COATING COLOR SHALL BE BLACK.

THE COLOR OF EXTERIOR SURFACE OF ALL STRUCTURES, POLES, SIGNAL HEADS, BRACKETS, EQUIPMENT, CABINETS, COVERS, PANELS AND COMPONENTS SHALL BE MATCHING BLACK, UNLESS OTHERWISE NOTED.

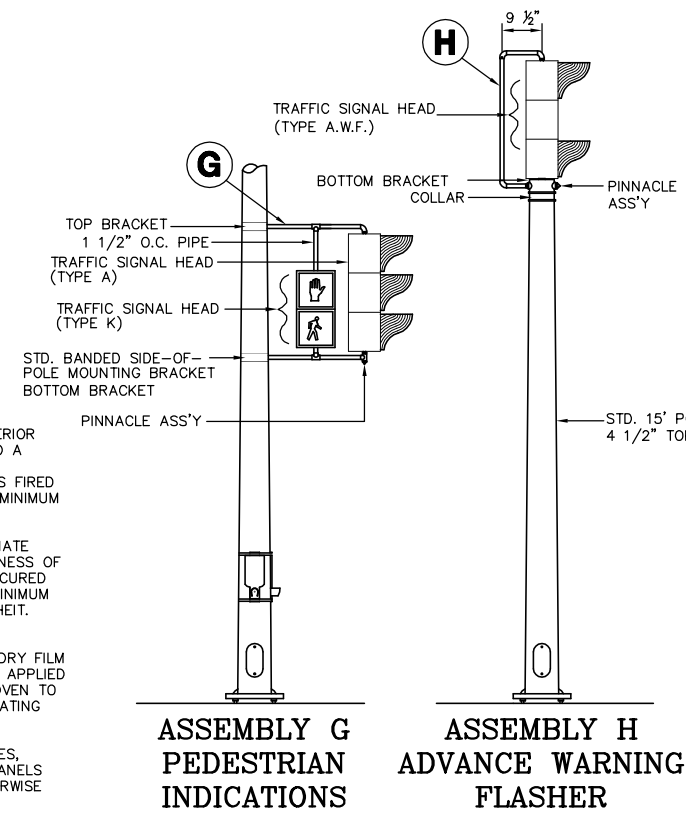
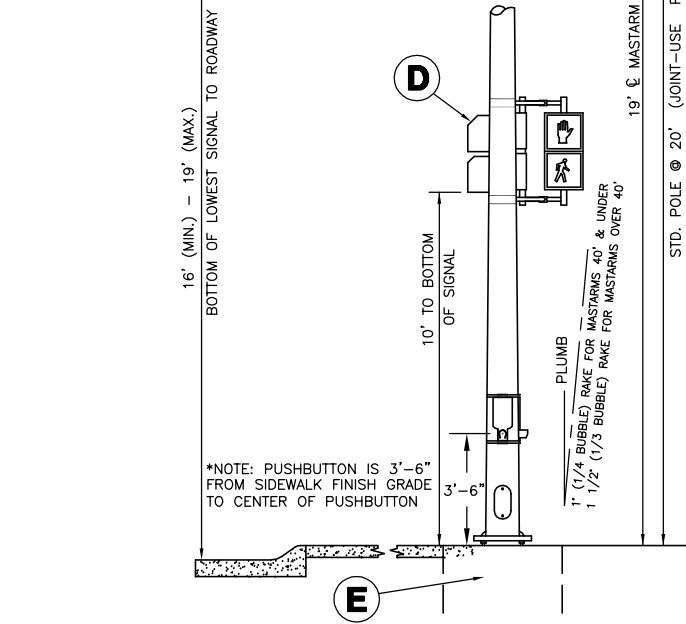

**BANDED SIGN MOUNTING BRACKET DETAIL**

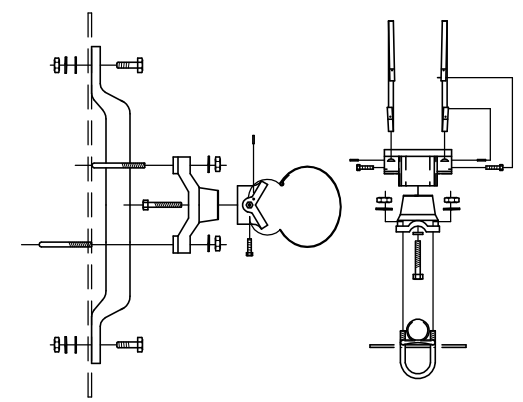

**TYPE I SIGNAL MOUNTING BRACKET ASSEMBLY DETAIL**

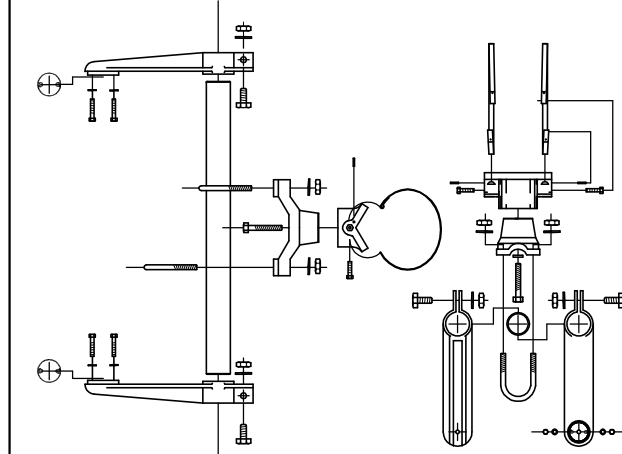

**STANDARD SIGNING**



**TYPE III SIDE-OF-POLE MOUNTING BRACKET ASSEMBLY**

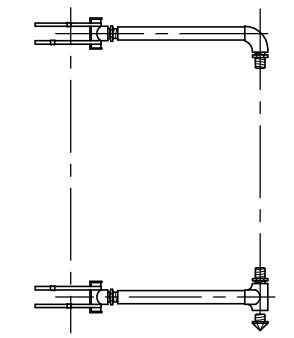

**TYPE IV 12" PEDESTRIAN INDICATIONS ASSEMBLY**

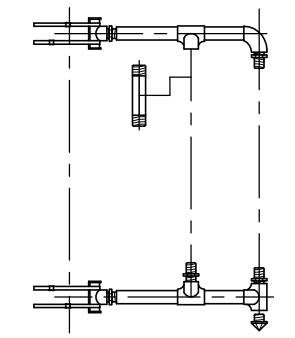

**TYPE V ADVANCE WARNING FLASHER ASSEMBLY**

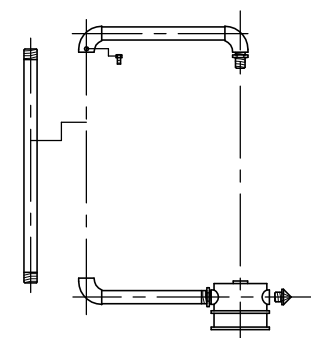

**TYPE II SIDE-OF-POLE SIGNAL MOUNTING BRACKET ASSEMBLY**

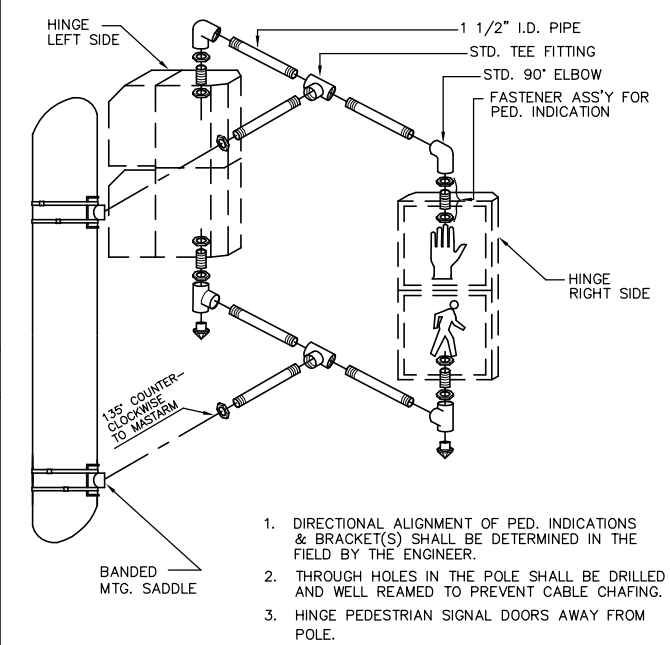

1. DIRECTIONAL ALIGNMENT OF PED. INDICATIONS & BRACKET(S) SHALL BE DETERMINED IN THE FIELD BY THE ENGINEER.
2. THROUGH HOLES IN THE POLE SHALL BE DRILLED AND WELL REAMED TO PREVENT CABLE CHAFING.
3. HINGE PEDESTRIAN SIGNAL DOORS AWAY FROM POLE.

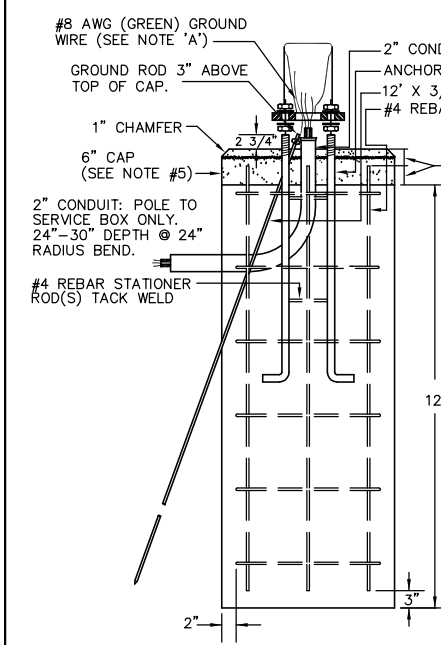
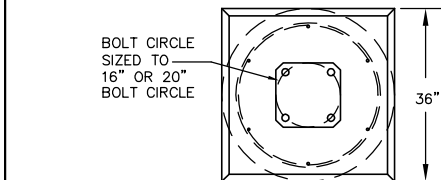

- NOTE: "A"**  
A SINGLE CONDUCTOR STRANDED #8 GREEN WIRE SHALL CARRY THE EQUIP. GROUND FROM THE GROUND LUG OF ALL SIGNAL POLES TO THE CONTROLLER CABINET AND THE POWER DISCONNECT BOX. WHEN NECESSARY EQUIP. GROUND CAN BE SPLICED IN SERVICE BOX WITH SPLIT BOLT CONNECTOR.
- NOTE:**
1. THE ANCHOR BOLTS FOR THE SIGNAL POLE SHALL BE TACK WELDED TOGETHER IN A 16" OR 20" DIA. BOLT PATTERN (ON CENTERS AS SHOWN) TO MAINTAIN REQUIRED BOLT CONFIGURATION PATTERN AND TO AID IN VERTICAL POSITIONING WHILE CONCRETE BASE IS POURED.
  2. USE ANTI-SEIZE COMPOUND ON ALL THREADS.
  3. 12" x 3/4" GROUND ROD TO BE POSITIONED BEFORE POURING BASE.
  4. CLASS 'A' CONCRETE SHALL BE USED TO CONSTRUCT BASE.
  5. CONSTRUCT A 6" THICK x 36" SQUARE CONCRETE CAP AFTER POLE HAS BEEN ERECTED & PLUMBED. CHAMFER EDGE 1". MUST BE APPROVED BY ENG. BEFORE POURED.
  6. CONDUIT SHALL HAVE PLASTIC (OR METAL) BUSHING (ABOVE BASE) TO PREVENT CABLE CHAFING.
  7. USE #6 BARE COPPER GROUND CONDUCTOR FROM CLAMP TO GROUND BOLT IN ACCESS HOLE.

**REBAR CAGE**

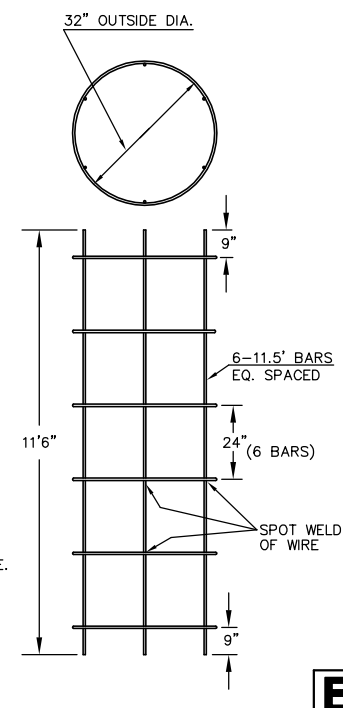

J:\Civil\04222\dwg\signals\SSP-DTL.DWG 7/21/2005 4:20:09 PM CST

PROJECT DESCRIPTION		
STEEL SIGNAL POLE ASSEMBLY DETAILS		
PROJECT NUMBER 472-83540		
DRAWN BY: T.M.	APPROVED BY:	REVISED BY: T.M.
DATE: FEB. 96		DATE: MAY, 97
CITY OF WICHITA DEPARTMENT OF PUBLIC WORKS		
DIVISION OF TRAFFIC ENGINEERING	SCALE	77/120
PAUL GUNZELMAN P.E. TRAFFIC ENGINEER	NO SCALE	SHEET / OF