

EXPANSION JOINT

NOTE: Extra Thickness to be Subsidiary to Price of Square Yards Pavement

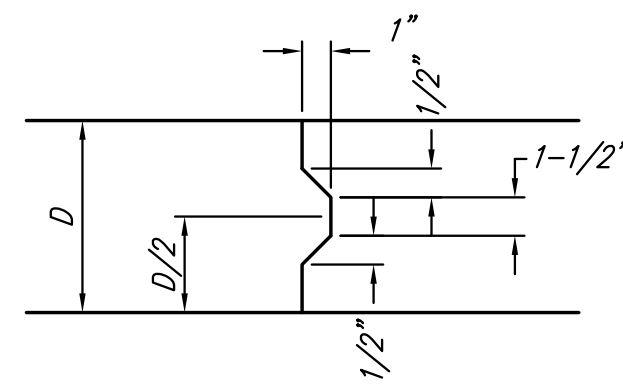

KEYWAY DETAIL

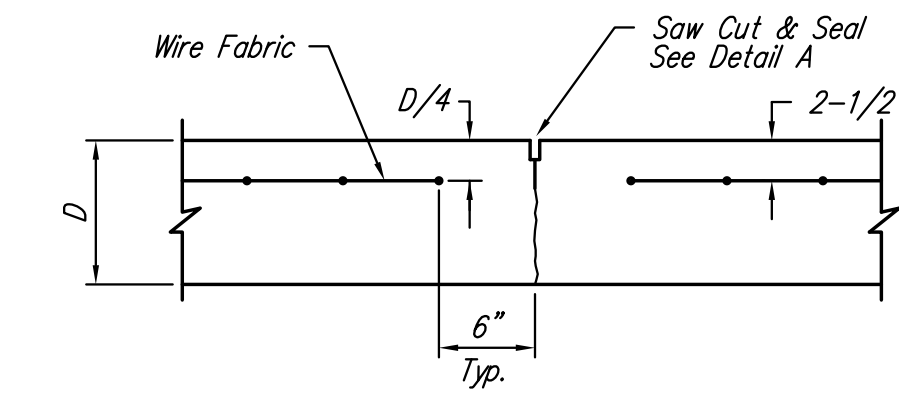

CONTRACTION JOINT DETAIL (C.J.)

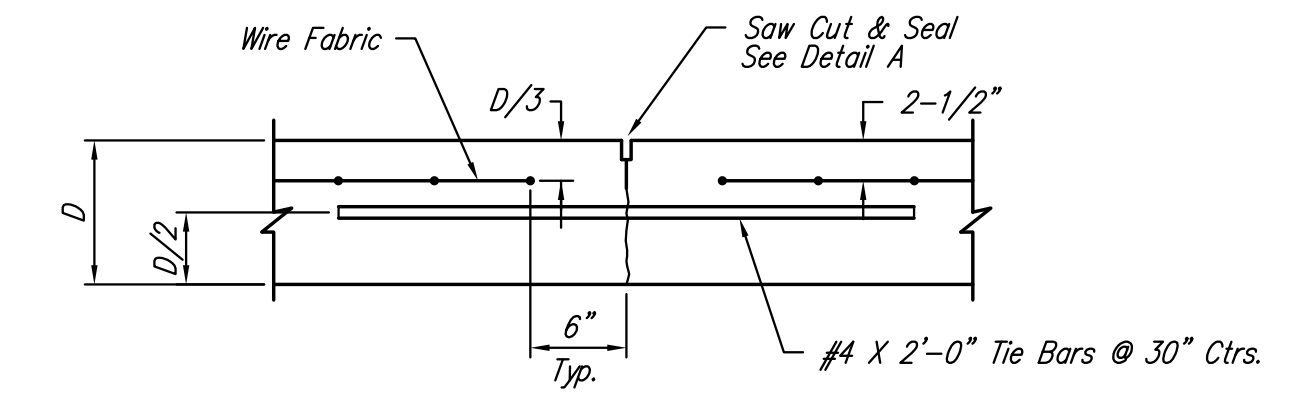

LONGITUDINAL JOINT DETAIL (L.J.)

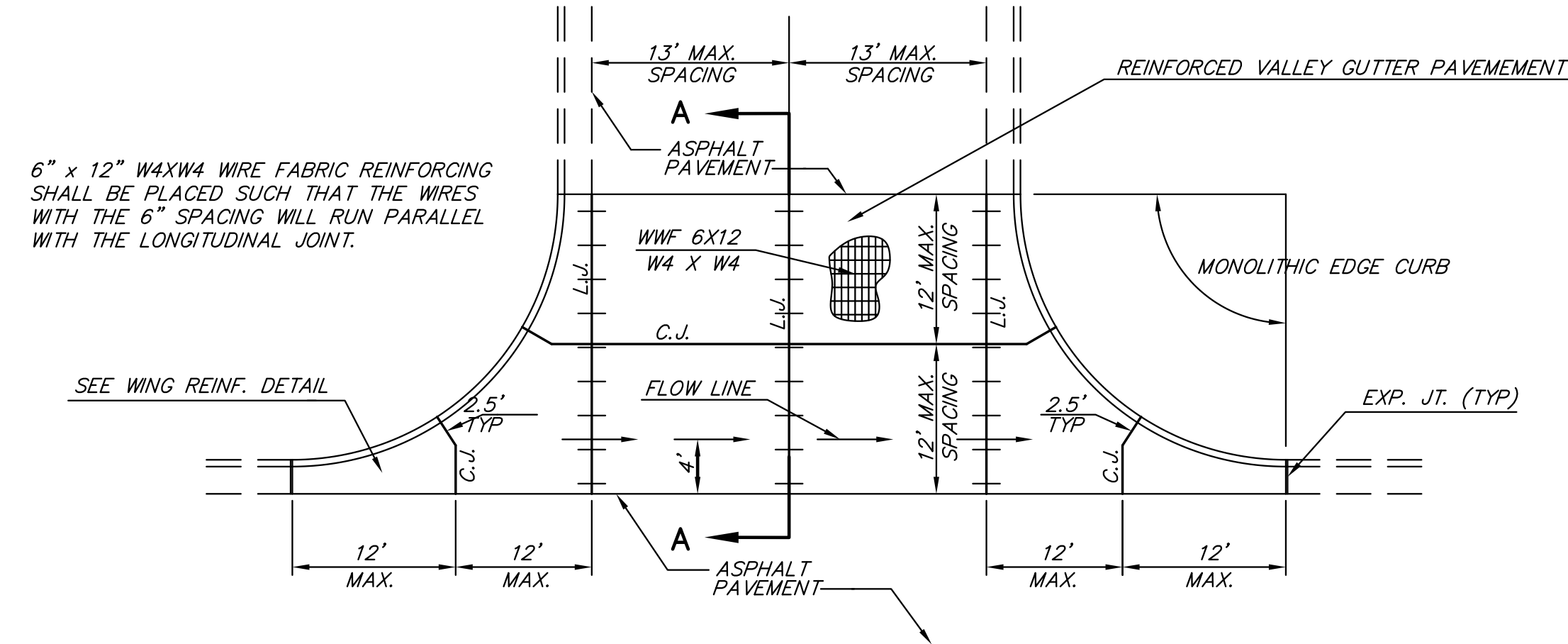

PLAN

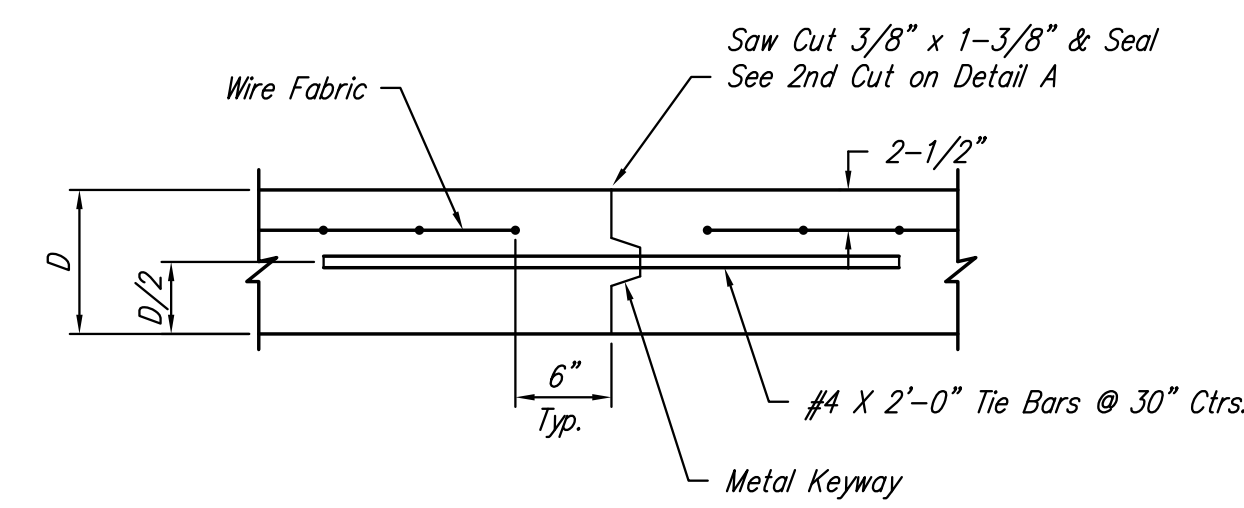

OPTIONAL CONTRACTION JOINT

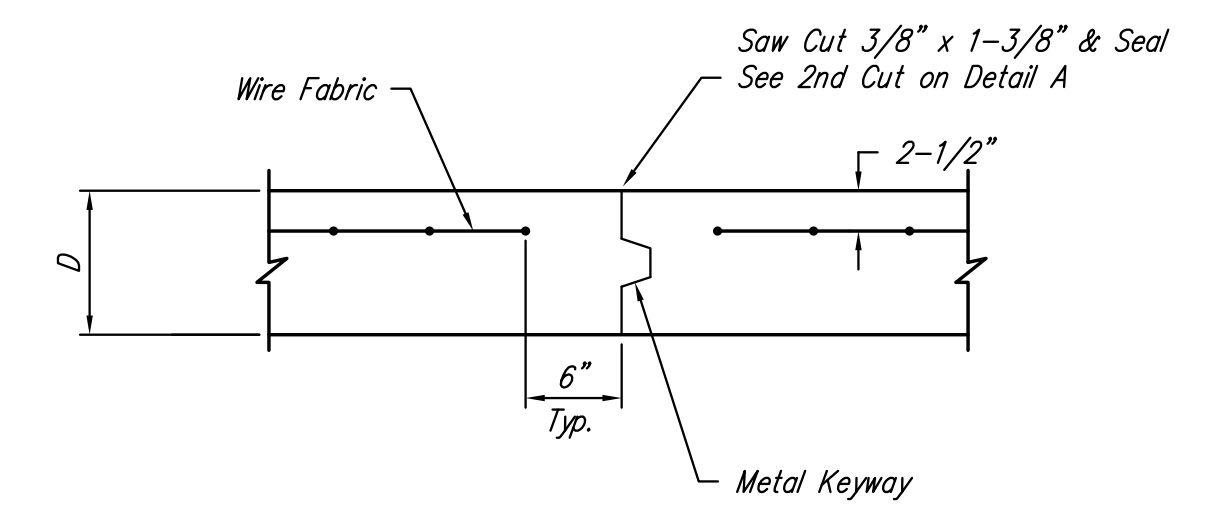

OPTIONAL LONGITUDINAL JOINT DETAIL (L.J.)

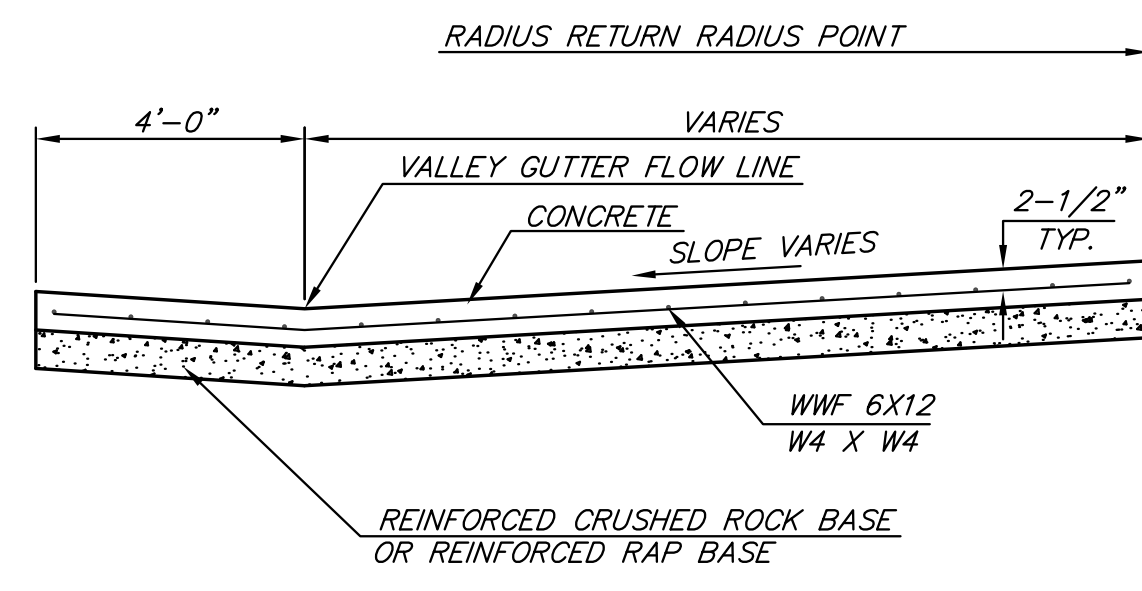

SECTION A-A

REINFORCED VALLEY GUTTER DETAIL

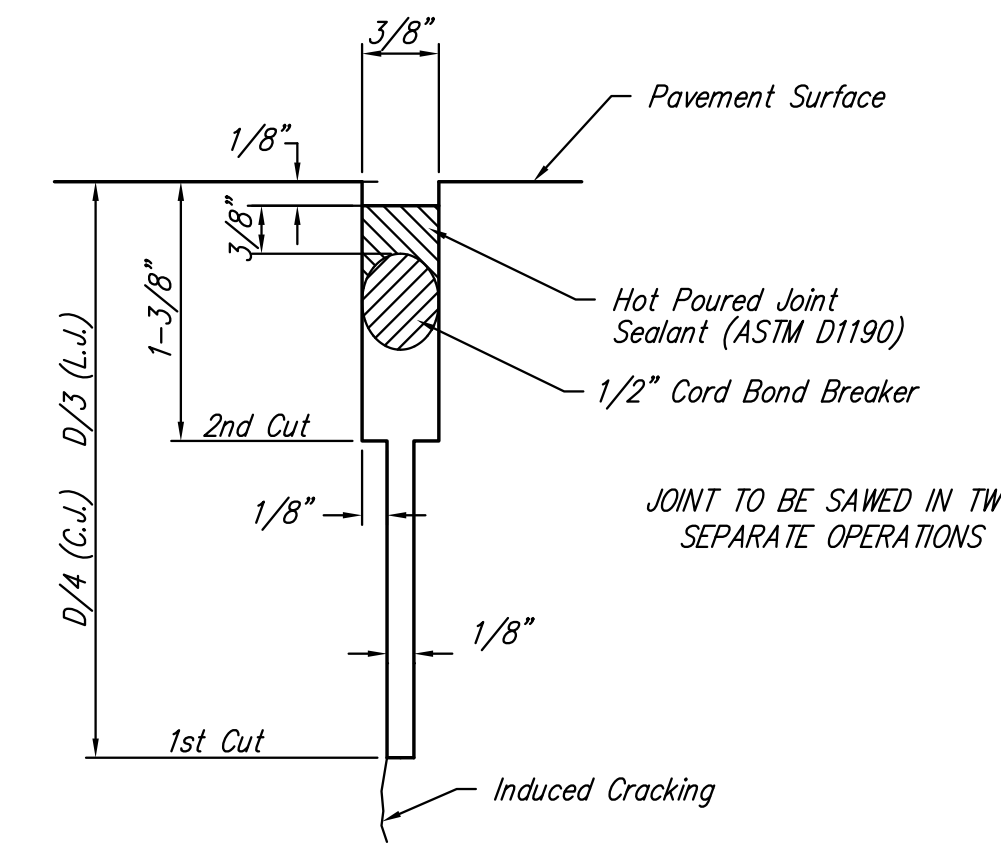

SAW JOINT DETAIL

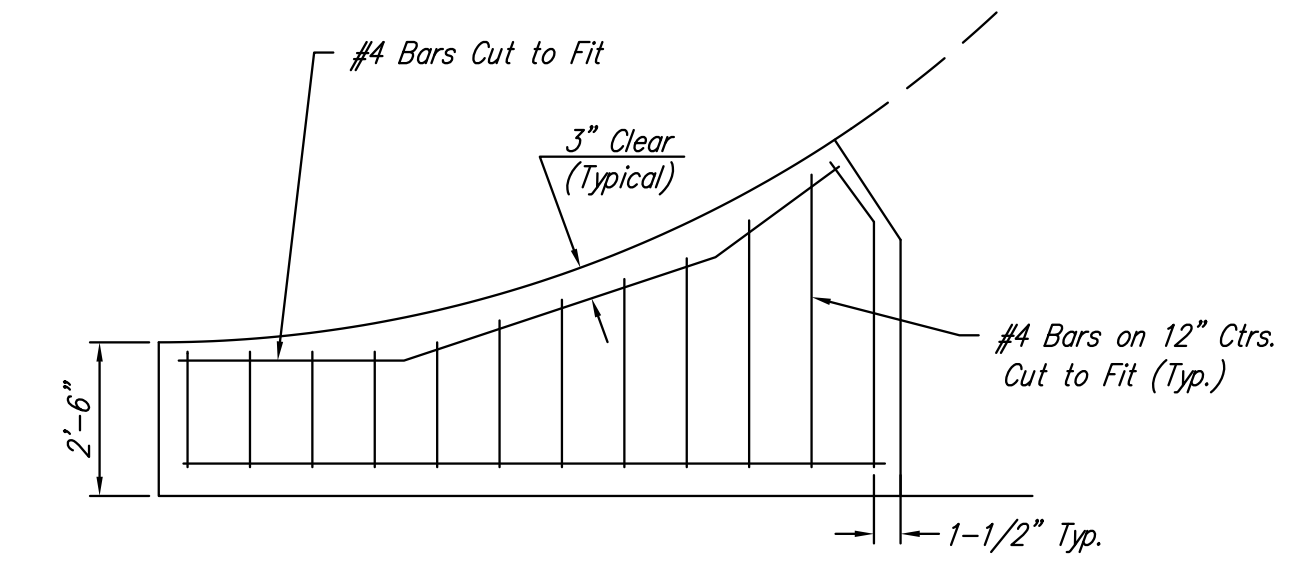

WING REINFORCING DETAIL

| | | |
|--|---------------------------------------|----------------------|
| <p>THE CITY OF WICHITA</p> <p>CITY ENGINEER'S OFFICE CITY HALL - SEVENTH FLOOR 455 NORTH MAIN STREET WICHITA, KANSAS 67202 (316) 268-4501 (316) 268-4114 FAX</p> | VALLEY GUTTER DETAILS | |
| | JAMES L. ARMOUR, P.E. - CITY ENGINEER | |
| | PROJECT NUMBER 472-84758 | OCA NUMBER 785161 |
| | DATE Jul 2010 | Sheet 4 of 23 |

J:\CIVIL\08603\DWG\PAV\08603_ED2.DWG