

SECTION AND ELEVATION
(Along C RCB)

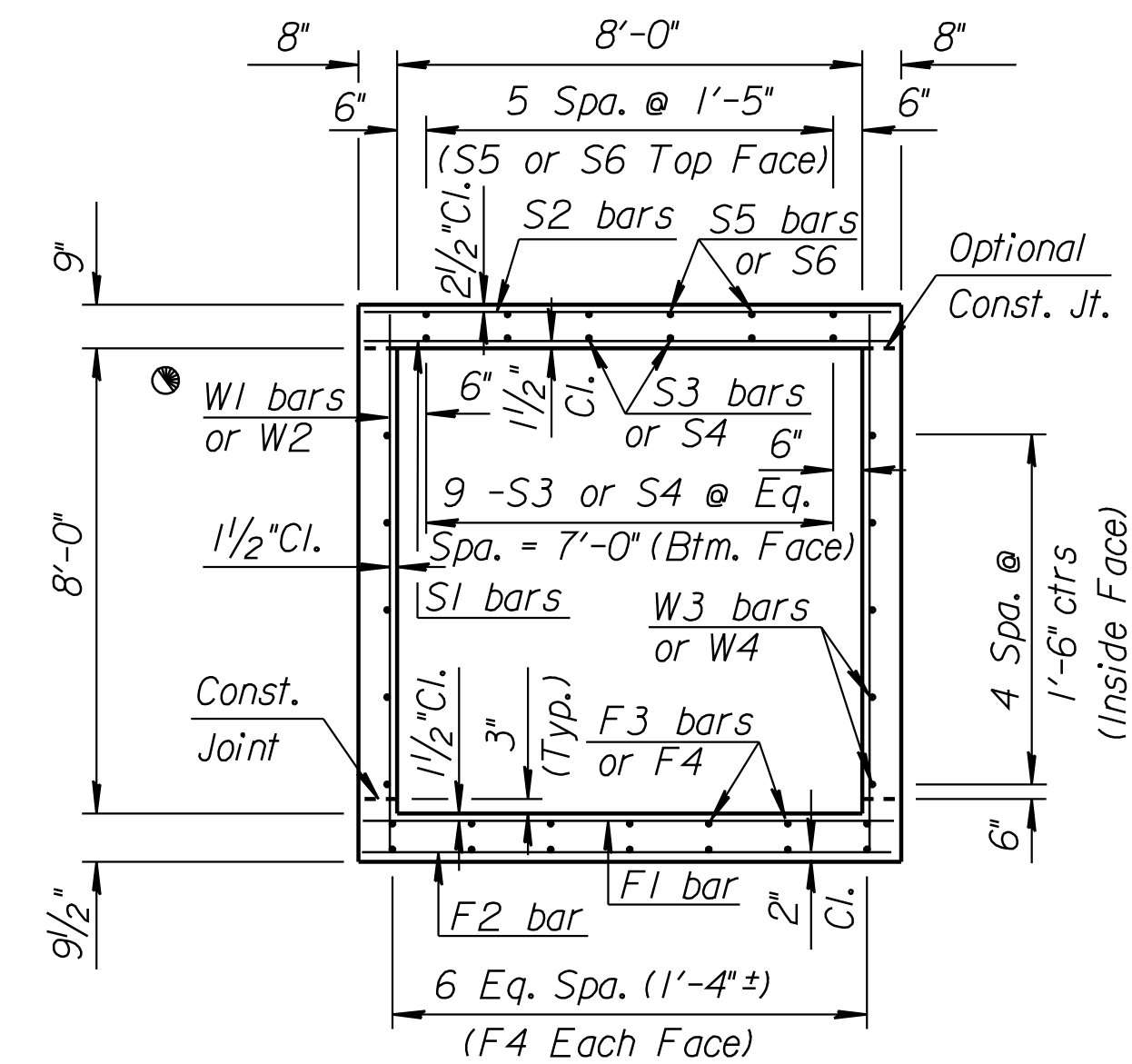

TYPICAL SECTION

See RCB Auxiliary Details for Optional Splice.
See Standard No. RD 080 for additional details.

GENERAL NOTES

- LOADING:** HS20-44 AASHTO Specifications, 1983 Edition.
- UNIT STRESSES:** Grade 4.0 Concrete; $f'c = 4,000$ p.s.i.
Reinforcing Steel; $f_y = 60,000$ p.s.i.
- FILL HEIGHT:** Unless otherwise noted, the Design Fill Height is measured from the riding surface at the culvert and shall include the surfacing.
- CONCRETE:** Grade 4.0 Concrete shall be used throughout. Bevel all exposed edges with a $\frac{3}{4}$ inch triangular moulding. Where Grade 4.0 Concrete (AE) is specified, it shall be placed in the top slab above the Construction Joint.
- REINFORCING:** All reinforcing shall conform to ASTM A615, Grade 60. All dimensions relative to reinforcing steel shall be to centerline of bar unless otherwise noted.
- EXCAVATION:** Excavation for culverts less than bridge length shall not be paid for directly but shall be subsidiary to Grade 4.0 Concrete. Excavation for RCB Bridges shall be paid for as Class III Excavation.
- SEAL COURSE:** A Seal Course may be required by the Engineer. The Seal Course shall be unreinforced Concrete (Commercial Grade) to a minimum depth of 3 inches or as determined by the Engineer. Concrete for the seal course shall be paid for at the unit price set for Concrete for Seal Course.
- FOUNDATION STABILIZATION:** The Foundation Stabilization quantity has been calculated to the limits shown on the "RCB Auxiliary Details" sheet. The depth may be increased by the Engineer. The Contractor may underrun Foundation Stabilization under the barrel if founded on firm material and with the Engineer's approval. Use Foundation Stabilization on all wingwalls unless founded on rock or granular material.
- QUANTITIES:** The quantities shown in the Culvert Summary include apron and/or soil saver quantities when their construction is required by the plans. Payment for additional quantities that result from including seal course and/or floating apron, as a change in original plans, shall be made at the Unit Price bid for the various items involved.
- GRANULAR BACKFILL (WINGWALLS):** Special backfill procedures may be required at the direction of the Engineer. See Auxiliary Details Sheet.
- STRIKE LINE:** Wingwalls and that portion of the RCB outside the Strike Line shall be constructed level. Footing for wingwalls shall be constructed with the culvert floor. See wingwall detail sheet.
- PAYMENT:** The Single 8'x8' RCB Drop Section shall be included in the Lump Sum bid item "Pipe, RCBC (8'x8') (Cast-In-Place Transition)" which shall include all reinforcing steel, concrete, foundation stabilization and any other incidentals required for construction. Quantities are shown for information only.

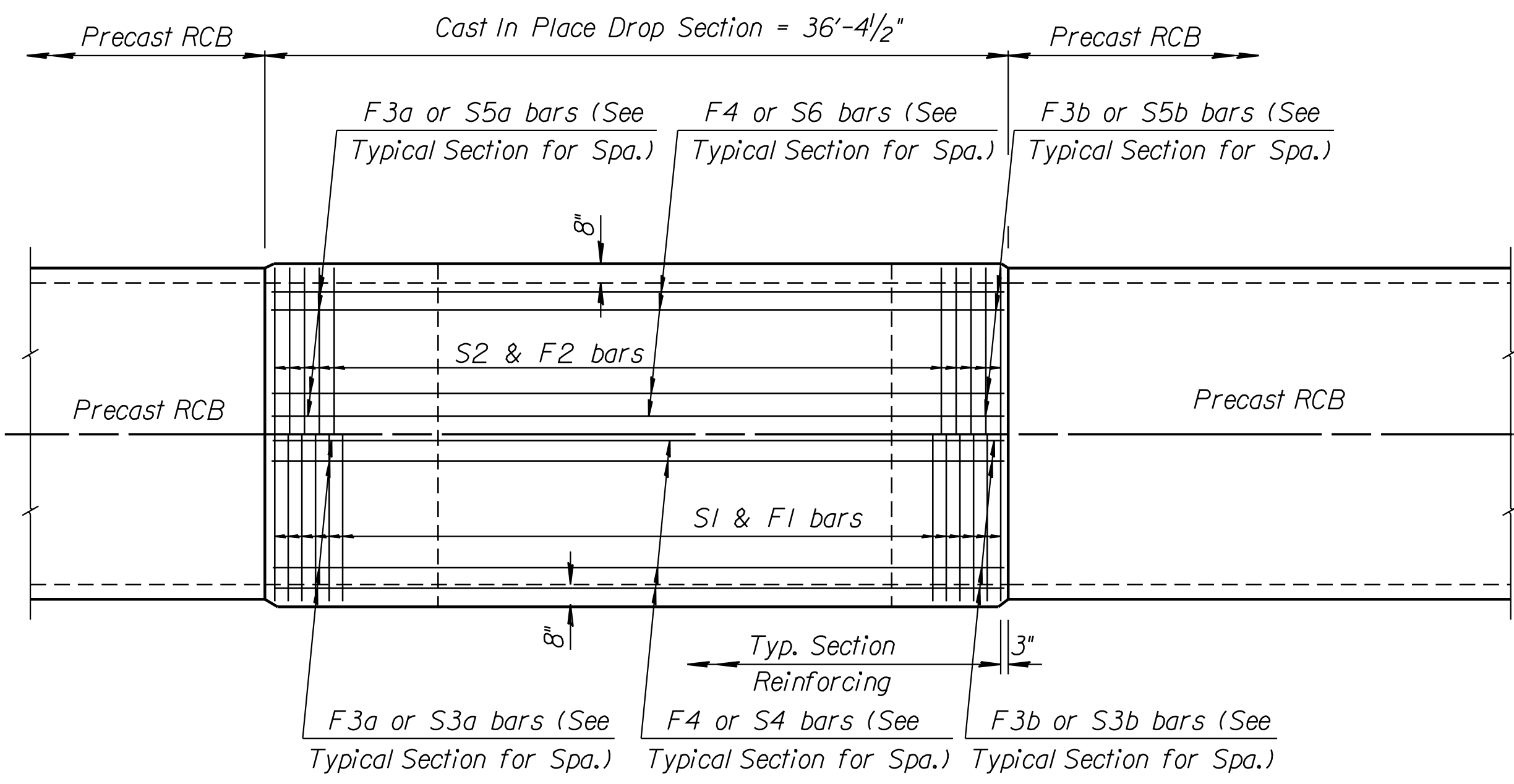

PLAN

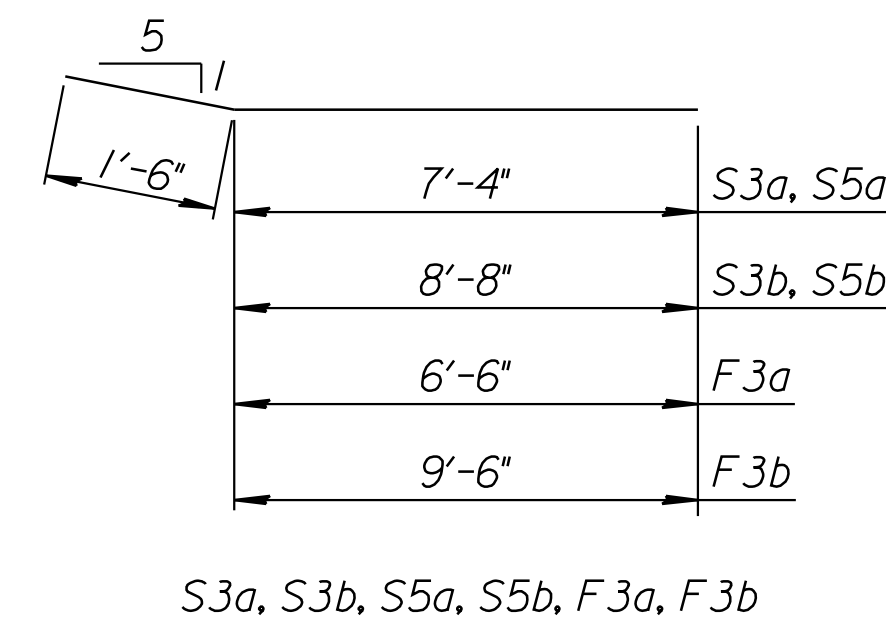

BENDING DIAGRAM

All Dimensions are out to out of bars.

CULVERT SUMMARY													Concrete				Reinf. Steel (Gr. 60)			
Floor Elev. 1	Floor Elev. 2	Floor Elev. 3	Floor Elev. 4	Crown Gr. Elev.	Design Fill Ht.	Skew	Wings	Scour Apron	Soil Saver	Barrel (Cu.Yds.)	Total (Cu.Yds.)	Barrel (Lbs.)	Total (Lbs.)	Barrel (Lbs.)	Total (Lbs.)					
1306.40	1306.37	1302.48	1302.43	1319.00	0	0	FLARED	YES	NO	34.1	34.1	4,958	4,958							

BAR SCHEDULE																								* See Bending Diagram																										
F1						F2						F3a *				F3b *				F4				S1				S2				S3a *				S3b *														
Size	Spa.	No.	Length	Size	Spa.	No.	Length	Size	No.	Length	Size	No.	Length	Size	No.	Length	Size	Spa.	No.	Length	Size	Spa.	No.	Length	Size	Spa.	No.	Length	Size	Spa.	No.	Length	Size	Spa.	No.	Length	Size	Spa.	No.	Length										
6	6"	73	9'-0"	5	7 1/2"	58	9'-0"	4	14	8'-0"	4	14	11'-0"	4	14	20'-5"	6	6"	73	9'-0"	5	7 1/2"	58	9'-0"	5	9	8'-10"	5	9	10'-2"																				
S4						S5a *						S5b *				S6				W1				W2				W3a				W3b				W4														
5	9	20'-5"	4	6	8'-10"	4	6	10'-2"	4	6	20'-5"	4	9	50	9'-2"	4	9	62	9'-2"	4	10	9'-6"	4	10	11'-0"	4	10	26'-4"																						

Minimum Splice Lengths	
#4	1'-4"
#5	1'-8"
#6	2'-0"

** SUMMARY OF QUANTITIES	
Concrete (Grade 4.0(AE))	34.1 C.Y.
Reinforcing Steel (Gr. 60)	4,958 Lbs.

** - For Information Only

ADAPTED FROM KDOT STANDARD BR 1.8.8 P

Plotted By: rjm
File: A20090830708307-000-8X8-RCB_Trans_Details.dgn
Plot Date: 6/30/2010

NO.	DATE	REVISIONS	BY	APP'D
HEARTLAND PREPAREDNESS CENTER SINGLE 8' x 8' REINFORCED CONCRETE BOX				
SINGLE 8 ft x 8 ft RCB DROP SECTION				
JAMES L. ARMOUR, P.E. - CITY ENGINEER CITY OF WICHITA PROJ. NO. 472-84890				
FHWA APPROVAL		6-5-91 APP'D		KENNETH F. HURS
DESIGNED	DETAILED	QUANTITIES	TRACED	
DESIGN CK.	DETAIL CK.	QUAN. CK.	TRACE CK.	