

BY	DATE

Plotted on: 04-JAN-2005 13:13 *Times
 djmlson Plot Queue: #queue*
 Plot Scale: #scale* Pen Table: #pentables
 Design Filename: k:\b29049\brldgesDec2004\Base Bld\Central\drawings\05.dgn.

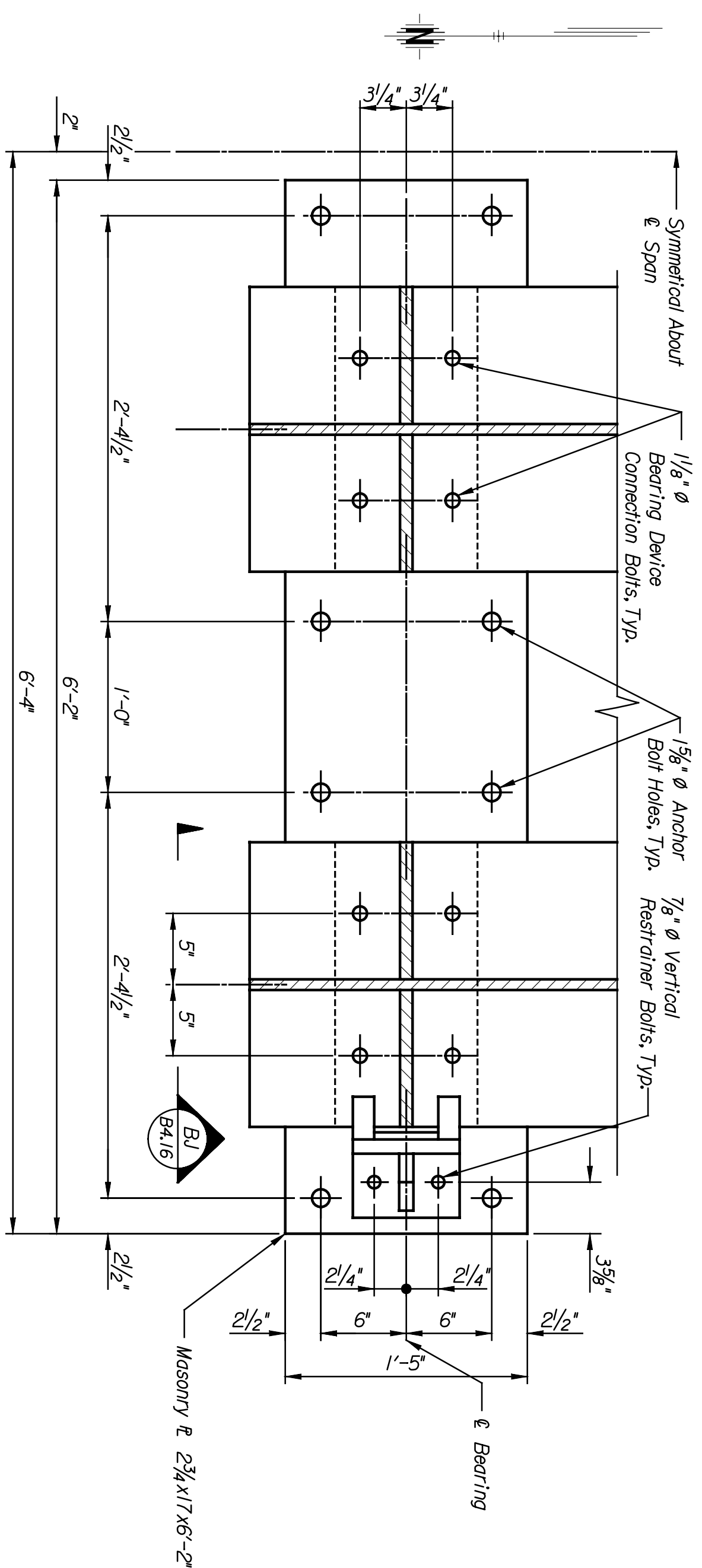

EXPANSION BEARING PLAN
 Scale: 1/2" = 1'-0"

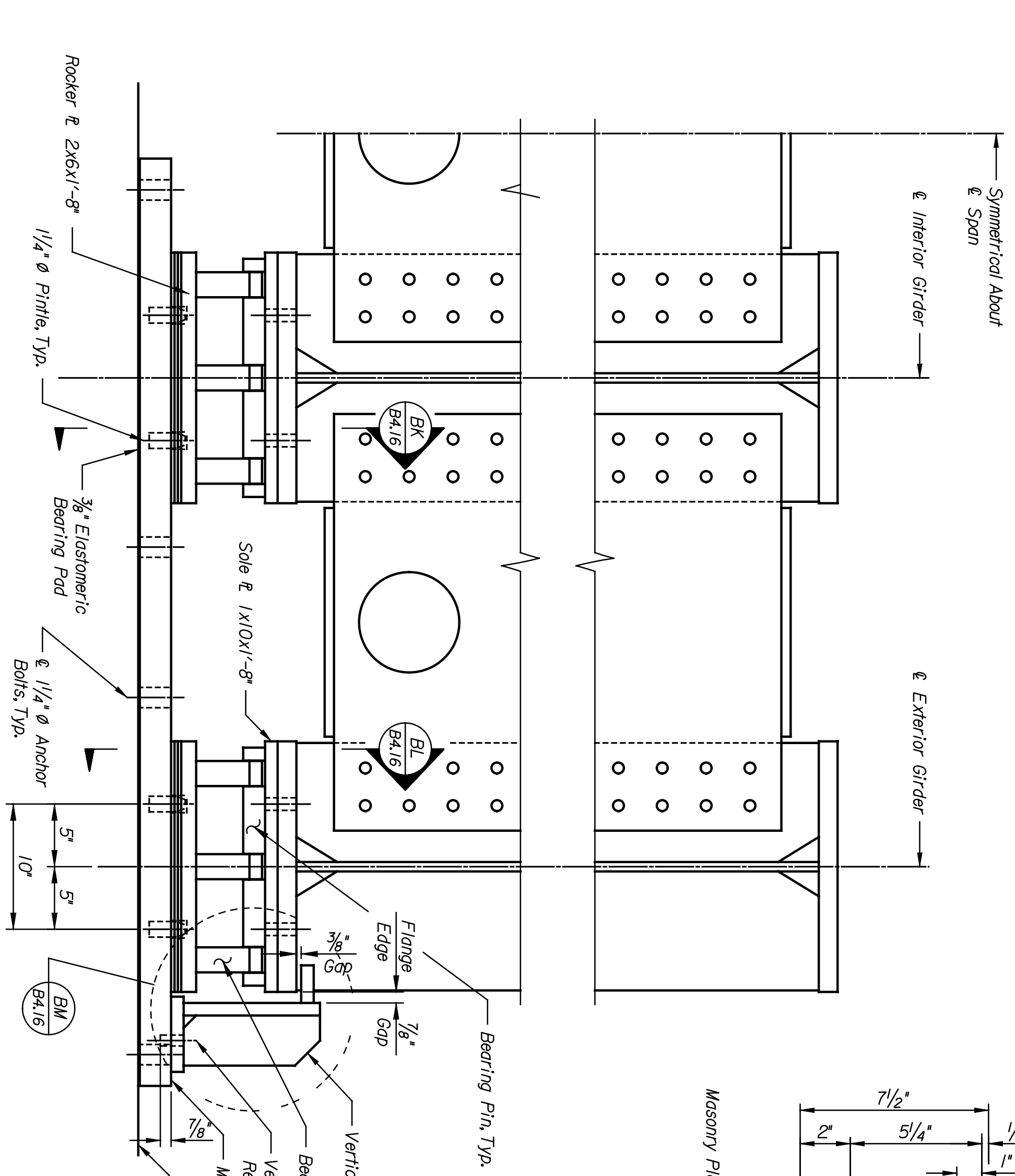

EXPANSION BEARING ELEVATION
 Scale: 1/2" = 1'-0"

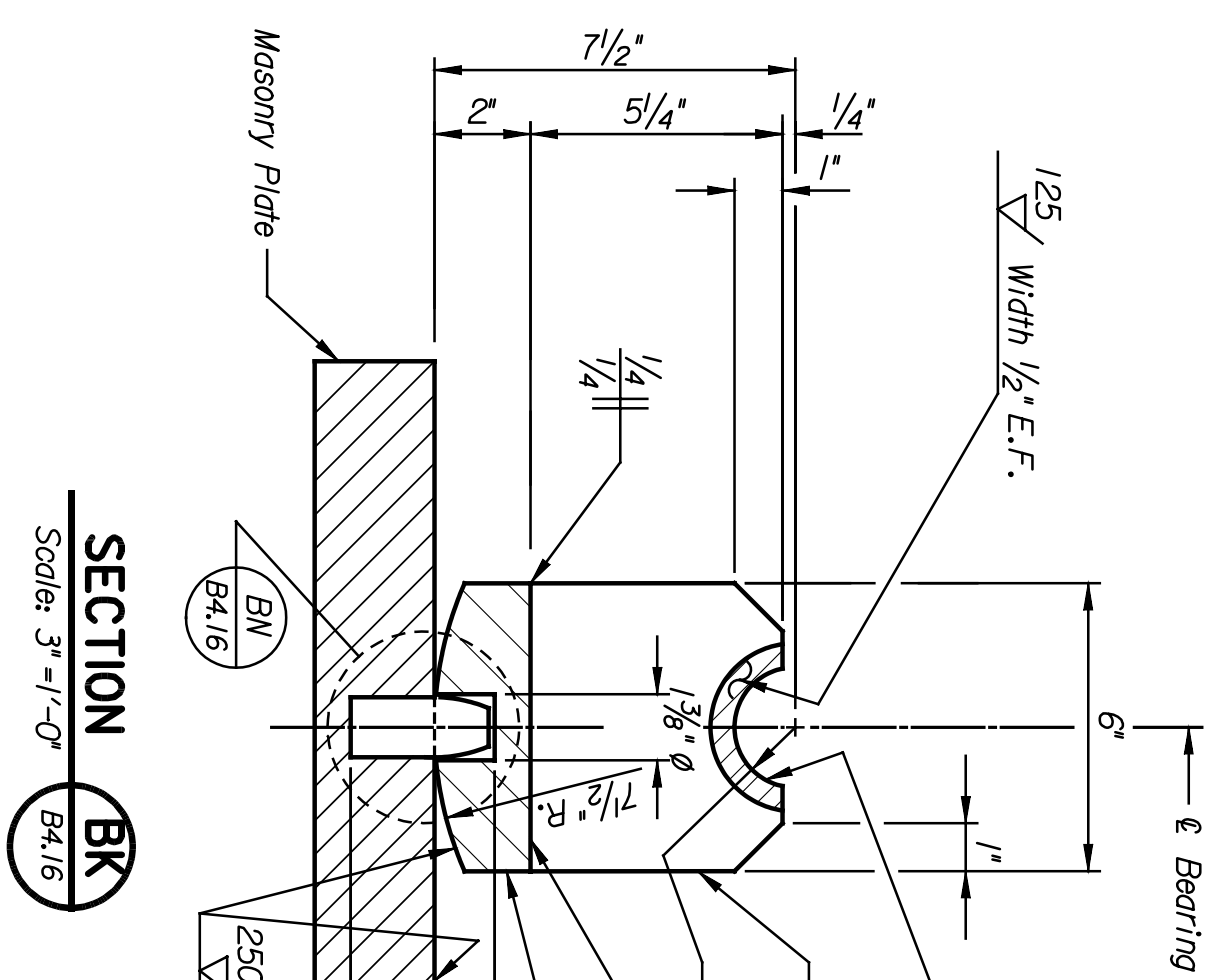

SECTION BK
 Scale: 3" = 1'-0"

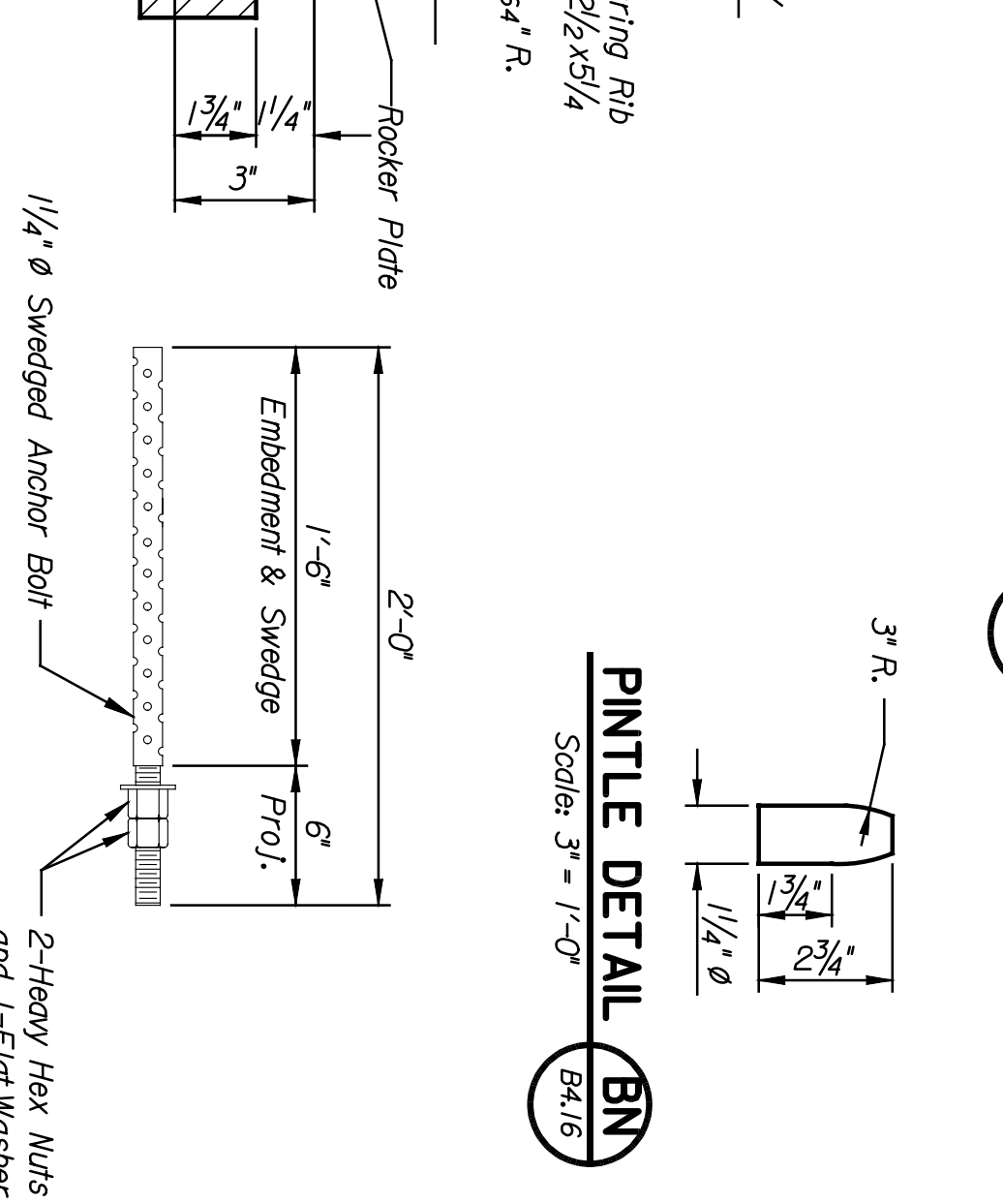

ANCHOR BOLT DETAIL FOR EXPANSION BEARINGS
 Scale: 1/2" = 1'-0"

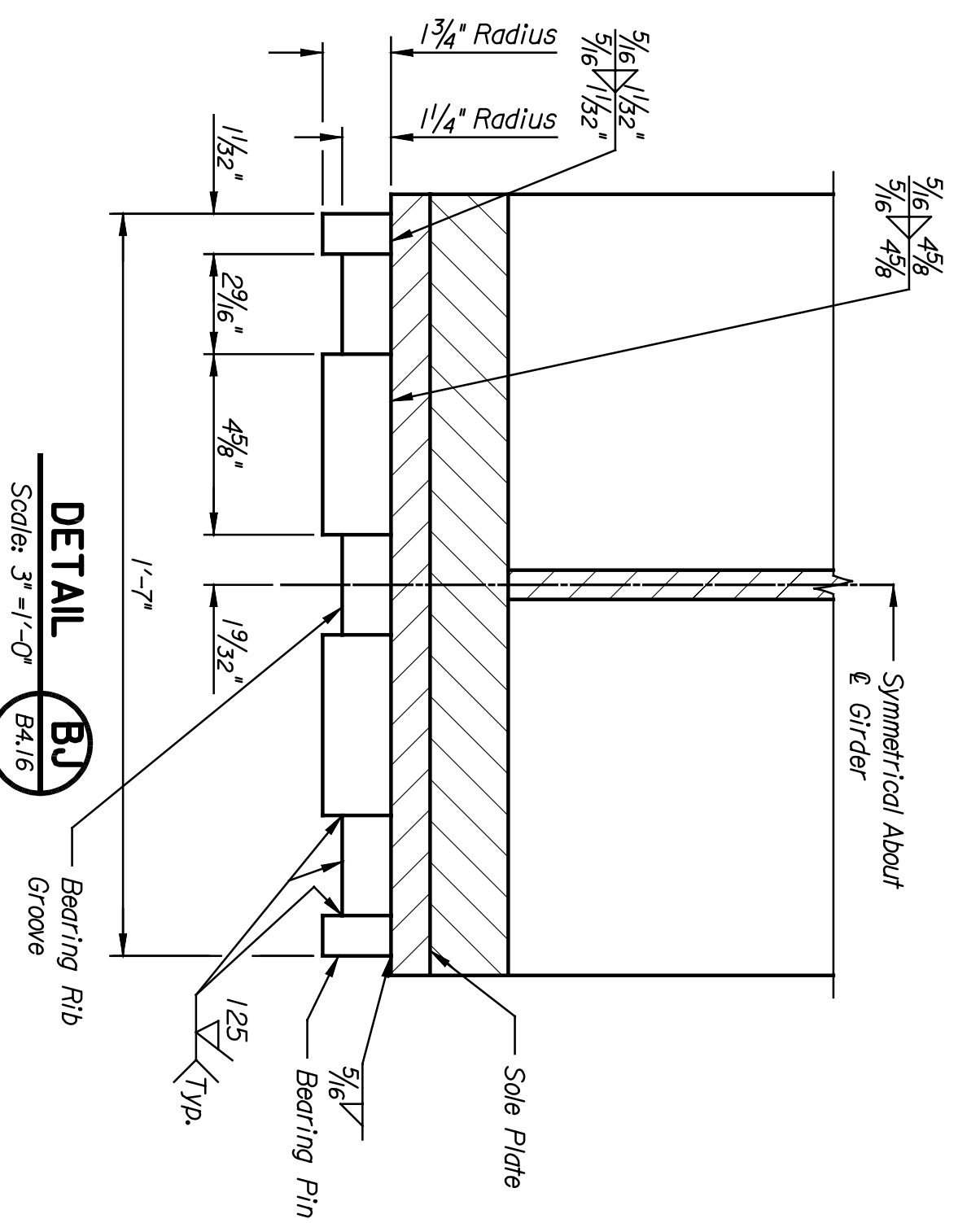

DETAIL BJ
 Scale: 3" = 1'-0"

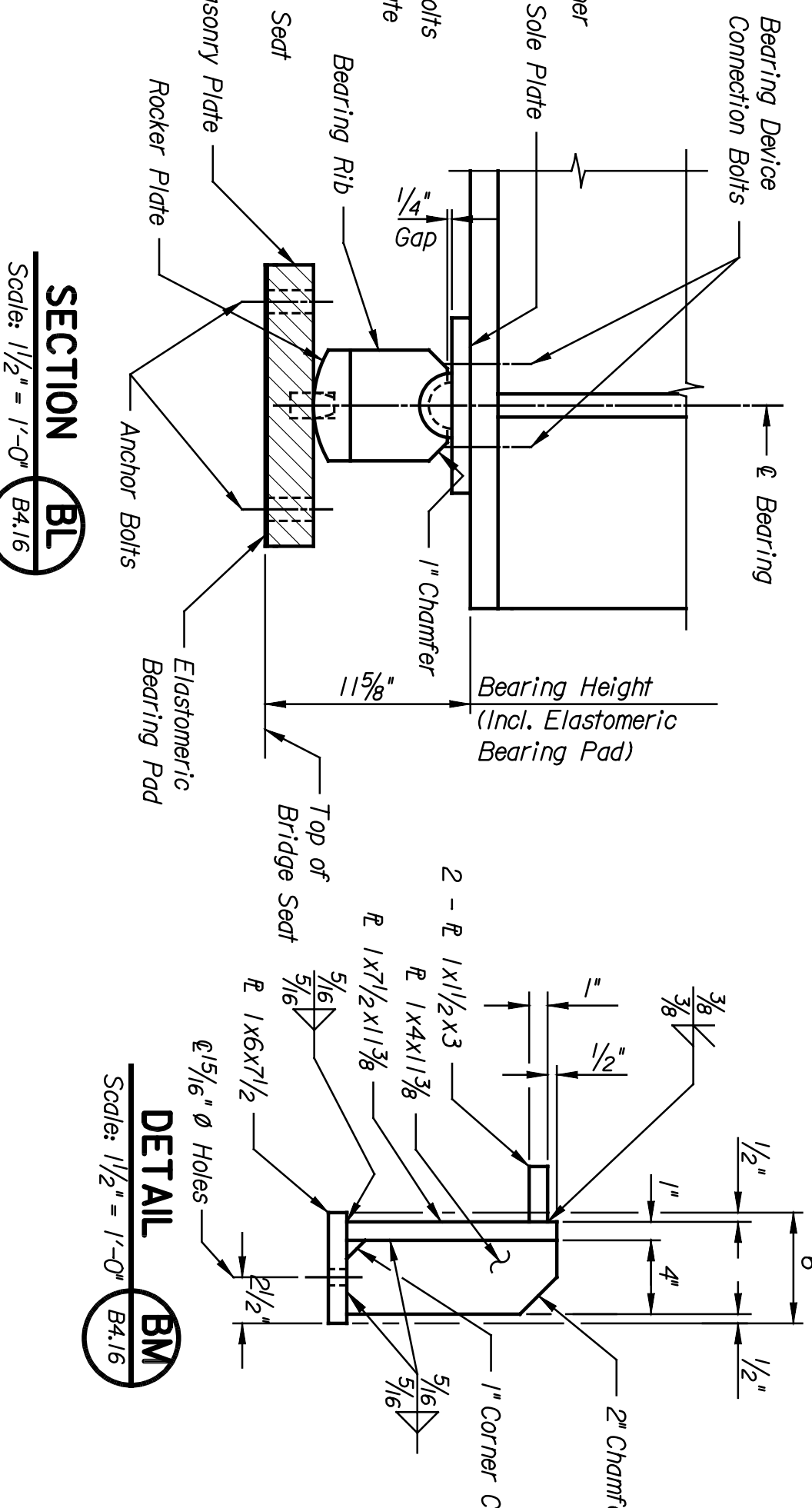

SECTION BL
 Scale: 1/2" = 1'-0"

DETAIL BM
 Scale: 1/2" = 1'-0"

PNTB
 ARCHITECTS ENGINEERS PLANNERS

This sheet designed by:

STATE	PROJECT NO.	YEAR	SHEET NO.	TOTAL SHEETS
KANSAS	472-84071	2005	B416	

NOTES:
 Fabrication and workmanship shall conform to the AREMA Manual for Railway Engineering.
 All structural steel for bearings shall conform to ASTM A709 Grade SOT2, unless noted otherwise.
 The bearing device fasteners shall be of the size shown and shall be Heavy Hex Structural Bolts, ASTM A325 Type 1; each with one circular Hardened Washer, ASTM F436 Type 1.
 Vertical restrainer fasteners shall be of the size shown and shall be Heavy Hex Structural Bolts, ASTM A325 Type 1; each with one circular Hardened Washer, ASTM F436 Type 1.
 All fastener holes, except anchor bolts or tapped holes, will be 1/16" larger than the nominal fastener diameter, unless noted otherwise.
 Drill & tap (full depth) the bearing device sole plates for bearing device fasteners.
 Drill & tap (as shown) the bearing device masonry plates for vertical restrainer fasteners.
 Anchor bolts for expansion bearings shall be of the size shown and composed of steel conforming to ASTM F1554 Grade 105, Class 1A or 2A, with Supplementary Requirement S3; each with one circular Hardened Washer, ASTM F436 Type 1; and two Heavy Hex Nuts ASTM A563 Grade DH, A563 Grade A.
 Anchor bolts for fixed bearings shall be of the size shown and composed of steel conforming to ASTM F1554 Grade 105, Class 1A or 2A, with Supplementary Requirement S3; each with one circular Hardened Washer, ASTM F436 Type 1; and two Heavy Hex Nuts ASTM A563 Grade DH, A563 Grade A.
 Anchor bolt holes will be 3/8" larger than the nominal diameter of the anchor bolt, unless noted otherwise.
 All washers shall be located under the turned element.
 Welding shall conform to the AREMA Manual for Railway Engineering and the Bridge Welding Code, AWS D1.5M/D1.5.
 All weld metal shall be equivalent to the base metal in strength, corrosion resistance and painted appearance.
 The steel surface preparation for coatings shall be in accordance with SSPC-10, "Near-White Blast Clean" and the specifications.
 All bearing device surfaces shall be thermally sprayed with an 85%Zinc/15%Aluminum alloy with a minimum thickness of 6.0 mils in accordance with the plans and specifications.
 Thermal spraying will be in accordance with AWS C2.18-93, "Guide for the Protection of Steel with Thermal Sprayed Coatings of Aluminum and Zinc and their Alloys and Composites" and the specifications.
 One top coat of water-borne acrylic or hi-build polyurethane paint, with a minimum dry film thickness of 3.0 mils and a maximum dry film thickness of 4.0 mils, shall be applied in accordance with the specifications over the thermally sprayed bearings.
 The top coat of paint (semi-gloss white) shall be color-matched to the color of the finished abutment concrete.
 Prior to painting, submit samples to the Engineer for approval of the color.
 The steel surface preparation and thermal spraying shall be applied at the fabrication shop.
 The top coat of paint shall be applied in the field after erection and assembly.
 Machined surfaces shall be coated in accordance with the specifications.
 The steel for the expansion bearing primels shall conform to ASTM A668 Class G.
 Provide a FN 2 fit between the primel and masonry plate in accordance with ANSI B4.1, "Preferred Limits and Fits for Cylindrical Parts".
 Surface finish symbols are in accordance with ANSIR14.36, "Surface Texture Symbols". Roughness averages are shown in micronches (0.000001 inches).
 Measure surface finishes in accordance with ANSIR14.36, "Surface Texture (Surface Roughness, Waviness and Lay)".
 Each bearing shall be shop assembled to assure a proper fit.
 Elastomeric bearing pads, to provide a level bearing surface, shall be provided in accordance with the specifications and are subsidiary to the steel bearings.
 Anchor bolts, washers and heavy hex nuts are subsidiary to the steel bearings.

LOCATION:	SCALE AS NOTED	APPD.
RMSF BR 2018	DESIGNED: EKO	TRACED: DJL
WICHITA, KS	DETAIL: BWH	CHECKED: DJL
	DATE: 01/04/05	DATE: 01/04/05
	BY: DJL	BY: DJL
	APPD: DJL	APPD: DJL

CITY OF WICHITA
WICHITA CENTRAL CORRIDOR
CENTRAL
EXPANSION BEARING DEVICE DETAILS