

	BY	DATE

**TRAFFIC CONTROL NOTES:**

1. If roadway will be under reduced lane configuration for longer than one week concrete barricades should be used to protect the work zone.
- 2) All distances are from the Manual for Uniform Traffic Control Devices (MUTCD). The contractor has the ability to propose alternate methods, however they must conform to this manual.
- 3) These distances are for general layouts and should be considered minimums. Actual placement of signs should be determined in the field to avoid being blocked by other signs or traffic control devices.

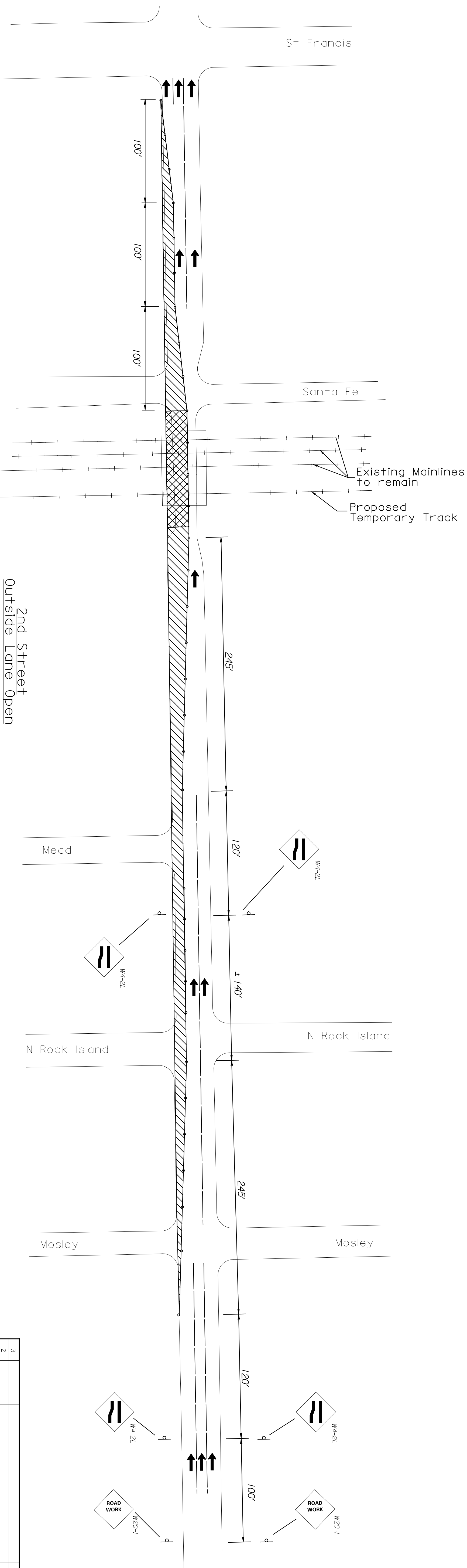
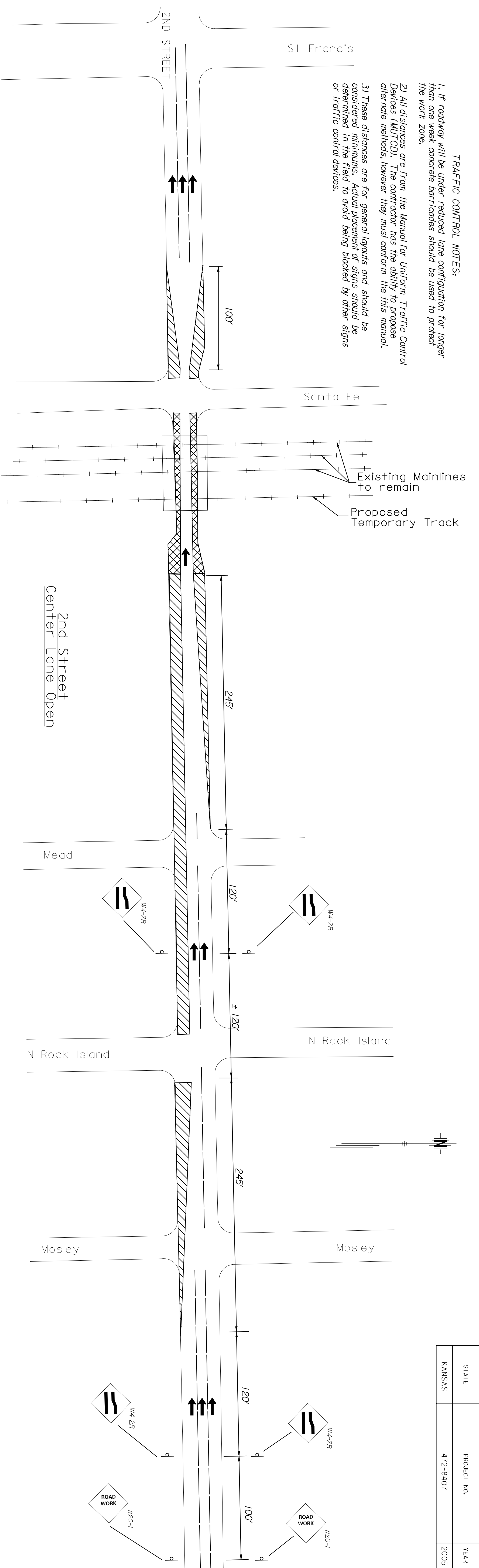

2nd Street  
 Outside Lane Open  
 Temporary and not at  
 the same time as  
 Central

**LEGEND**

- Work Zone
- Protected Area
- Channelizers

This sheet designed by:  
**PNTB**  
 ARCHITECTS ENGINEERS PLANNERS

STATE	PROJECT NO.	YEAR	SHEET NO.	TOTAL SHEETS
KANSAS	472-84071	2005	54,4	

SHEET NO.		OF	SCALE	APP'D.	QUANTITIES	TRACED
DESIGNED			DETAILED			
DESIGN OK.			DETAIL OK.			
<b>CITY OF WICHITA</b> <b>WICHITA CENTRAL CORRIDOR</b> <b>TRAFFIC CONTROL</b> <b>2ND STREET</b>						
NO.		DATE		REVISIONS		BY
3						
2						
1						