

STATE	PROJECT NO.	YEAR	SHEET NO.	TOTAL SHEETS
KANSAS	54-87 K-8258-01	2007	78	556

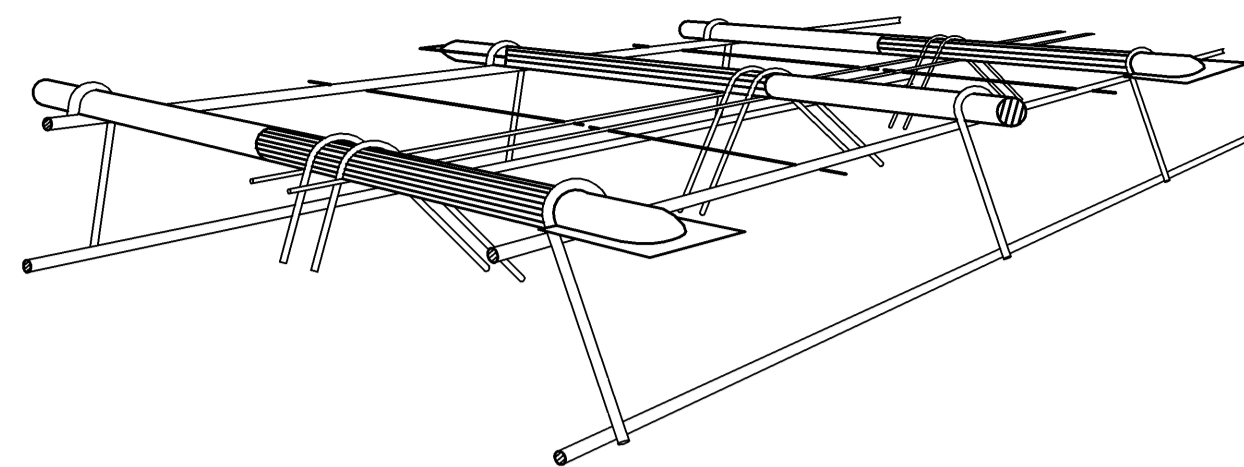

PERSPECTIVE VIEW

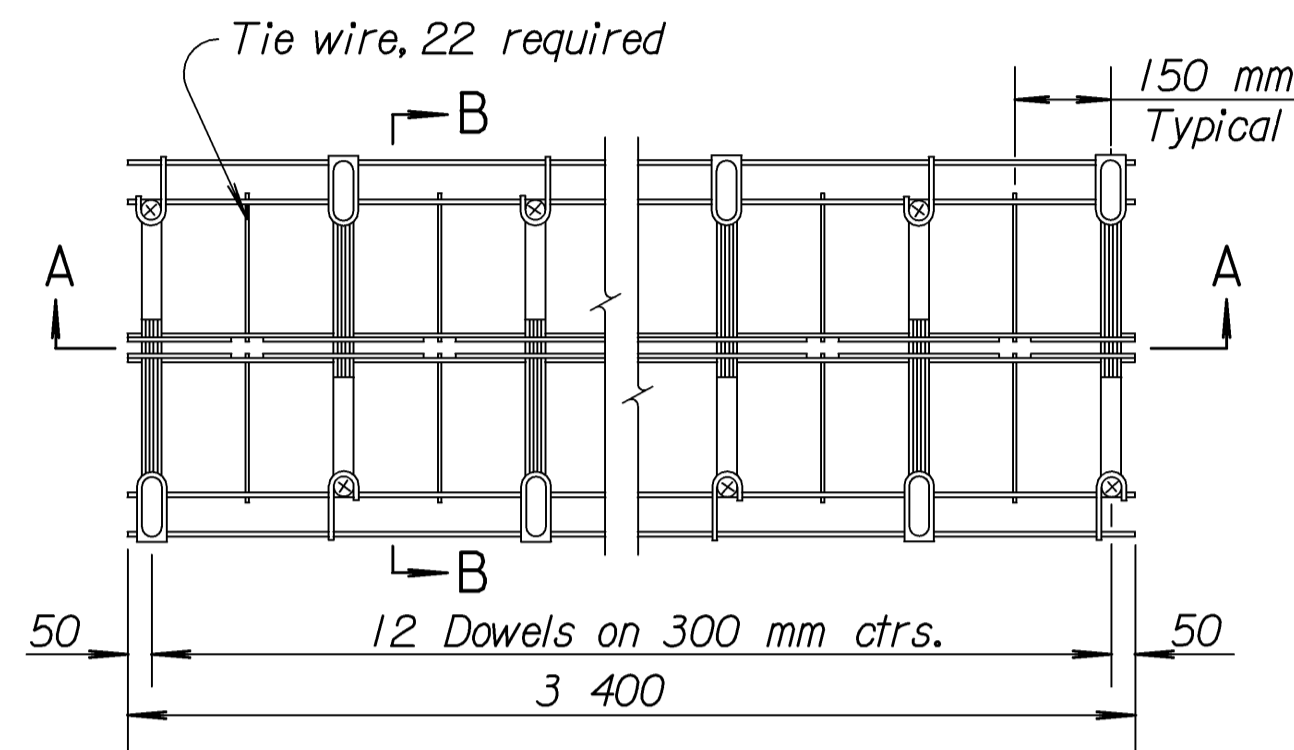

PLAN VIEW

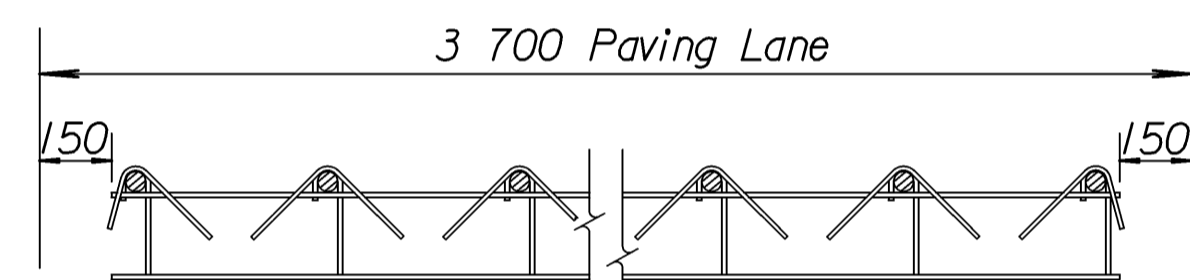

SEC. A-A

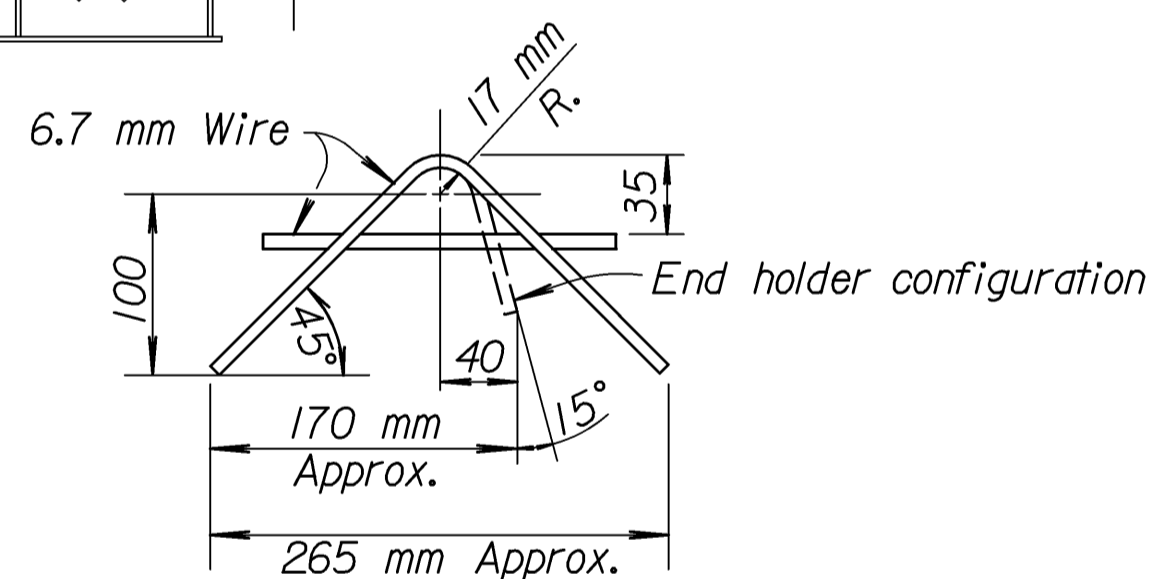

\* See pavement details for size of dowels.

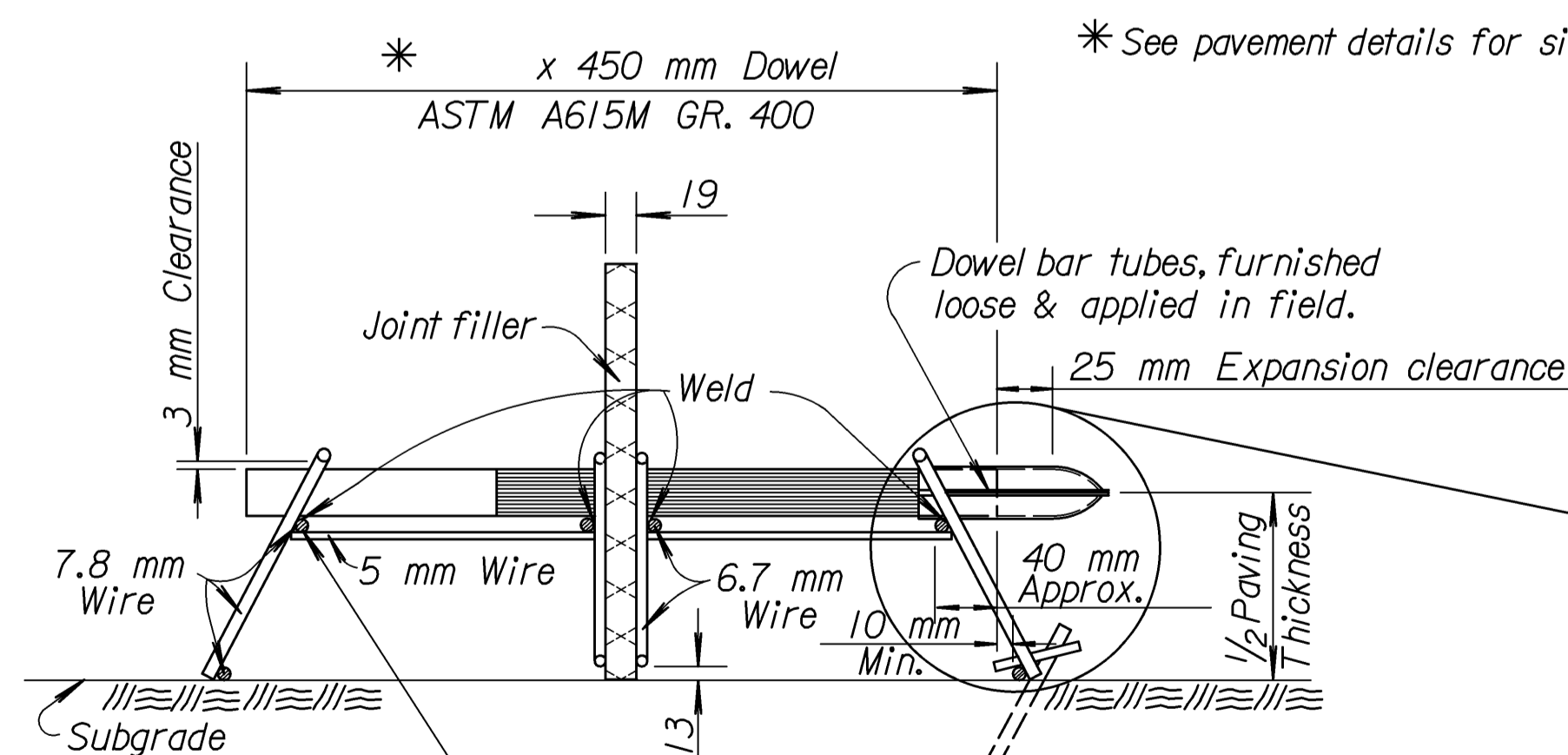

SEC. B-B

EXPANSION JOINT

Note: Wire sizes shown are minimum required.

Sides shall be held together with tie wire, allowing quick separation of sides & insertion of expansion material, provided in field.

One length of Preformed Expansion Joint filler (Type B), or other approved material, cut to fit crown and subgrade shall be used for each lane of pavement as expansion joint filler.

A string line shall be stretched between the pavement forms along the center line of the joint.

Each dowel bar shall be coated with an epoxy coating that meets the standard specifications. The coating material shall be a powdered epoxy resin approved by the Chief, Bureau of Materials and Research and shall be uniformly applied according to accepted practices and the resin manufacturer's recommendations. For Alt. 1 the coating need not be applied to the end faces of the bars and will not be required within 50 mm of the end which will be fixed in the supporting basket by welding.

In order to identify the location of the bond breaker application, the working end of dowel and the supporting leg shall receive a light application of red paint at the place of fabrication. The bond breaker shall be applied in the field prior to concrete placement shall consist of coating approximately three-fifths of the length of each dowel bar with hard grease at the working end identified by the red paint.

The cutting to length of the dowel bars shall be done in such a manner to result in no appreciable deformation of the ends.

The entire joint assembly shall be carefully leveled up so that the dowels are parallel to the slab surface and free to slide in the dowel holders. Any grease scraped off the dowels in assembling the joint shall be replaced. Any excess grease on the dowel holders shall be removed.

After the complete expansion joint is assembled, it shall be checked to be certain that the vertical plane of the joint will be perpendicular to the finished surface of the slab and at a right angle with the center line of the slab. The dowels shall be checked to be certain that they are level and will remain in a position parallel with the finished surface of the slab.

Concrete shall be placed over and adjacent to the joint in accordance with the requirements of the Specifications.

To finish the joint after completion of machine finishing, floating and straight edging of the surface, the concrete over the filler shall be carefully removed and the joint edged with an edge of the proper size. Expansion joint material is to be installed in the field.

Other approved designs may be used in lieu of the type shown.

ALTERNATE WITH SAND PLATE

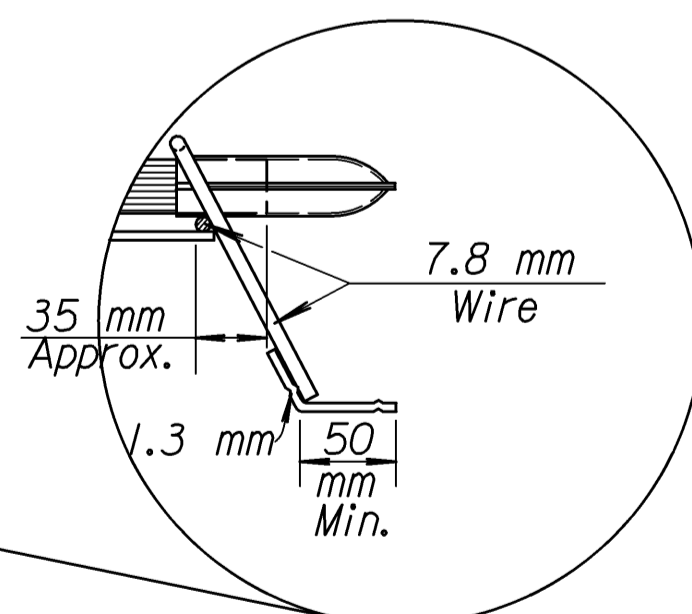

Note: See Contraction Joint for Stake detail.

Stake position at slight angle

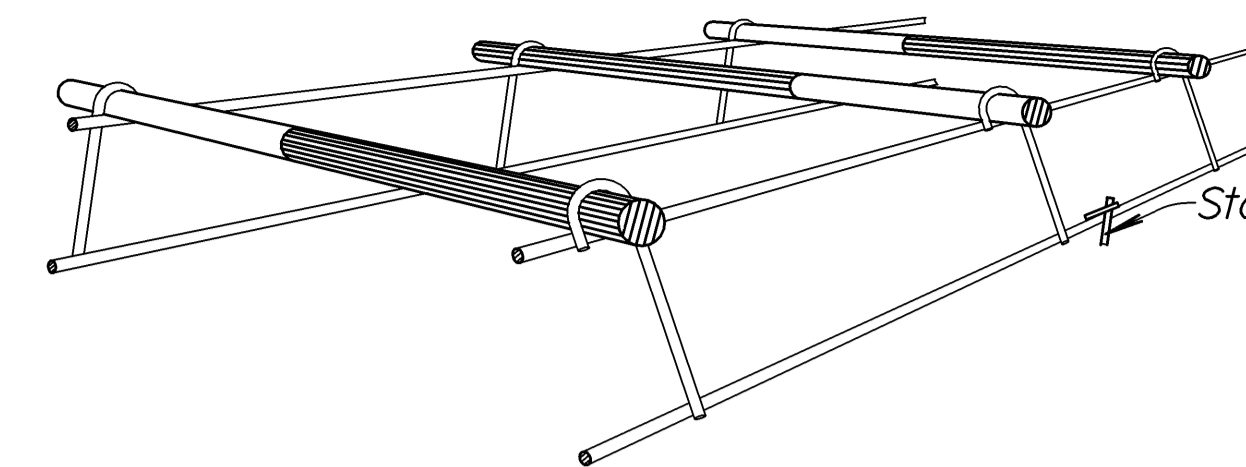

PERSPECTIVE VIEW

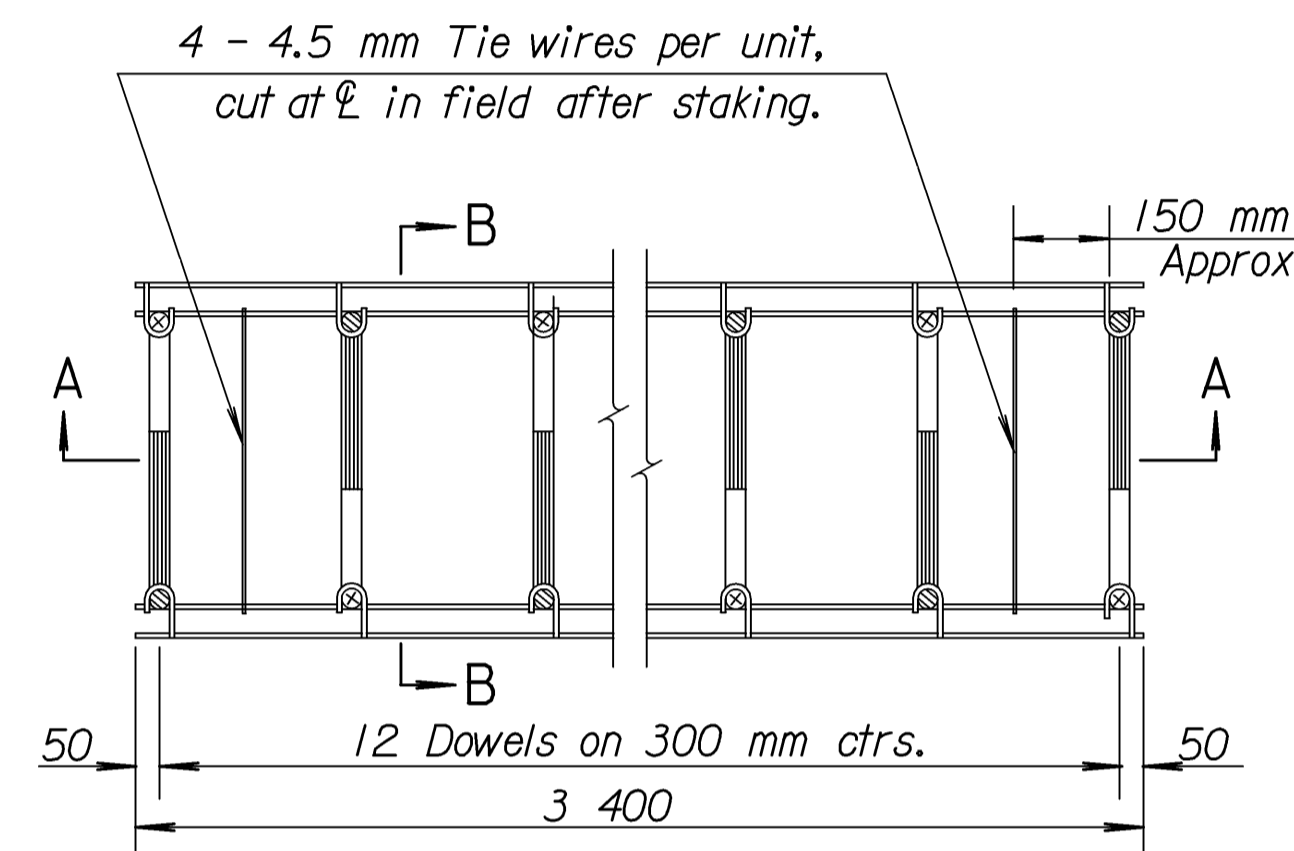

PLAN VIEW

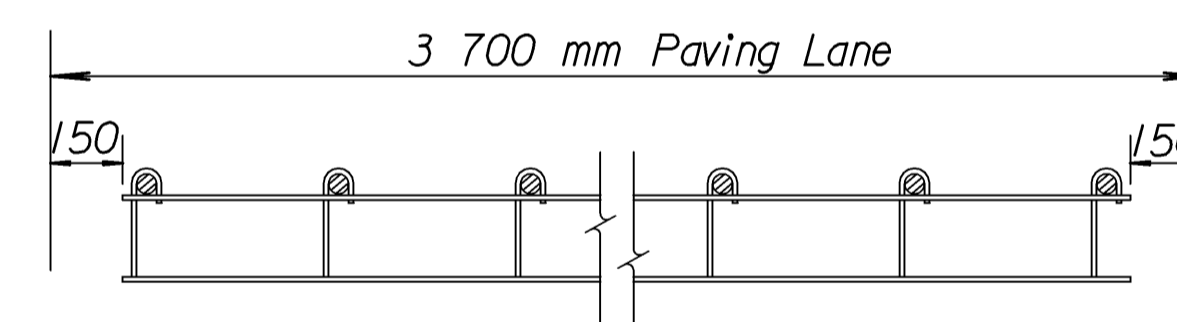

SEC. A-A

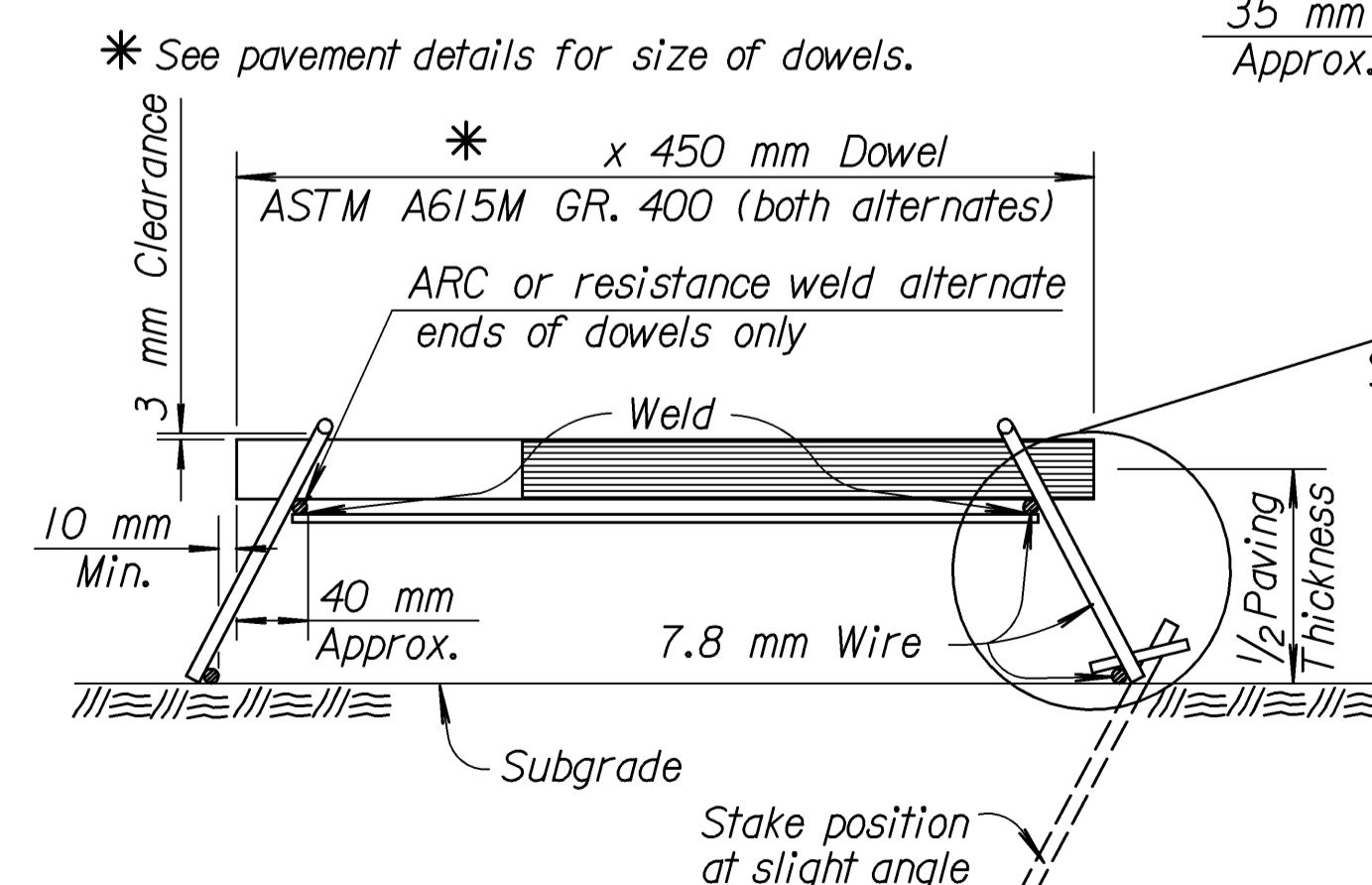

SEC. B-B

CONTRACTION JOINT

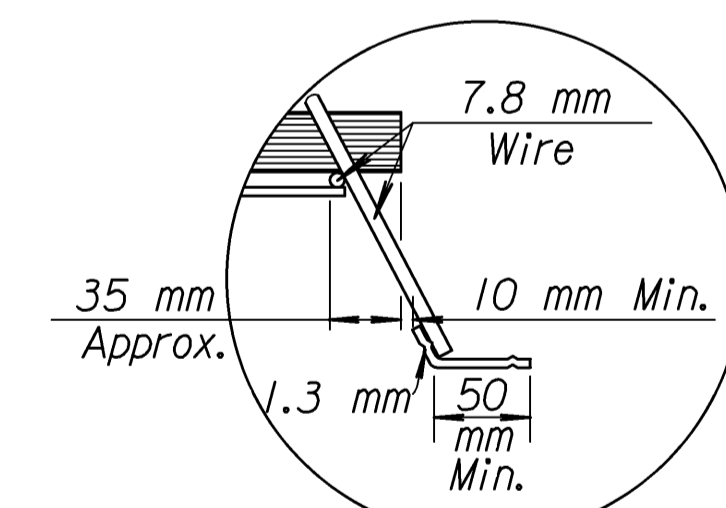

SAND PLATE (Alt. 1)

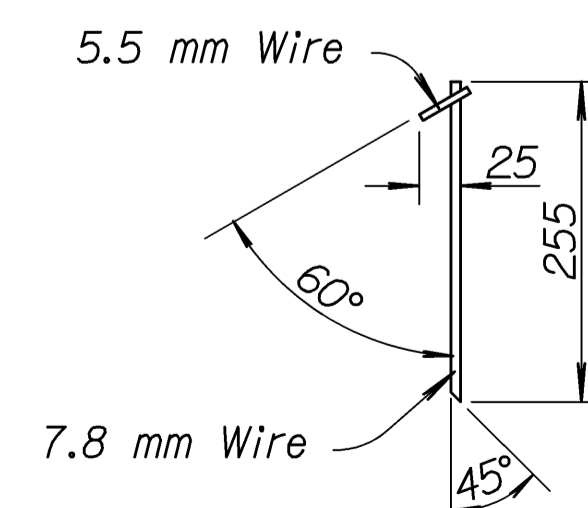

STAKE DETAIL

(6 Pieces minimum required)

GENERAL NOTE

Dowel bar insertion may be by mechanical dowel placers regardless of the joint spacing.

Each dowel bar shall be coated with an epoxy coating that meets the standard specifications. The coating material shall be a powdered epoxy resin approved by the Chief, Bureau of Materials and Research and shall be uniformly applied according to accepted practices and the resin manufacturer's recommendations. For Alt. 1 the coating need not be applied to the end faces of the bars and will not be required within 50 mm of the end which will be fixed in the supporting basket by welding.

The cutting to length of the dowel bars shall be done in such a manner to result in no appreciable deformation of the ends.

Alt. 1 (Baskets)

Wire sizes shown are minimum required.

Basket shall be staked to sub-grade, as shown. Ramset or similar type fastener with clip to be used when subgrade condition requires it.

A string line shall be stretched between the pavement forms along the center line of the joint. The position of the joint shall be carefully marked so that the saw cut will coincide with the center line of the joint.

In order to identify the location of the bond breaker application, the working end of dowel and the supporting leg shall receive a light application of red paint at the place of fabrication. The bond breaker shall be applied in the field prior to concrete placement shall consist of coating approximately three-fifths of the length of each dowel bar with hard grease at the working end identified by the red paint.

The entire joint assembly shall be carefully leveled so that the dowels are parallel to the slab surface and free to slide in the dowel holders. Any coating scraped off the dowels in assembling the joint shall be replaced.

After the complete contraction joint is assembled, it shall be checked to be certain that the vertical plane of the joint will be perpendicular to the finished surface of the slab and at a right angle with the center line of the slab unless shown otherwise on the plans. The dowels shall be checked to be certain that they are level and will remain in a position parallel with the finished surface of the slab.

Concrete shall be placed over and adjacent to the joint in accordance with the requirements of the Specifications.

Other approved designs may be used in lieu of the type shown.

Alt. 2 (Mechanical placement)

Joint spacing shall be normal to centerline.

The pavement shall be placed and consolidated to full depth prior to insertion of the dowel bars.

The dowel bars shall be coated with a bond breaking agent prior to insertion into the plastic concrete.

The dowel bars shall be inserted into the plastic concrete ahead of the finishing beam or screed.

The installing device shall consolidate the concrete around the dowel bars such that no voids exist, without the supplemental use of hand held vibrators.

The dowel bars shall be located within 25 mm of the planned transverse location and within the range of depth of  $D/2 \pm 0.1 D$  measured from mid depth and mid length of the bar where D represents the pavement thickness.

The dowel bars shall be located within 50 mm of the planned longitudinal location.

The dowel bars shall be parallel to the pavement surface and centerline within a tolerance of 13 mm in 450 mm in both the vertical and horizontal direction.

The forward movement of the finishing beam or screed shall not be interrupted by the inserting of the dowel bars.

A positive method of marking the locations of the transverse joints shall be provided.

Drawn By: \$USER\$ Plotted: \$\$\$\$SYTIME\$\$\$\$  
File: \$\$\$\$SYTIME\$\$\$\$

NO.	DATE	REVISIONS	BY	APP'D
3				
2	5-5-04	Revison on Epoxy coating	S.W.K.	J.O.B.
1	4-9-03	Rev. General Note on Epoxy coating	S.W.K.	J.O.B.

KANSAS DEPARTMENT OF TRANSPORTATION

CONTRACTION & EXPANSION JT.  
DOWEL ASSEMBLIES

RD682 SI

FWHA APPROVAL	DESIGNED	DESIGN CK.	8-31-04	APP'D	QUANTITIES	TRACED	DESIGN CK.	DETAIL CK.	QUAN. CK.	TRACE CK.
				James O. Brewer						