

STATE	PROJECT NO.	YEAR	SHEET NO.	TOTAL SHEETS
KANSAS	87 N-0361-01	2011	101	169

**MKEC**  
ENGINEERING  
CONSULTANTS, INC.  
411 N. WEBB ROAD  
WICHITA, K.S. 67206  
316-684-9600

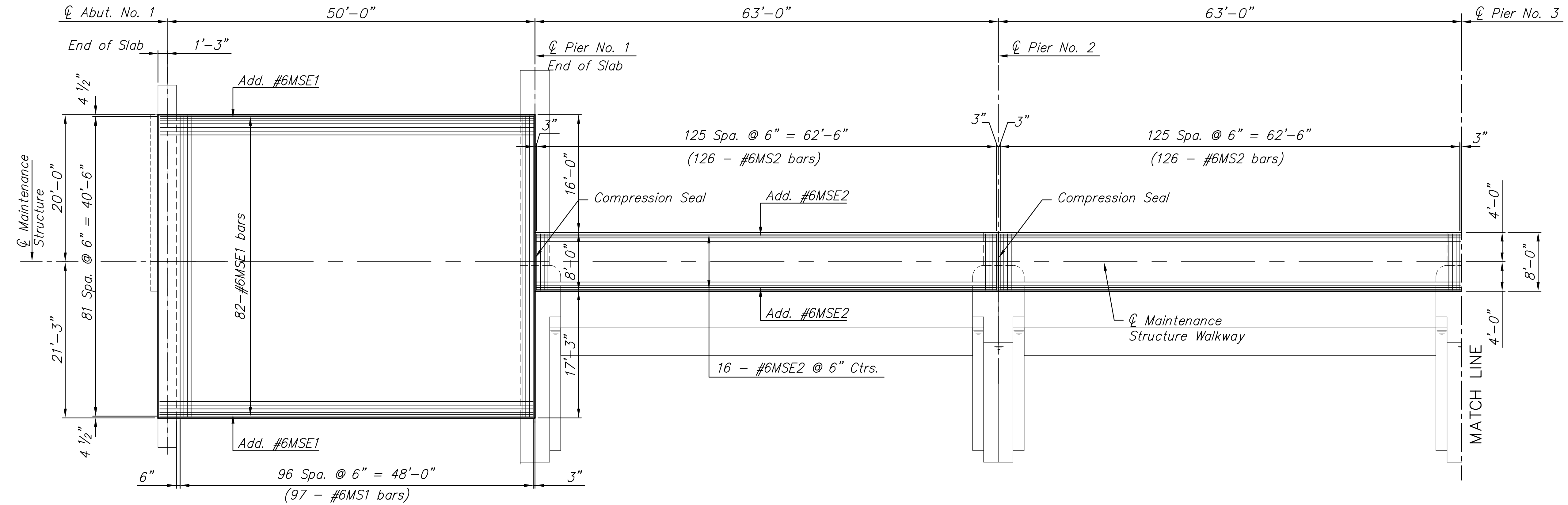

HALF PLAN  
SCALE: 1/8" = 1'-0"

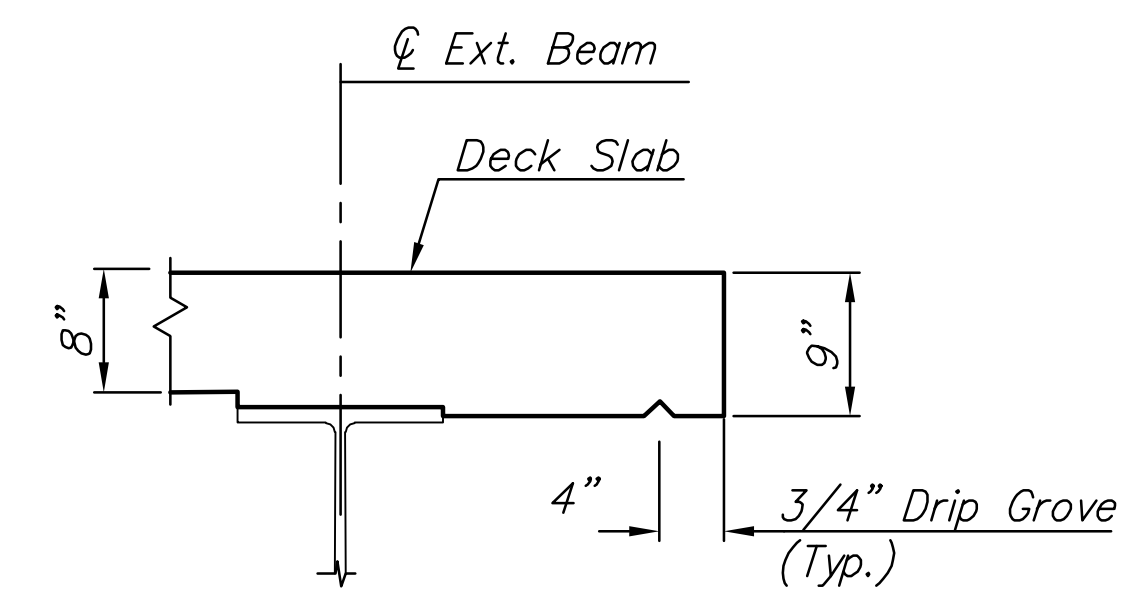

TYPICAL OVERHANG DETAILS

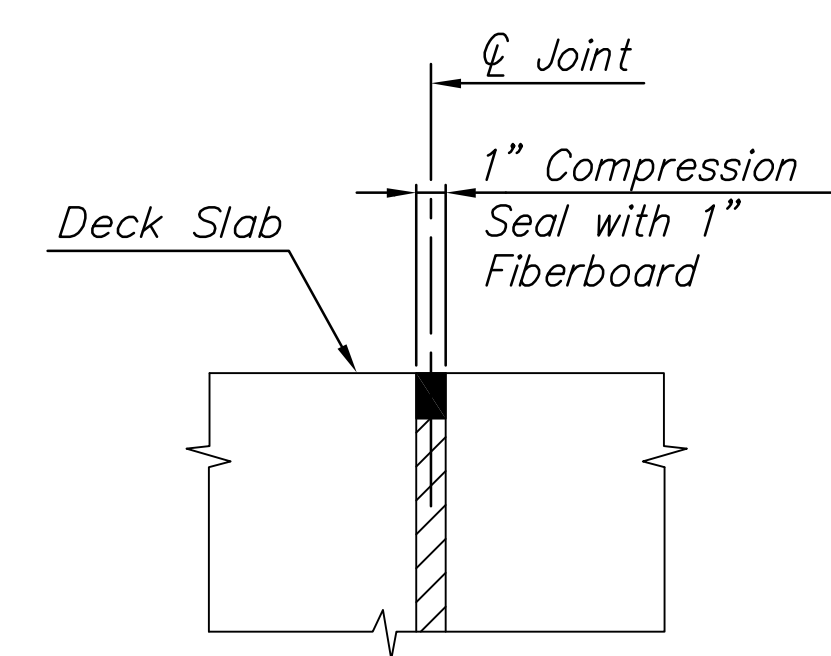

CONSTRUCTION JOINT AND  
COMPRESSION SEAL DETAIL

Brush blast, power wash and water soak surface immediately prior to casting (subsidiary).

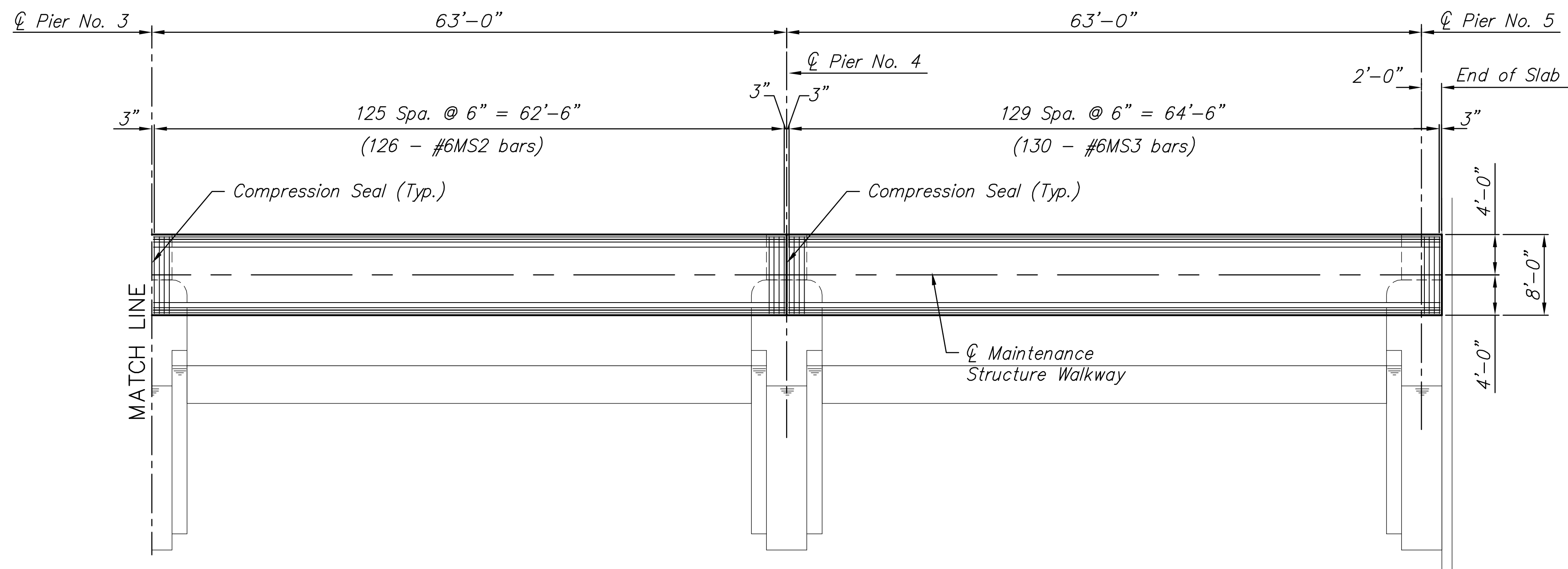

HALF PLAN  
SCALE: 1/8" = 1'-0"

**LINCOLN STREET BRIDGE AND  
DAM IMPROVEMENTS OVER  
ARKANSAS RIVER**

**MAINTENANCE  
STRUCTURE  
SLAB  
DETAILS**  
SHEET TITLE  
472-84883  
PROJECT NUMBER

DESIGN BY: JAG  
DRAWN BY: DPG  
CHECKED BY: KJS

ISSUED: 1/24/2011  
REVISED:

SHEET NO.  
**101 of 169**

PLOTTED: Tuesday, January 25, 2011 @ 08:41AM

J:\CIVIL\07433\DWG\DA\PLANS\07433 MAINT BR SLAB PLAN.DWG