

| | | | | |
|--------|-------------|------|-----------|--------------|
| STATE | PROJECT NO. | YEAR | SHEET NO. | TOTAL SHEETS |
| KANSAS | 468-84636 | 2011 | 7 | 63 |

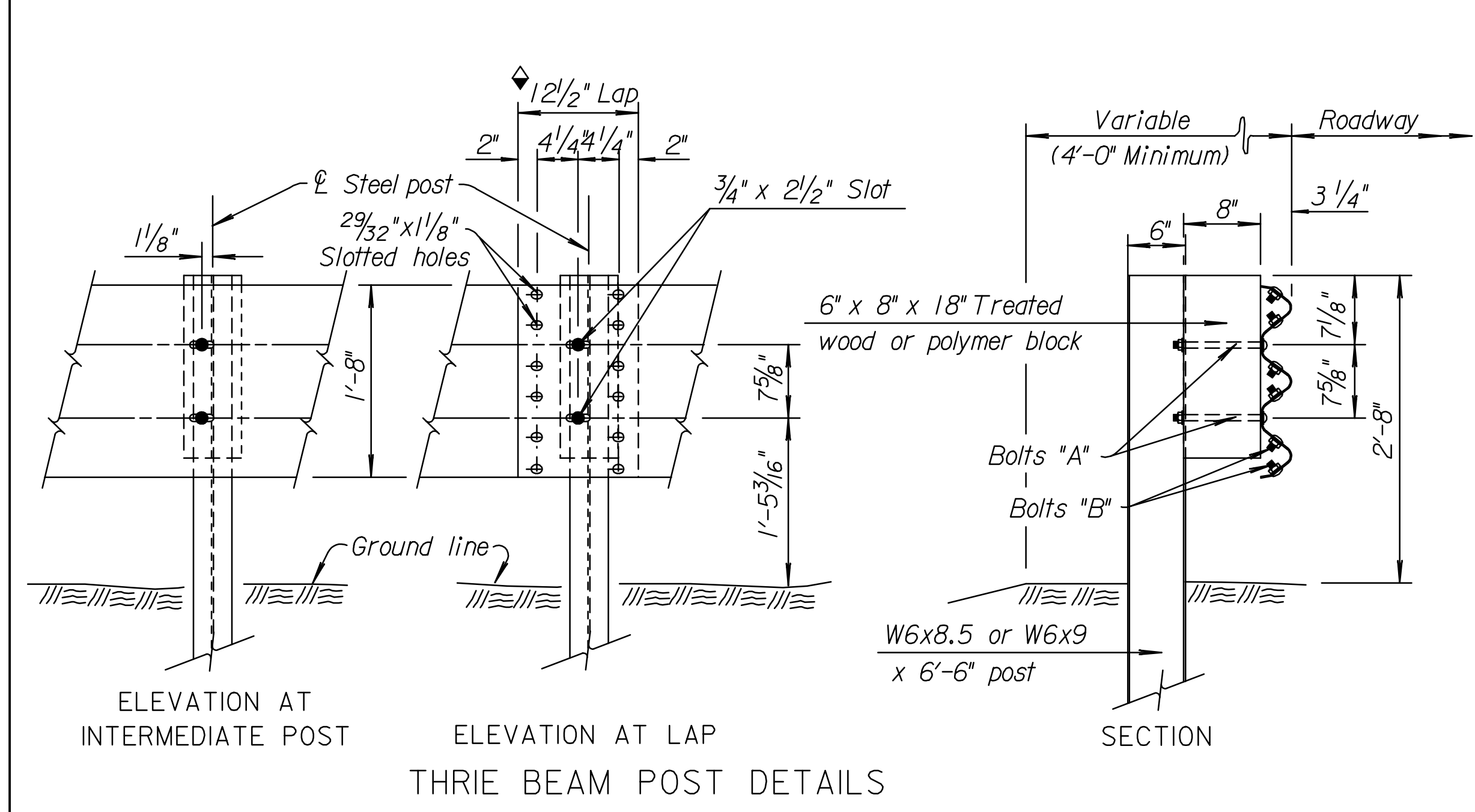

See Standard Drawing RD613 for Thrie Beam Transition Section Blockout hole pattern.

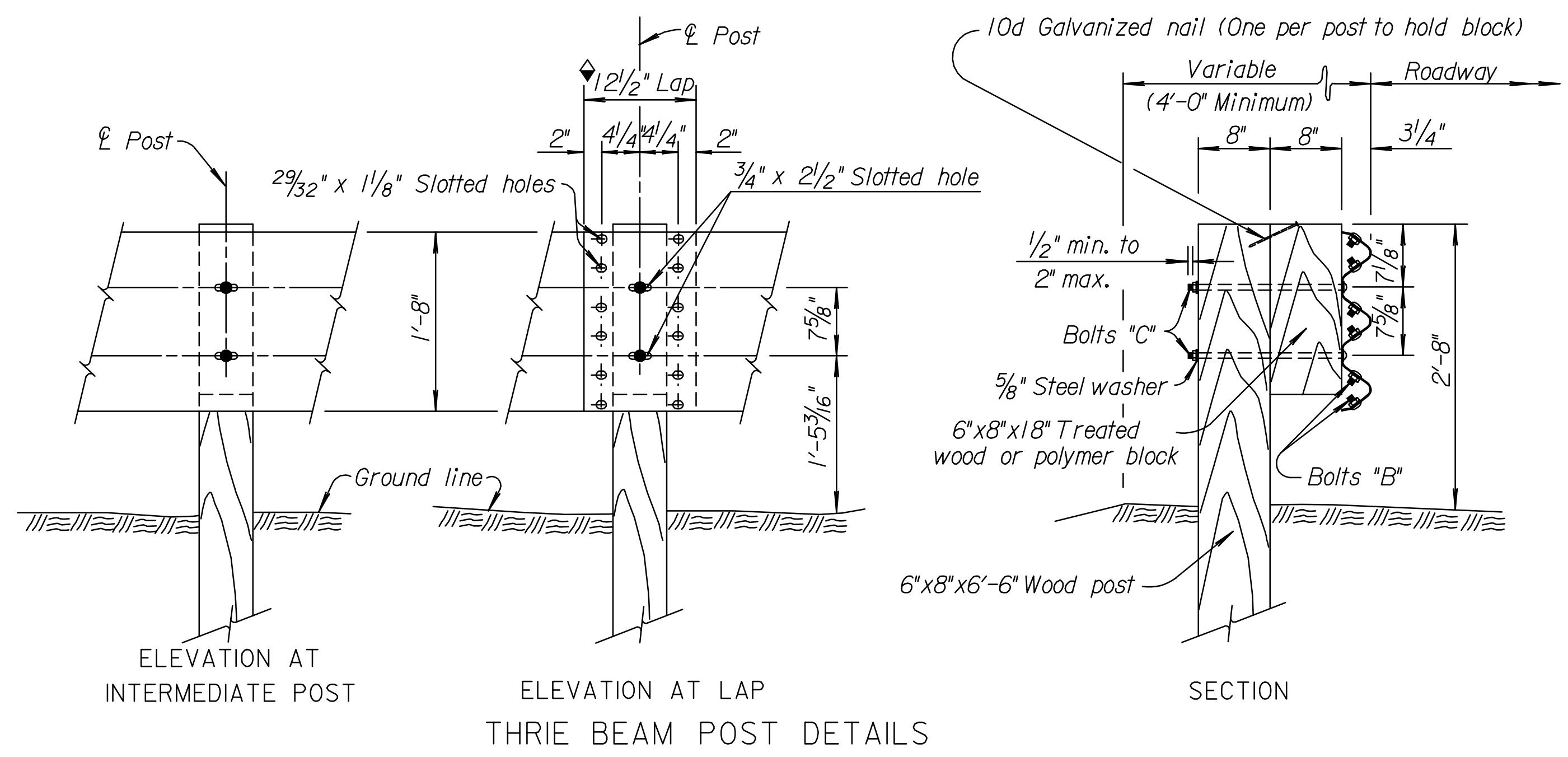
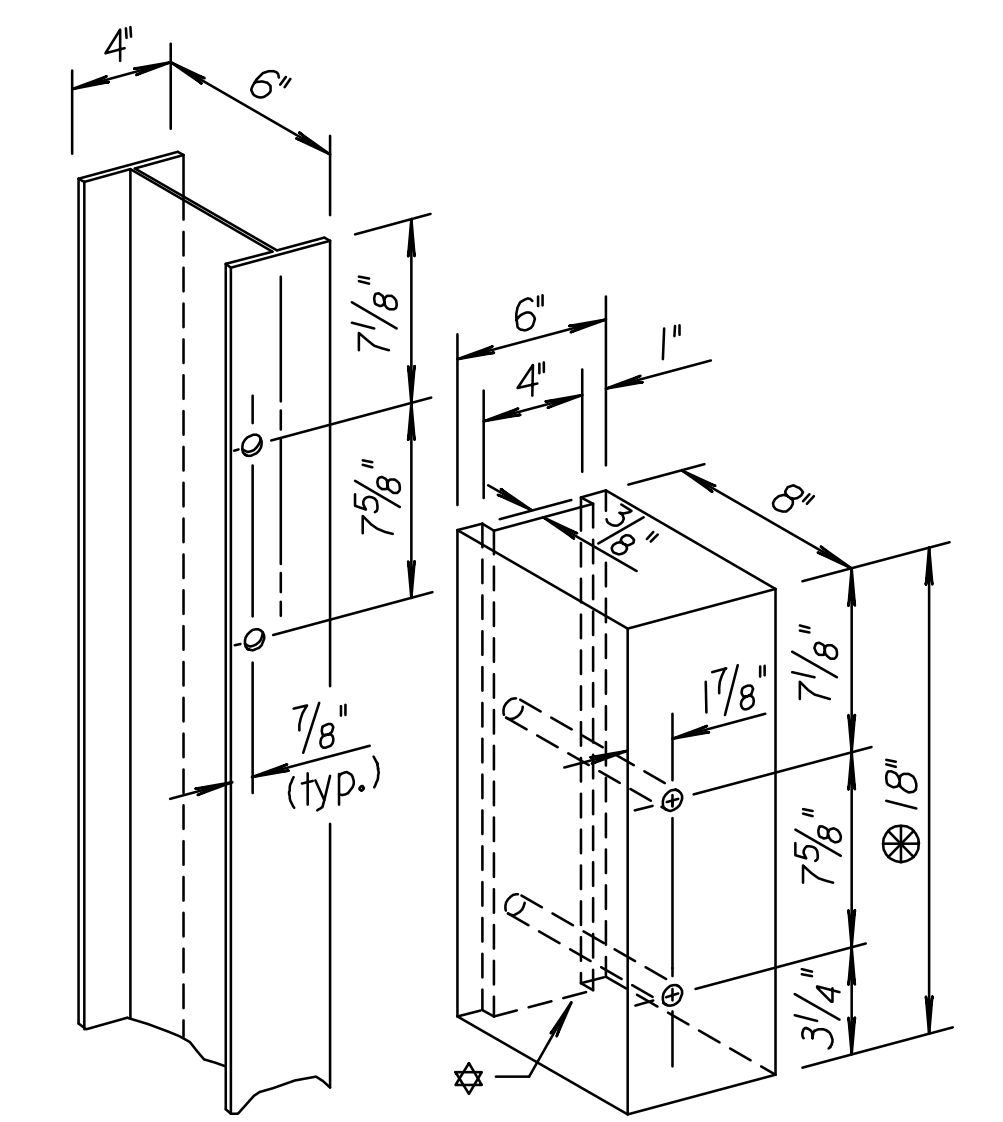

Note: All holes 13/16\"/>

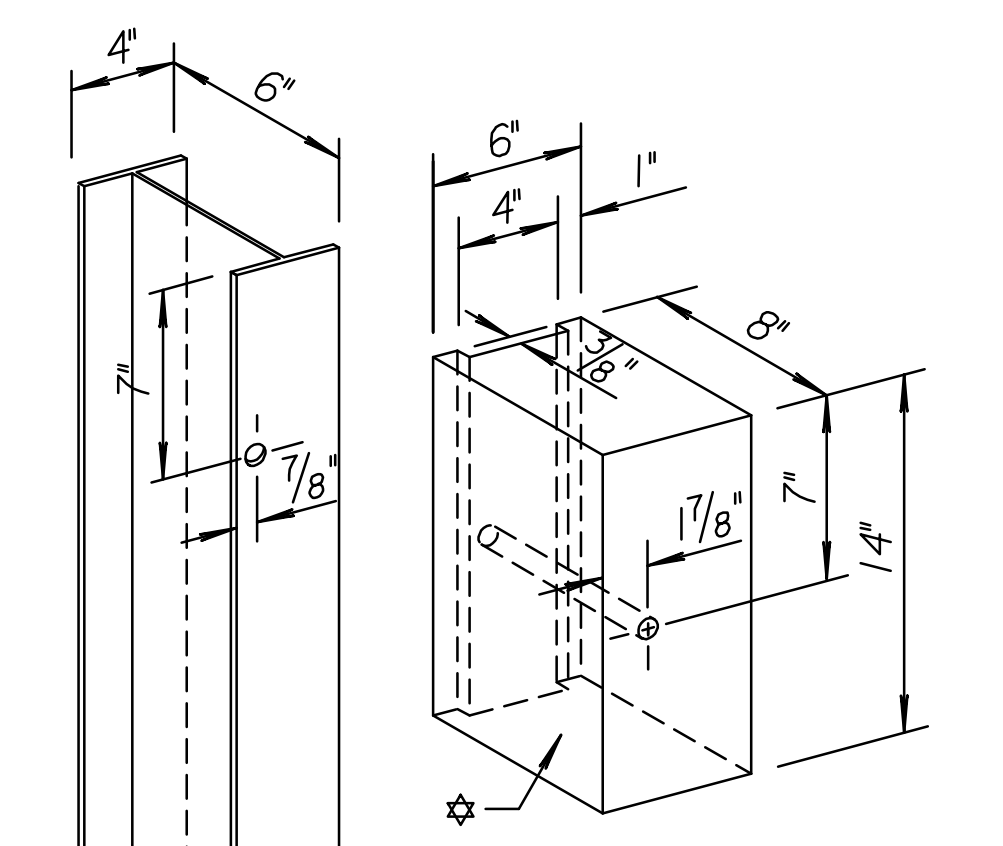
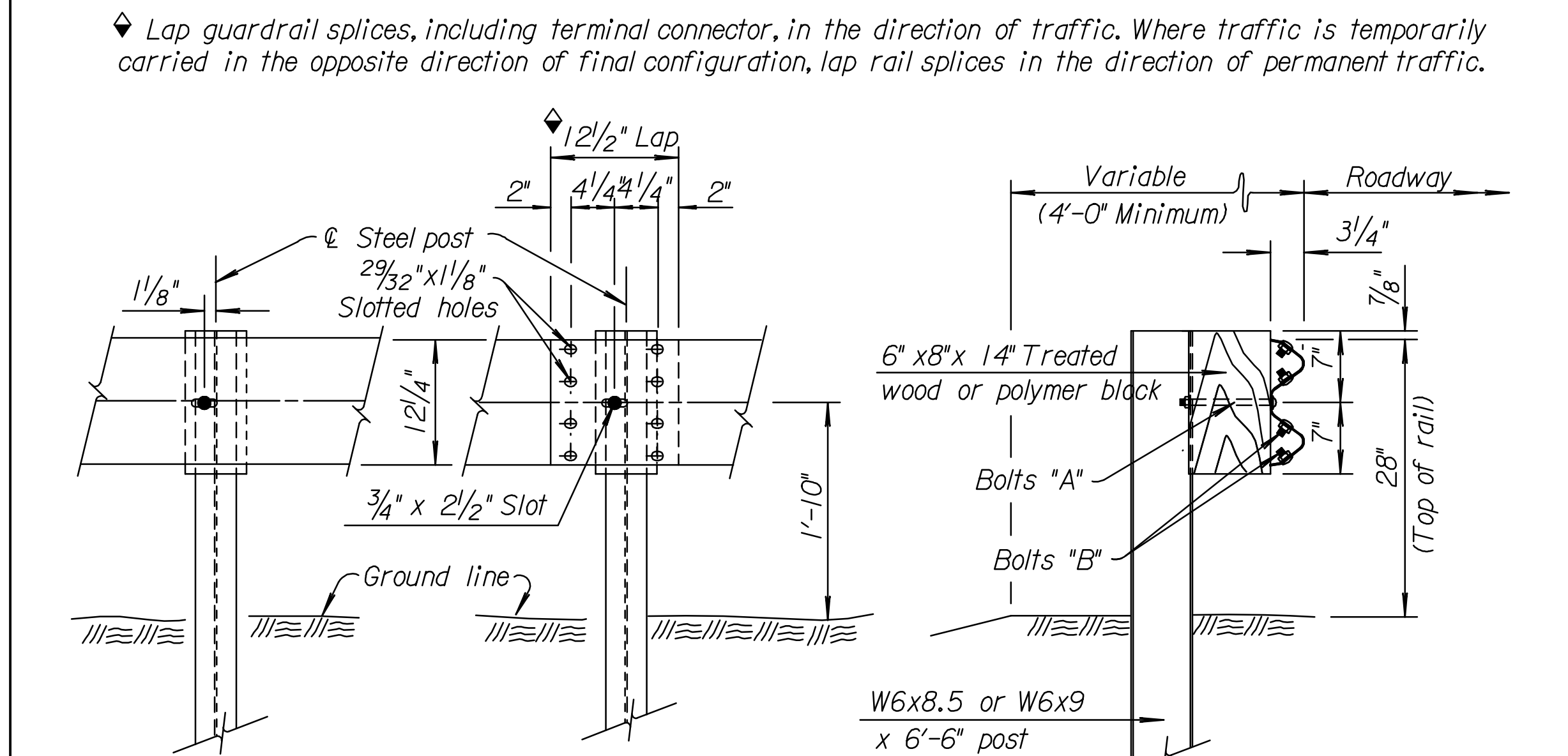
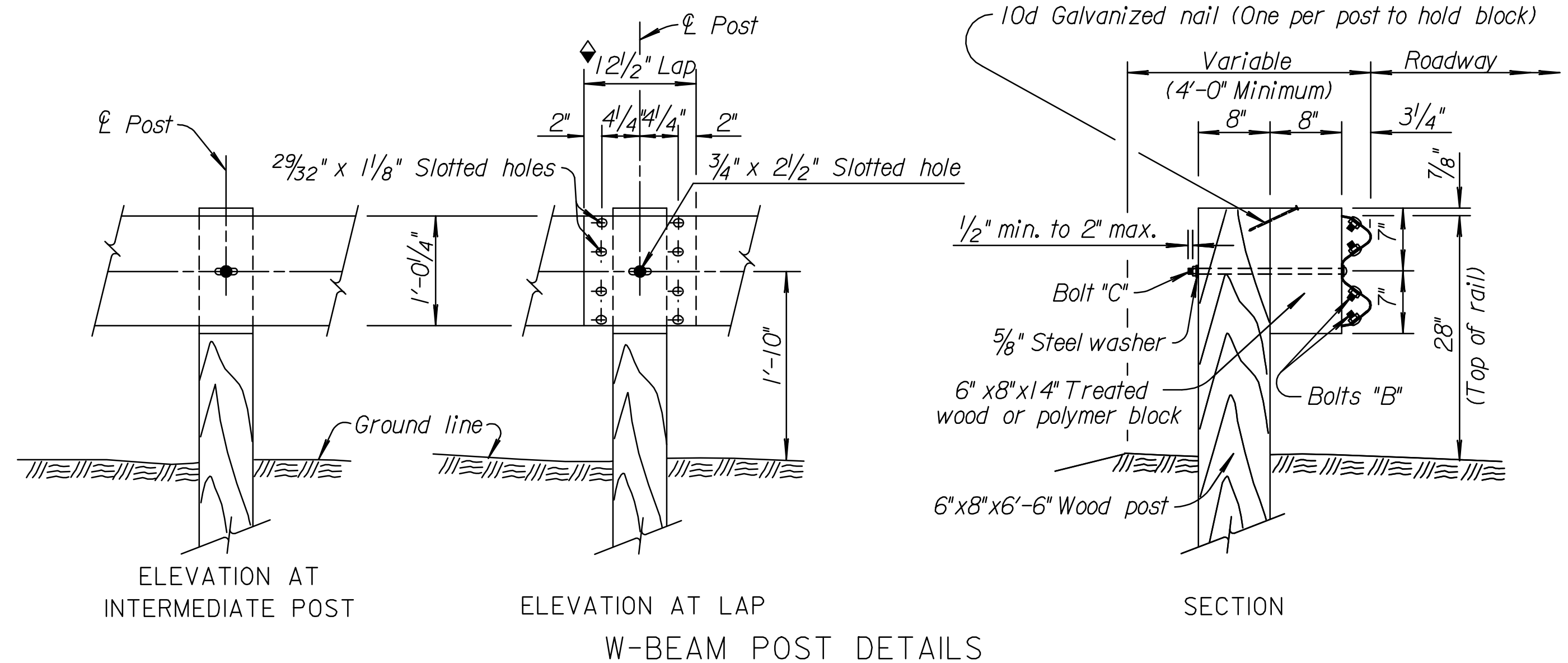

Note: All holes 13/16\"/>

Lap guardrail splices, including terminal connector, in the direction of traffic. Where traffic is temporarily carried in the opposite direction of final configuration, lap rail splices in the direction of permanent traffic.

Lap guardrail splices, including terminal connector, in the direction of traffic. Where traffic is temporarily carried in the opposite direction of final configuration, lap rail splices in the direction of permanent traffic.

WOOD POSTS

STEEL POSTS

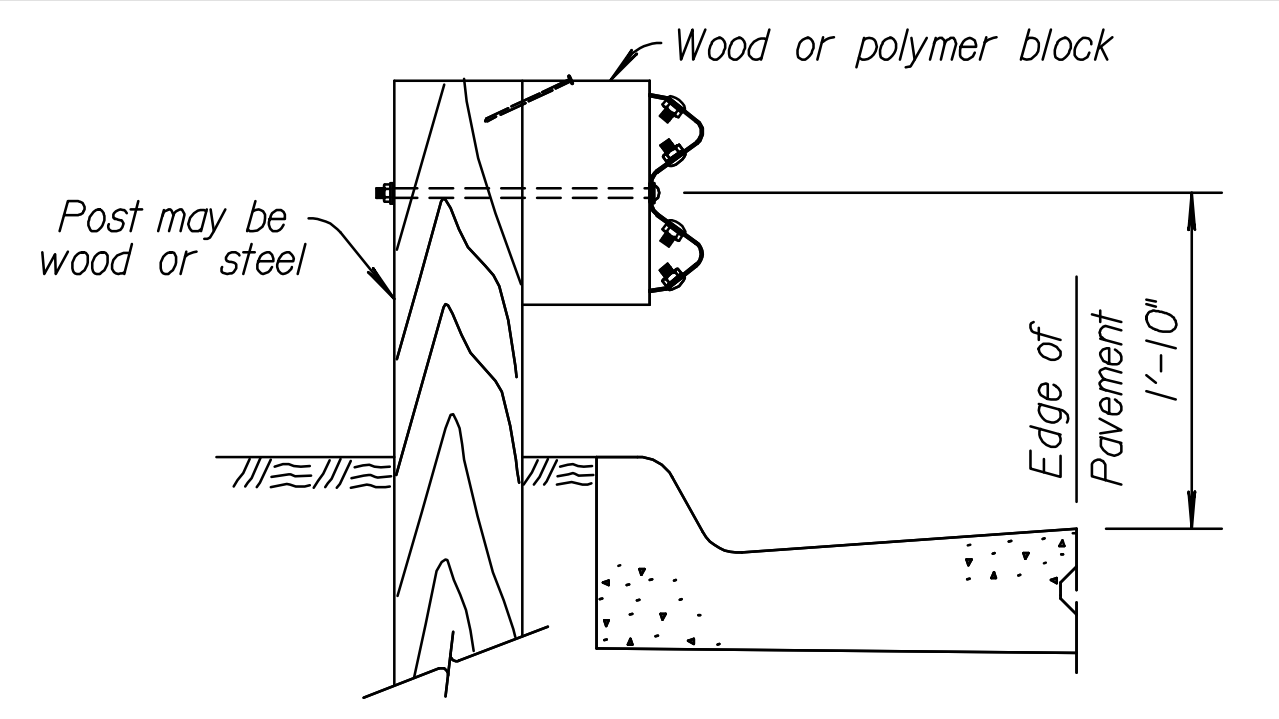

Note: When face of guardrail is aligned with the face of a curb, measure the height of rail from the pavement surface at the curb/pavement joint as shown. Use a laydown type curb where the face of the guardrail is not located at the face of the curb.

GENERAL NOTES (Wood Posts)
 Give all wood posts and wood blocks a preservative treatment, see standard specifications. Thoroughly saturate all cuts, injuries and bolt holes on wood posts and blocks with preservative. Use only one type of preservative treatment on a project. Use S4S rectangular posts and wood blocks, see standard specifications. Use only one post/blockout type within guardrail run, this excludes the the guardrail end terminals.
 Set guardrail posts by digging or by driving. Use post caps to protect the post from crushing during driving operations.
 Excavation including rock, shale and other materials for erection of guardrail is considered subsidiary to the various bid items for which payment is made. Contractor must notify Engineer at the earliest time when a non-removable man-made object (footing, pipe, etc.) is encountered and prevents installation of a full length post. Contractor must obtain Engineer approval prior to cutting post shorter than 6'-0\"/>

Galvanize all bolts, nuts, and washers in accordance with the standard specifications.

| BOLT SIZE SCHEDULE | |
|--------------------|--------|
| Bolt | L |
| A | 8 1/2" |
| B | 1 1/4" |
| C | 18" |

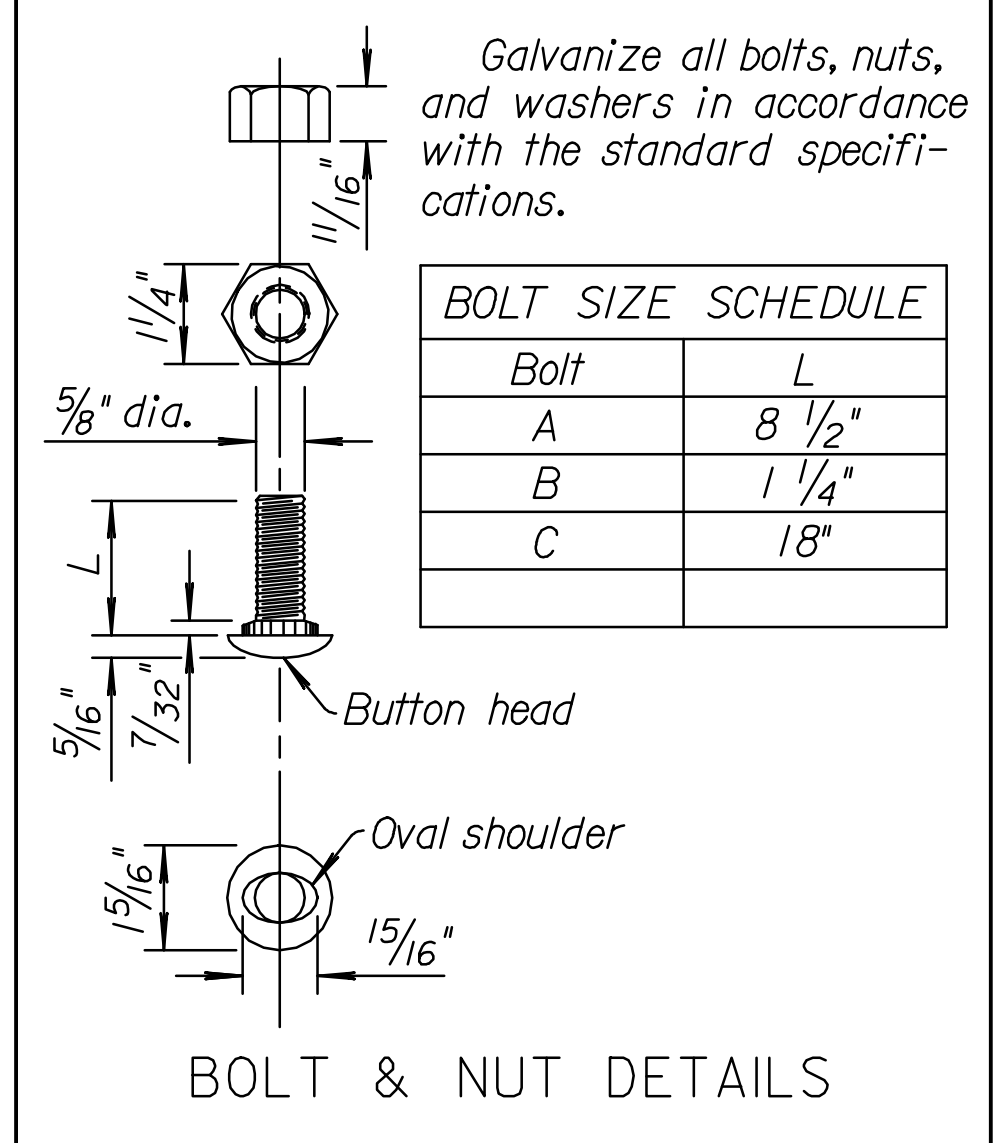

GENERAL NOTES (Steel Posts)
 Use grade of steel for steel posts that meets the requirements of the standard specifications.
 Hot dip galvanize the posts after fabrication, see standard specifications.
 Use only one post/blockout type within guardrail run, this excludes the guardrail end terminals. For wood/polymer blockout requirements see standard specifications. Approved polymer blockouts may be substituted for wood blockouts. Only one type of blockout is permitted on each guardrail installation. This excludes the guardrail end terminals.
 Set guardrail posts by digging or by driving. Use post caps to protect the post from crushing during driving operations.
 Contractor must notify Engineer at the earliest time when a non-removable man-made object (footing, pipe, etc.) is encountered and prevents installation of a full length post. Contractor must obtain Engineer approval prior to cutting post shorter than 6'-6\"/>

NON-METALLIC (POLYMER) or TREATED WOOD BLOCK

| NO. | DATE | REVISIONS | BY | APP'D |
|-----|----------|---------------------------------|--------|--------|
| 12 | 12-14-10 | Revised notes, 28\"/> | S.W.K. | J.O.B. |
| 11 | 6-30-04 | Remove steel blockout and notes | S.W.K. | J.O.B. |
| 10 | 7-15-02 | Add polymer block-out alternate | S.W.K. | J.O.B. |

KANSAS DEPARTMENT OF TRANSPORTATION

GUARDRAIL POST DETAILS

RD611

| | | | |
|---------------|------------|------------|-----------------|
| FHWA APPROVAL | I-11-11 | APP'D. | James O. Brewer |
| DESIGNED | DETAILED | QUANTITIES | TRACED |
| DESIGN CK. | DETAIL CK. | QUAN. CK. | TRACE CK. |