

CONSTRUCTION PLAN FOR PRIVATE WATER DISTRIBUTION SYSTEM IMPROVEMENTS

KIA ADDITION

TO

THE CITY OF WICHITA, KANSAS

GARY JANZEN, P.E. - CITY ENGINEER

1708 PPW OCA NO. 607853

General Notes

- Contractor will be required to provide notice to utility companies a minimum of seventy-two (72) hours prior to any excavation, as follows:

Kansas One-Call 687-2470

The Contractor must notify the following in case of an emergency:

Cox Communications (Cable) 262-0661
 Westar Energy (Electric) 261-6512
 Kansas Gas Service (Gas) 832-3101
 AT&T (Telephone) 1-800-870-8390
 City of Wichita Water & Sewer 262-6000
 Black Hills Energy 1-800-303-0357

- All water mains and appurtenances shall be installed in accordance with City of Wichita, Kansas Standard Specifications for Water Main Installations No. 14533.
- The water main shall be constructed on the alignment shown by the plans. Trees and shrubs in public right-of-way or private easements which are in direct conflict with proposed new construction shall be removed by the Contractor with the Engineer's approval. Trees and shrubs which are not in direct conflict with proposed new construction shall be saved and protected from damage. The cost for any necessary tree trimming, clearing and/or grubbing shall be included in the price bid for the installed water main pipe.
- Opening and closing of water valves shall be done slowly to prevent damage to the water distribution system from water hammer. All valves closed by the contractor must be reopened as new construction permits. Project inspector must ascertain that any valve closed by the contractor is reopened. Contractor will be permitted to operate water valves only when the project inspector assigned to the project is present.
- Contractor shall not start work on the project until the project inspector is assigned to the project and is present on the site. Any work done without inspection will be required to be uncovered for inspection.
- Underground utility service lines and overhead utility pole lines are to be adjusted as necessary by others prior to construction, unless the plans specifically call for their adjustment by the Contractor. Existing utilities and their locations, as shown on the plans, represent the best information obtainable for design. Location information has been obtained from the various utility companies and is either from company record drawings or company-provided field locations. The Contractor will be required to work around existing utilities within the right-of-way which do not conflict with proposed construction.
- The Contractor shall give all property owners and/or tenants of developed property directly abutting the construction of this project a minimum of ten (10) days notice prior to start of construction.
- The Contractor shall be responsible for preserving property irons. The Contractor will be required to re-establish any property irons which are damaged or destroyed by his construction operations. Such irons shall be re-established by a licensed land surveyor in accordance with state law.
- The Contractor shall be responsible for all testing, inspection, staking, and other work as necessary to complete the project.

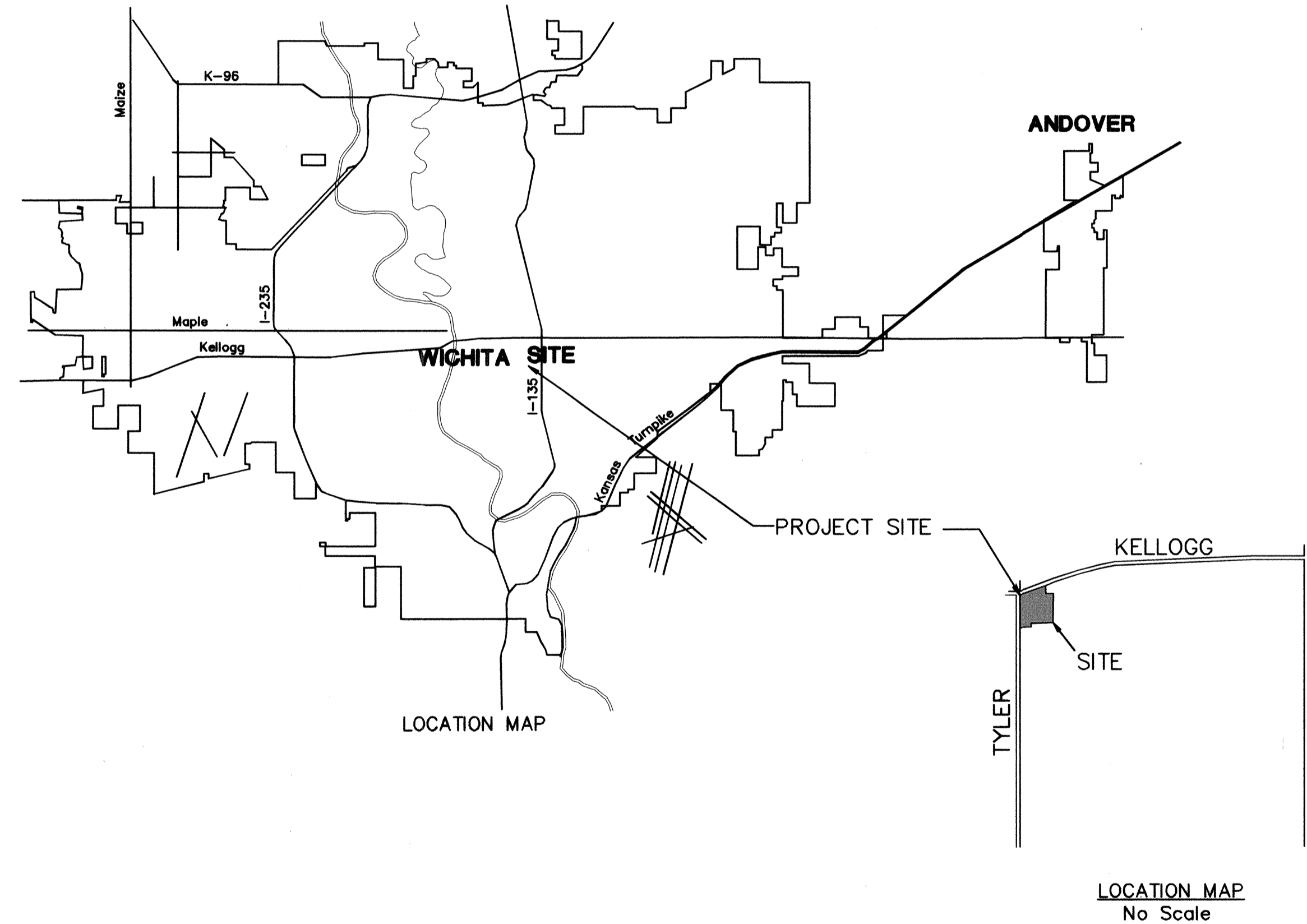
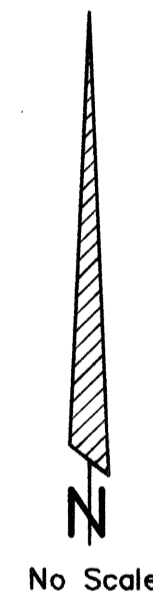

INDEX OF SHEETS

SHEET NO.	TITLE SHEET
1	KEY MAP
2	STANDARD DETAILS
3	PLAN PROFILE
4	MISCELLANEOUS DETAILS
5-5A	EROSION CONTROL
6-10	PLAT
11	

APPROVED AS NOTED
 BY CITY ENGINEER OF WICHITA,
 BY WICHITA WATER & SEWER DEPARTMENT,
 & BY WICHITA FIRE DEPARTMENT

Public Works *Julian Hallman 2-12-13*
 Water & Sewer *Angela 2-12-13*
 Fire *Ron Simpson 2-13-2013*

NOTE TO CONTRACTORS
Public Property:
 Inspection and testing for the waterline is to be provided by a Licensed Consulting Engineering Firm under contract with the Owner/Developer. Said inspection to be in accordance with the City of Wichita standard construction engineering practices and certified by a Professional Engineer Licensed in the state of Kansas. No work shall be performed in dedicated easements or public right-of-way by the Contractor without such inspection nor shall any work be commenced without written authorization by the City Engineer. All Construction and Materials shall comply with the City or Wichita Specifications and Standards (on file and available in the City Engineer's Office).

Private Property:
 Installation and testing for the fire protection line is to be performed by a City of Wichita licensed fire protection contractor in accordance with the fire codes as adopted by the City of Wichita. All material and construction practices for the fire protection line shall comply with the fire codes as adopted by the City of Wichita (available from the City of Wichita Fire Department). The Contractor shall not commence work without notification and approval of the Wichita Fire Department. Inspection of the fire protection line is to be provided by a licensed Engineering Firm under contract with the Owner/Developer and the Fire Department. The contractor shall not start work until the project inspector is assigned to the project and present on the site. Any work done without inspection will be required to be uncovered for inspection.

NOVEMBER 2012
 PLANS PREPARED BY



POE & ASSOCIATES, INC.
 CONSULTING ENGINEERS
 5940 E. Central, Suite 200 ■ Wichita, KS 67208-4242
 Phone 316/685-4114 ■ FAX 316/685-4444

KIA ADDITION
 KELLOGG & TYLER
 WATER DISTRIBUTION SYSTEM IMPROVEMENTS
 CITY OF WICHITA, KANSAS
 GARY JANZEN, P.E. - CITY ENGINEER
 C.D.M. Proj.# 1708 PPW O.C.A.# 607853

POE & ASSOCIATES, INC.
 CONSULTING ENGINEERS
 5940 E. Central, Suite 200 ■ Wichita, KS 67208-4242
 Phone 316/685-4114 ■ FAX 316/685-4444

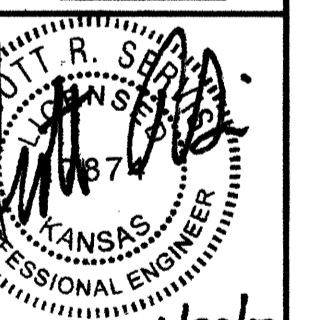

11/20/12

Engineer: S. SERVIS
 Designer: S. SERVIS
 Drawing: P:\102020\Bases\SWL.dwg
 Date: 2/12/2013

NOTE:
Waterline Valves to be operated by Contractor ONLY if THE PROJECT INSPECTOR is ON SITE.

Contractor to Field Verify Location of all Existing Utilities Prior to Construction.

LEGEND

EXISTING WATER MAIN	
PROPOSED WATER MAIN	
EXISTING WATER VALVE	
PROPOSED WATER VALVE	
EXISTING FIRE HYDRANT	
PROPOSED FIRE HYDRANT	
PROPOSED BLOW OFF VALVE	

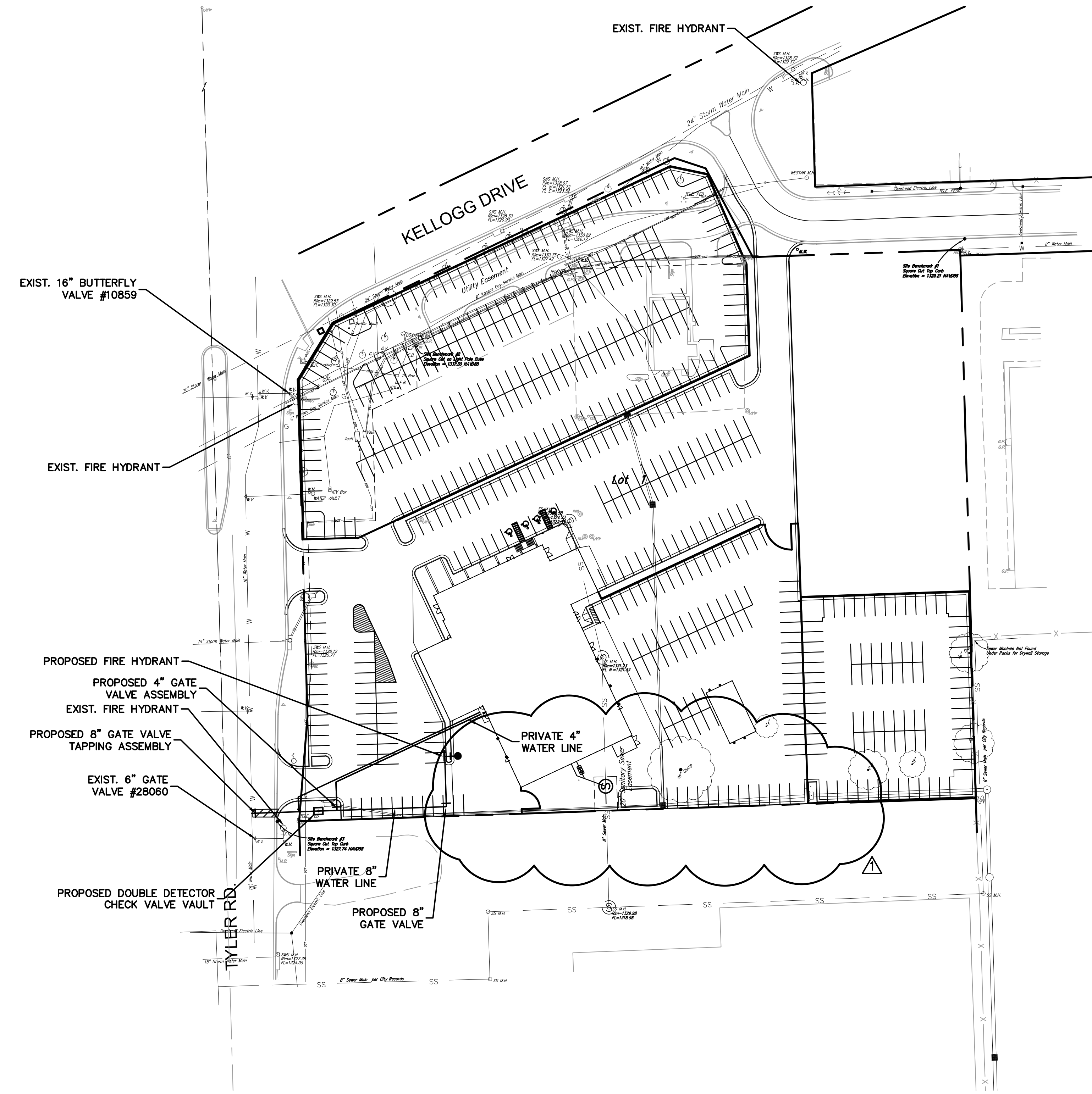
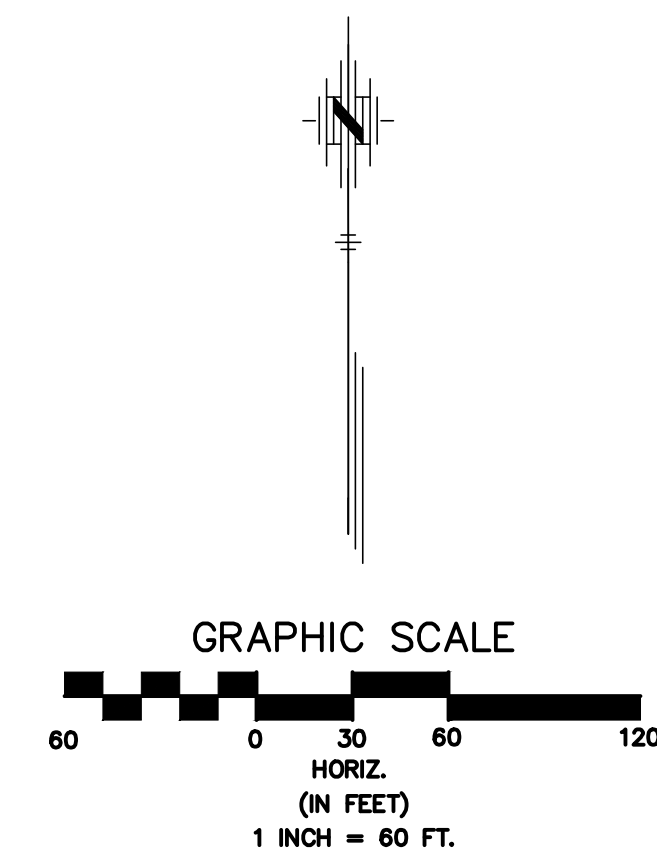

BENCH MARKS

1. Cut on Top of Curb 10' N & 4' E of the NE Corner of Property. Elev.=1329.21
2. Cut on Light Pole Base 109' NE of the NW Corner of Property. Elev.=1331.30
3. Cut on Top of Curb 19.5' W of the SW Corner of Property. Elev.=1327.74

1-22-13	MLT	SRS	Removed East End of Line 1
<p>KIA ADDITION KELLOGG & TYLER WATER DISTRIBUTION SYSTEM IMPROVEMENTS WATER LINE KEY MAP CITY OF WICHITA, KANSAS GARY JANZEN, P.E. - CITY ENGINEER C.O.M. Proj.# 1708 PFW O.C.A.# 607853</p>			
<p>POE & ASSOCIATES, INC. CONSULTING ENGINEERS 5940 E. Central, Suite 200 • Wichita, KS 67208-4242 Phone 316/685-1114 • FAX 316/685-4444</p>			
11/20/12			
<p>FINAL</p>			
<p>Engineer: S. SERVIS Designer: S. SERVIS Drawing: P:\102020\BaseSWL.dwg Date: 1/22/2013</p>			
Sheet 2 of 11			

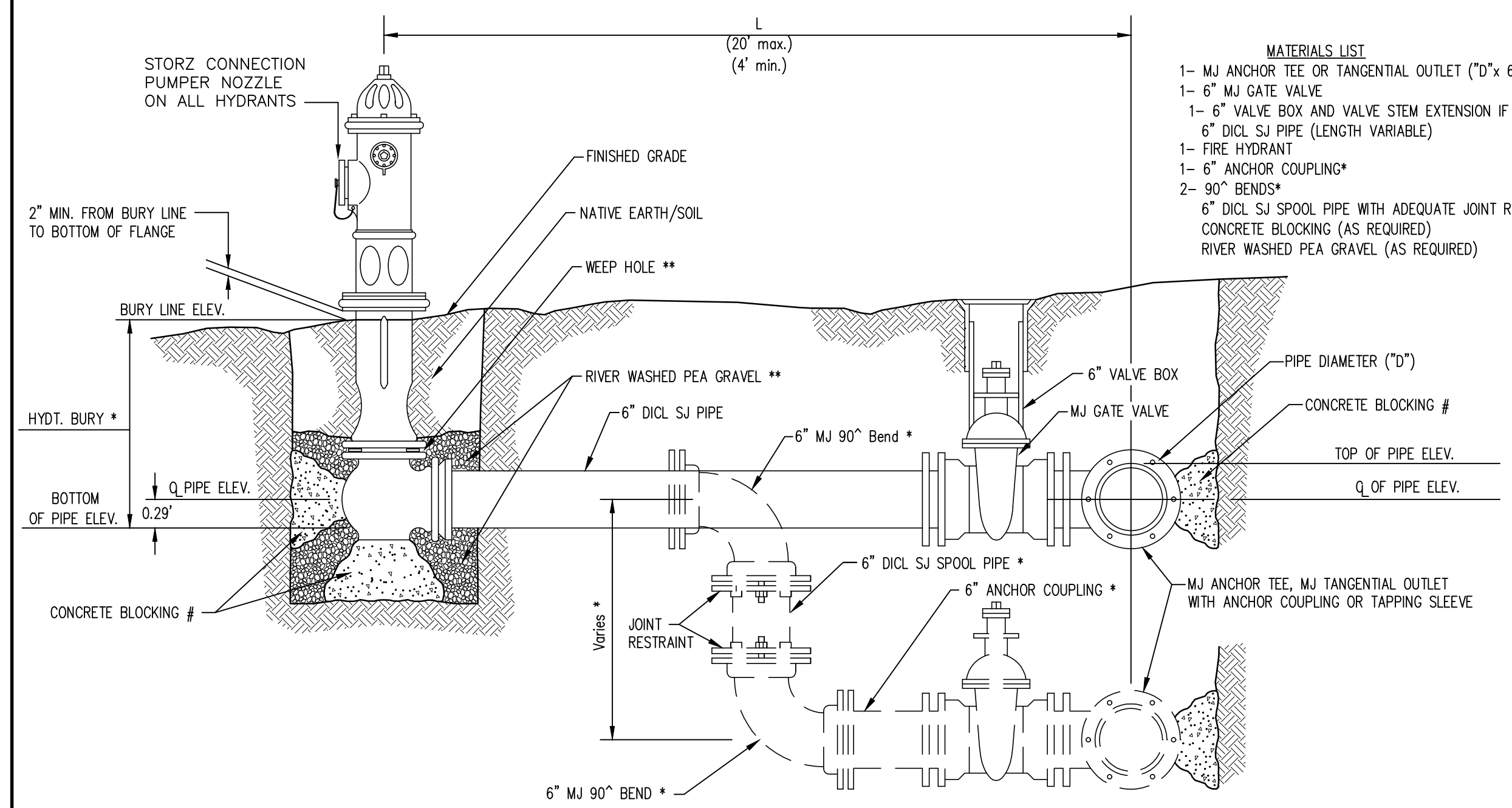

- MATERIALS LIST**
- 1- MJ ANCHOR TEE OR TANGENTIAL OUTLET ("D"x 6")
 - 1- 6" MJ GATE VALVE
 - 1- 6" VALVE BOX AND VALVE STEM EXTENSION IF REQUIRED *
 - 6" DI CL SJ PIPE (LENGTH VARIABLE)
 - 1- FIRE HYDRANT
 - 1- 6" ANCHOR COUPLING*
 - 2- 90° BENDS*
 - 6" DI CL SJ SPOOL PIPE WITH ADEQUATE JOINT RESTRAINT *
 - CONCRETE BLOCKING (AS REQUIRED)
 - RIVER WASHED PEA GRAVEL (AS REQUIRED)

* IF THE REQUIRED HYDRANT BURY IS IN EXCESS OF 5', BUT LESS THAN 7', CONTRACTOR SHALL USE STANDARD 5' HYDRANT BURY AND HYDRANT BARREL EXTENSIONS AS NECESSARY. IF THE REQUIRED HYDRANT BURY IS GREATER THAN 7', CONTRACTOR SHALL USE 5' HYDRANT BURY, 2-MJ 90° BENDS, 6" ANCHOR COUPLING AND 6" DI CL SPOOL PIPE AS NECESSARY FOR VERTICAL ADJUSTMENT. THE CONTRACTOR SHALL PROVIDE ADEQUATE THRUST BLOCKING AT HYDRANT AND MEGALUGS, ROD AND LUG OR SIMILAR RESTRAINT BETWEEN 90° BENDS TO SECURE ALL FITTINGS DURING TESTING AND OPERATION. THE CONTRACTOR SHALL PROVIDE A VALVE STEM EXTENSION PER DETAIL THIS SHEET.

** CAUTION: WEEP HOLES TO BE KEPT CLEAR DURING CONSTRUCTION AND BACKFILL. CONCRETE FOR THRUST BLOCKING SHALL NOT OBSTRUCT WEEP HOLES. PLACE 1 CUBIC FOOT OF RIVER WASHED PEA GRAVEL AROUND EACH WEEP HOLE.

CONCRETE THRUST BLOCKING SHALL BE KEPT CLEAR OF BOLTS, NUTS, AND MJ ACCESSORIES.

FIRE HYDRANT ASSEMBLY
PER CITY OF WICHITA SPECIFICATIONS

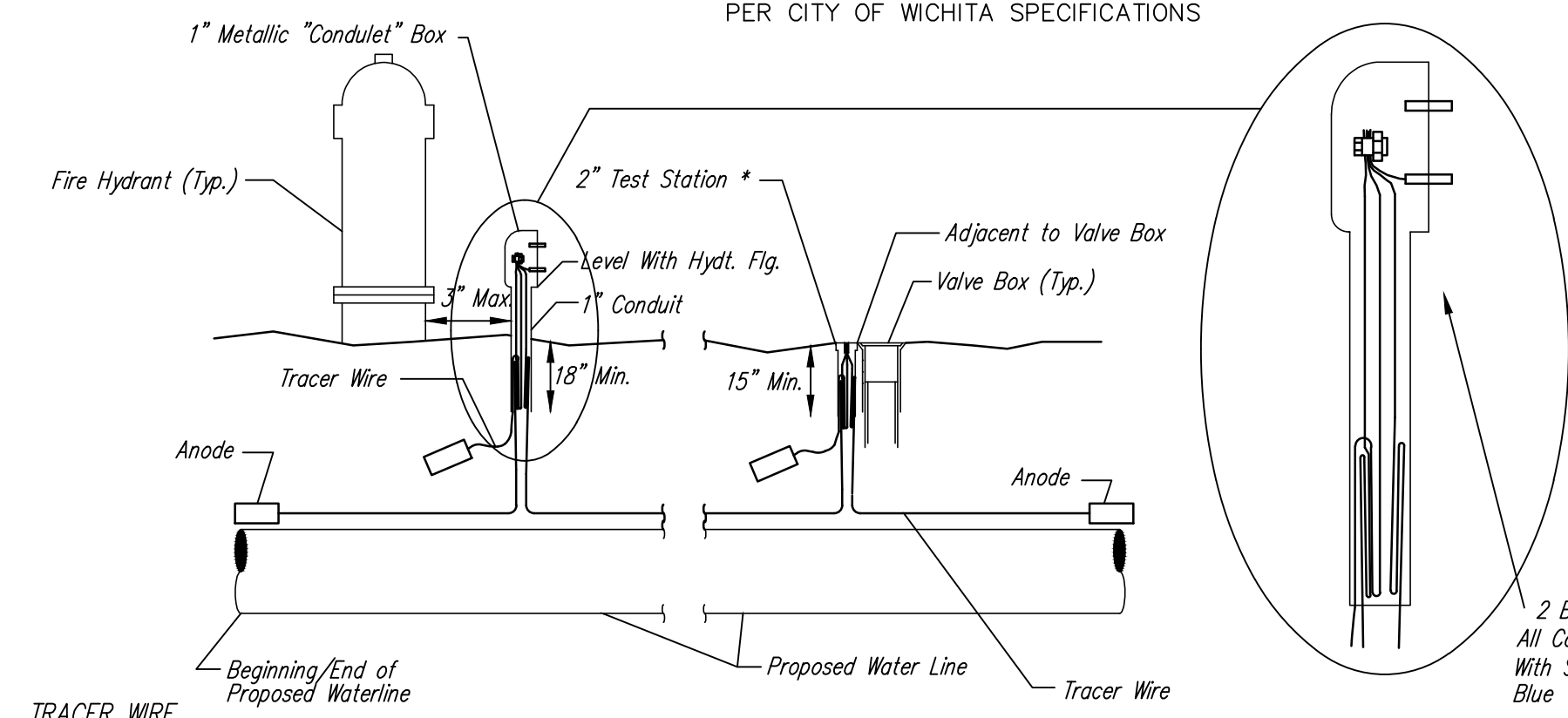

TRACER WIRE
Conductive type pipe locator/tracer wire shall be installed to locate all waterline pipe regardless of pipe material. The wire shall extend the entire length of the proposed pipe. The wire shall be taped to the waterline and pulled with the pipe. Split-bolt connectors shall be used at splice locations. Electrical tape shall cover all splices so no bare wire is exposed. Test stations shall be installed adjacent to all fire hydrants along the waterline and at blowoffs or valves near the ends of the waterlines. Any exceptions to the location of test stations shall be approved by the engineer. At each test station, the tracer wire shall be connected to a 3 lb. Zinc or magnesium anode. Anodes shall also be attached to the tracer wire at both the beginning and the end of the proposed waterline. A typical layout of the tracer wire and test station is provided in the above figure.

WIRES
The tracer wire shall be Blue No. 12 THHN annealed soft copper wire with thermal plastic insulation or Blue No. 12 AWG CCS with 30 mil HDPE insulation. The insulation shall be heat, oil, and gasoline resistant as manufactured by Temple Electric or approved equal. To allow for grade adjustment, a minimum of 12" of excess wire shall be coiled at the bottom of the test station for all wires. The insulation sheathing shall be removed such that 1" bare copper wire at all points of connection. Contractor shall attach wire being installed with proposed water main to any tracer wire installed with adjacent waterline projects.

TEST STATIONS
The test station for fire hydrant applications shall be a 1 inch galvanized "condulet" style test station as manufactured by AGRA Industries with a removable solid cover having two leads extending from the face or approved equal. The test station for valve applications shall be 2 inch flush style test station T2PS3B as manufactured by HANDLEY Industries or approved equal. The "condulet" style test station shall be attached to a 1 inch rigid galvanized conduit with a minimum length of 36" and plastic end bushing. The flush style shall have the word "WATER" stamped or molded into the lid. All test stations shall be manufactured using molded blue tops or sufficiently coated with blue enamel paint. The tracer wire and the anode wire shall be installed to allow 10 inches of wire within the test station. In concrete environments such as sidewalks or in the downtown area the contractor shall use the flush style test station. The location of all test stations shall be approved by the engineer, recorded, and shown in the as-built drawings.

ANODES
The anodes shall be 3 lb. bare zinc or magnesium. The anodes shall be buried at the same elevation as the waterline at each test station. The anodes shall be connected to Black No. 12 THHN annealed soft copper wire which shall be extended to the test station.

TRACER WIRE DETAIL
COST IS SUBSIDIARY TO PIPE INSTALLATION

FIRE HYDRANTS REQUIRED

STATION	BURY LINE ELEVATION	TOP OF PIPE ELEVATION	FIRE HYDRANT BURY REQUIRED*	VALVE STEM EXT. REQUIRED (ft)*
Line 2-0+44.32	1332.12	1327.93	5.0'	0'

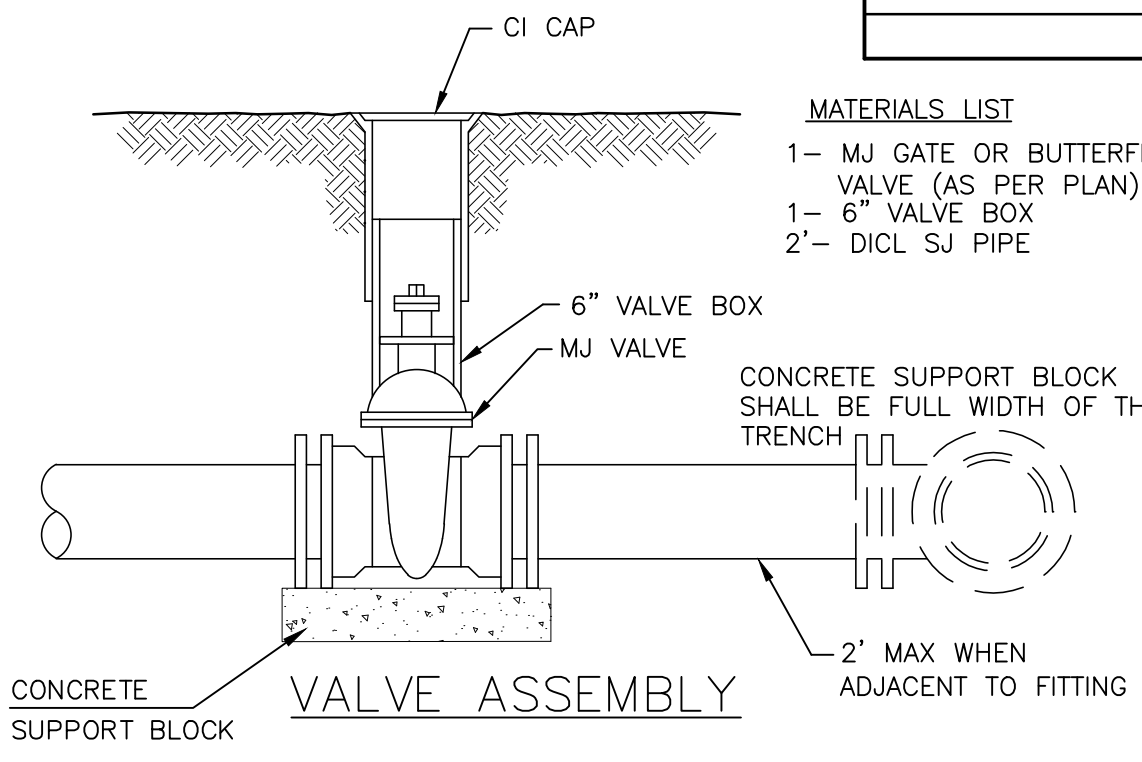

- MATERIALS LIST**
- 1- MJ GATE OR BUTTERFLY VALVE (AS PER PLAN)
 - 1- 6" VALVE BOX
 - 2'- DI CL SJ PIPE

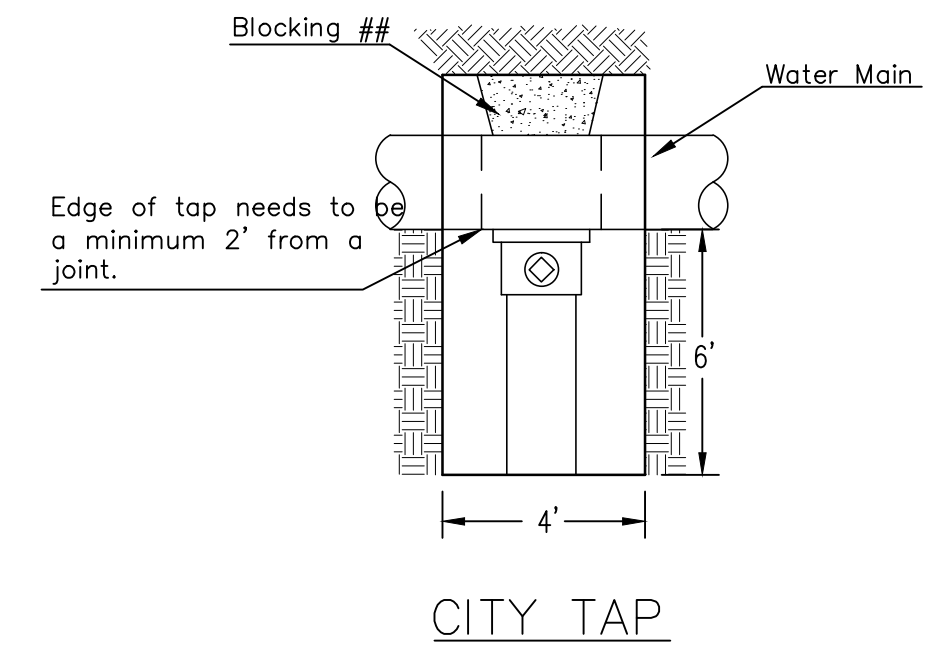

When the City of Wichita makes tap, blocking is to be done by Contractor

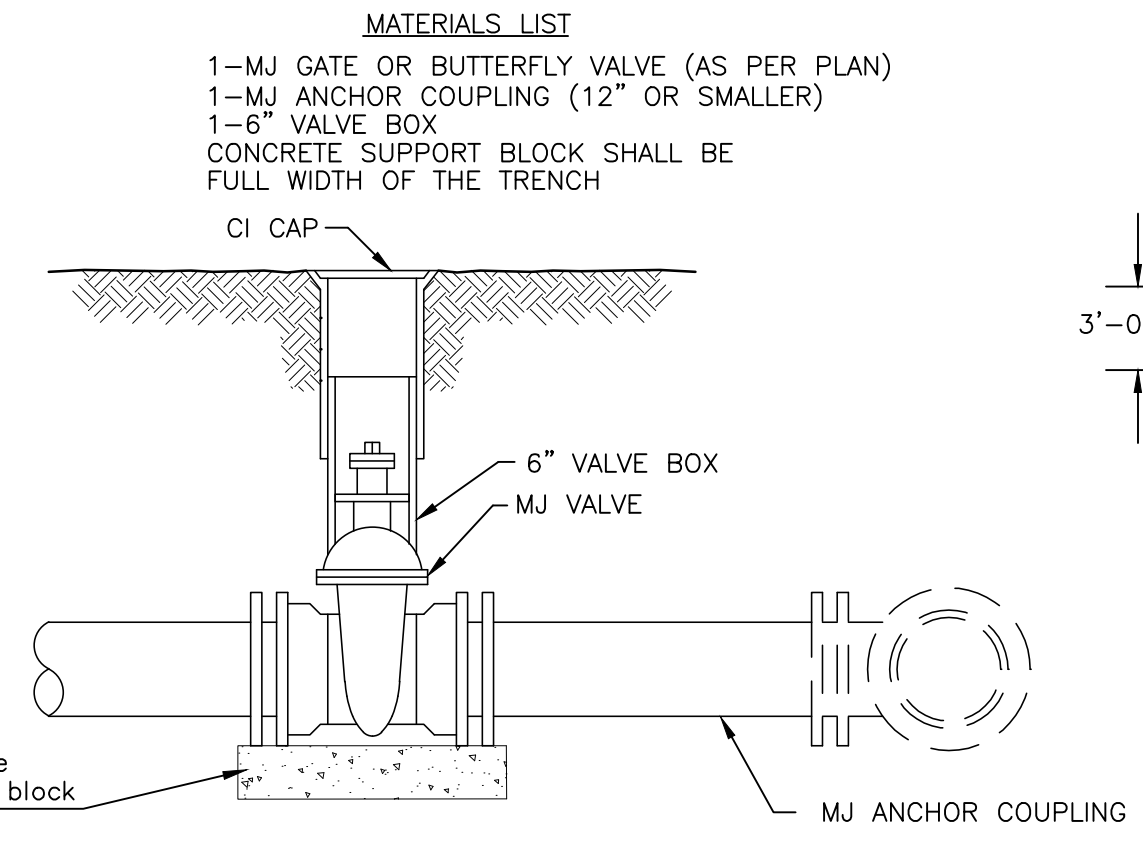

- MATERIALS LIST**
- 1- MJ GATE OR BUTTERFLY VALVE (AS PER PLAN)
 - 1- MJ ANCHOR COUPLING (12" OR SMALLER)
 - 1- 6" VALVE BOX
 - CONCRETE SUPPORT BLOCK SHALL BE FULL WIDTH OF THE TRENCH

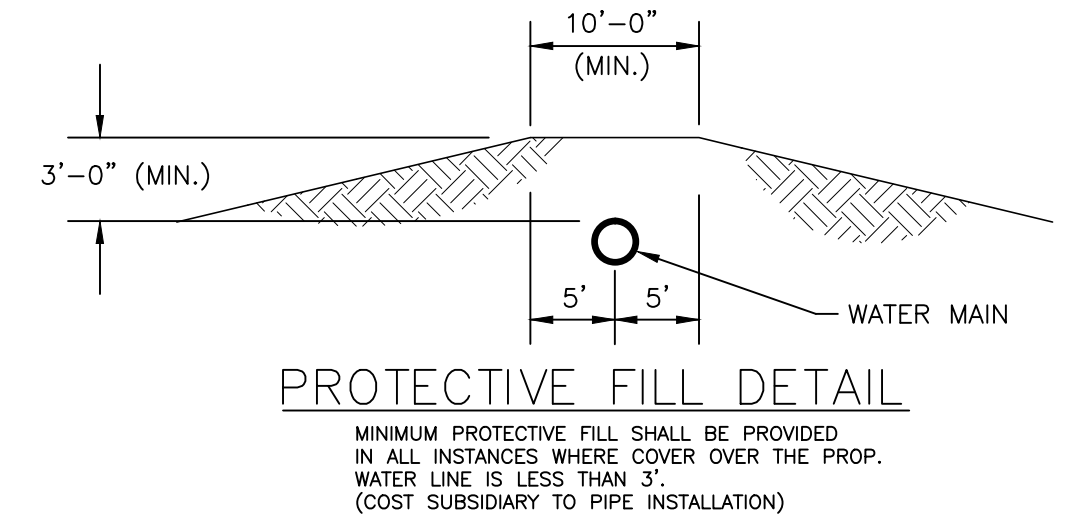

PROTECTIVE FILL DETAIL
MINIMUM PROTECTIVE FILL SHALL BE PROVIDED IN ALL INSTANCES WHERE COVER OVER THE PROP. WATER LINE IS LESS THAN 3'. (COST SUBSIDIARY TO PIPE INSTALLATION)

ANCHORED VALVE ASSEMBLY, SPECIAL

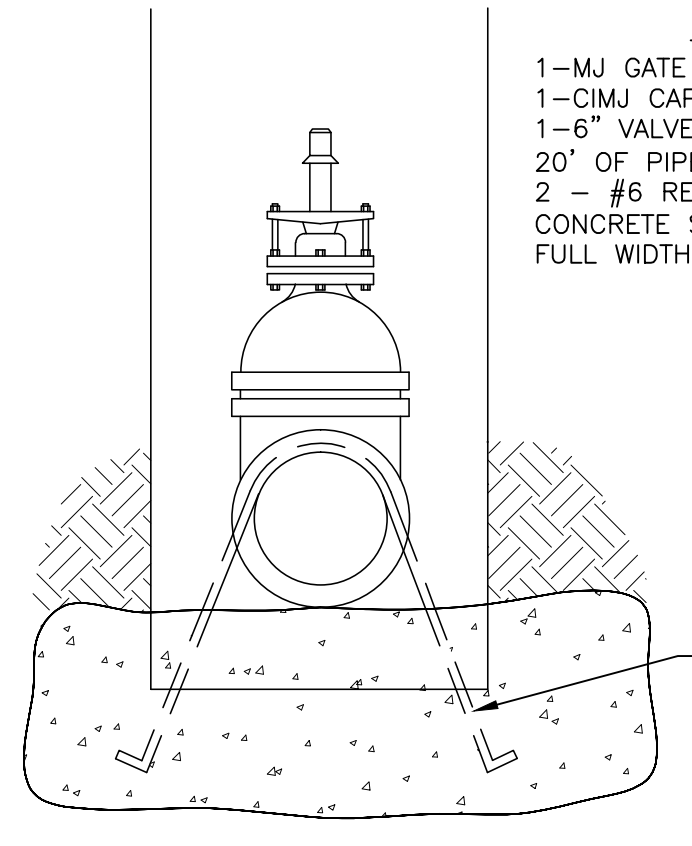

- MATERIALS LIST**
- 1- MJ GATE OR BUTTERFLY VALVE (AS PER PLAN)
 - 1- CIMJ CAP WHEN NECESSARY
 - 1- 6" VALVE BOX
 - 20' OF PIPE (BID WITH PIPE)
 - 2 - #6 REINF. BARS
 - CONCRETE SUPPORT BLOCK SHALL BE FULL WIDTH OF THE TRENCH

Notes:
1. Concrete Block at Valve to have sufficient bearing in undisturbed soil to prevent thrust movement as shown in table at right. Field Engineer to determine thrust loading of undisturbed soil and final size of thrust block.
2. The thrust block shall be constructed such that bolts, nuts, and other MJ accessories are kept clear of concrete.
3. All valves at dead ends and at other locations as called out on the plans shall be blocked as shown here.

THRUST AT VALVES

VALVE	THRUST AT 150 #/sq ft
4"	1809 lbs.
6"	4245 lbs.
8"	7540 lbs.
12"	16965 lbs.

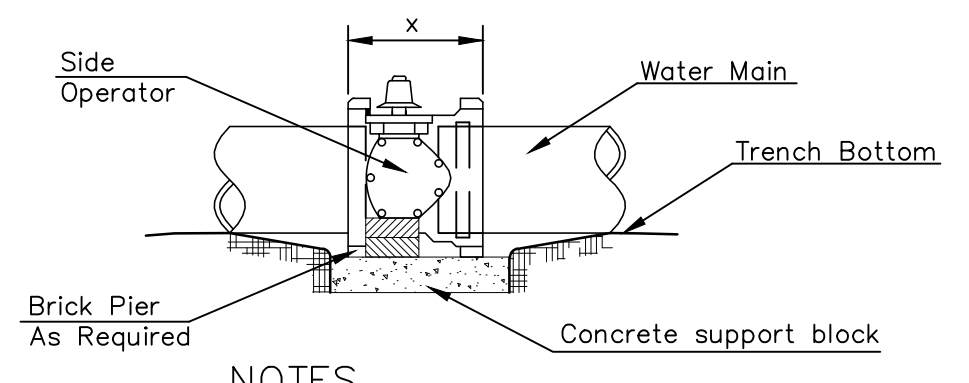

NOTES

- This detail covers Butterfly Valve installation, inclusive, regardless of type of pipe or joint used. 24" and larger lines to be detailed on plans.
- 6" Valve Box and Cover required per City of Wichita Std. Specifications.
- Conc. Support Block to be full width of trench.

CONCRETE SUPPORT BLOCKING FOR BUTTERFLY VALVE INSTALLATION

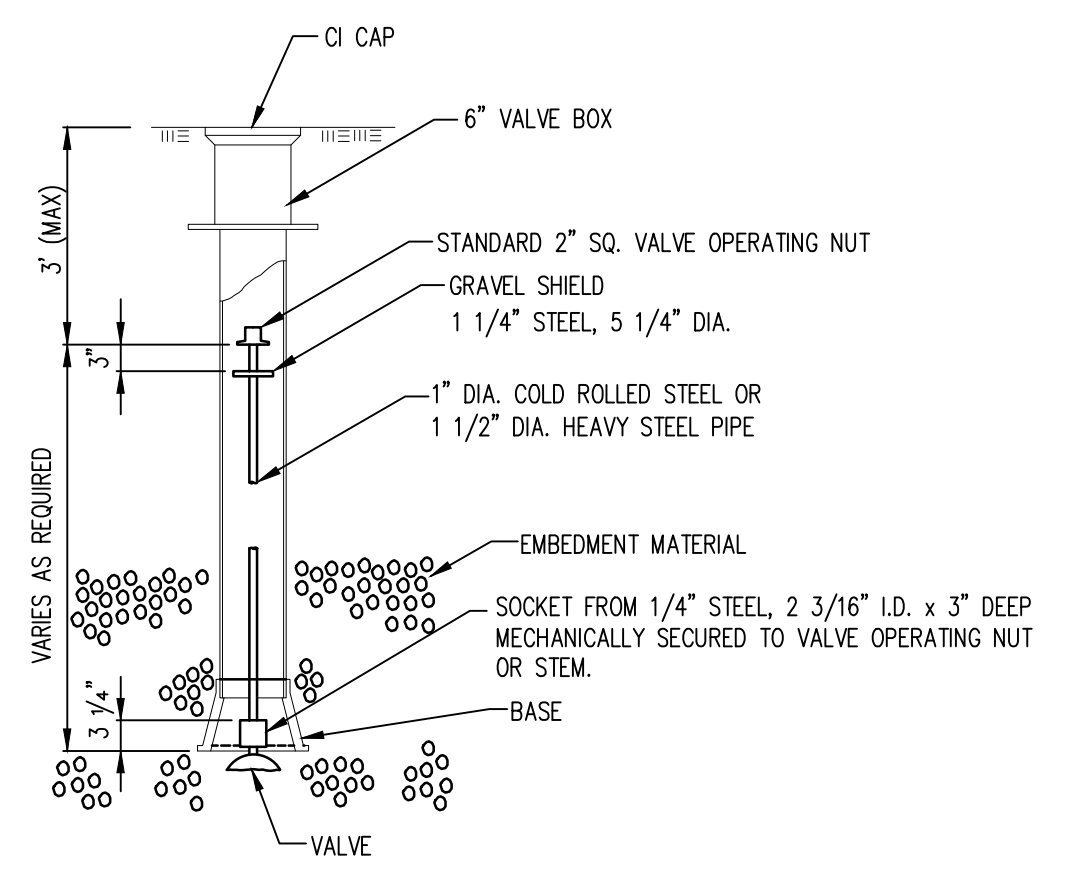

VALVE STEM EXTENSION DETAIL
NOTE: ONE VALVE STEM EXTENSION FOR EACH VALVE BURIED GREATER THAN 5'.

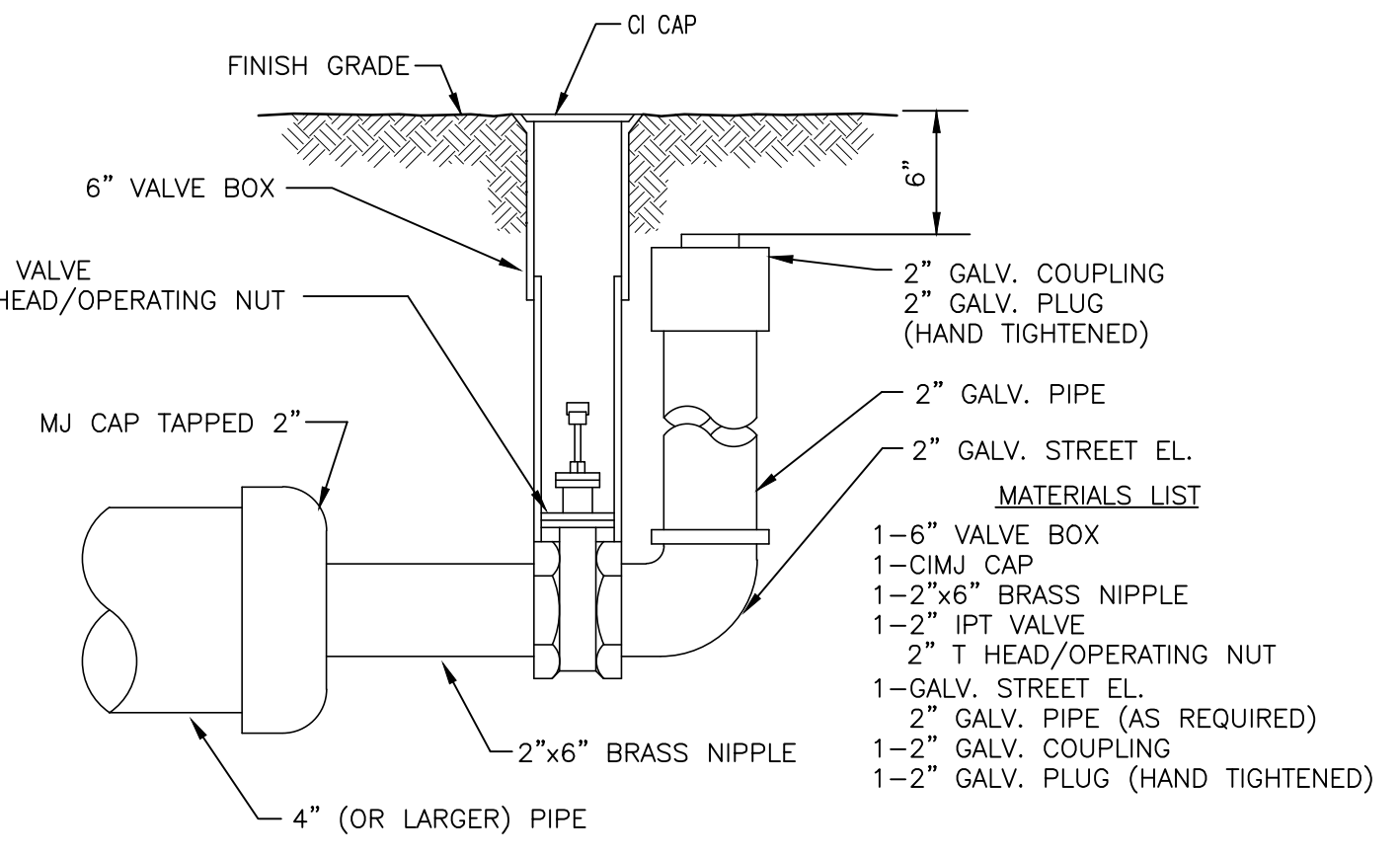

2" BLOWOFF ASSEMBLY



STANDARD WATER ASSEMBLY DETAIL
INTERIM CITY ENGINEER
GARY JANZEN, P.E.

PROJECT NUMBER: OCA NUMBER: DATE: 12/2011

CITY ENGINEER'S OFFICE
CITY HALL - SEVENTH FLOOR
455 NORTH MAIN STREET
WICHITA, KANSAS 67202-1620
(316) 268-4501

KIA ADDITION
KELOGG & TYLER
WATER DISTRIBUTION SYSTEM IMPROVEMENTS
STANDARD WATER DETAILS
CITY OF WICHITA, KANSAS
GARY JANZEN, P.E. - CITY ENGINEER
C.O.M. Proj.# 1708-PPW O.C.A.# 607853

POE & ASSOCIATES, INC.
CONSULTING ENGINEERS
5940 E. Central, Suite 200 • Wichita, KS 67208-4242
Phone 316.685-4111 • FAX 316.685-4444

11/20/12

Engineer: S. SERVIS
Designer: S. SERVIS
Drawing: P:\102020\Bases\W.L.dwg
Date: 2/12/2013

Sheet 3 of 11

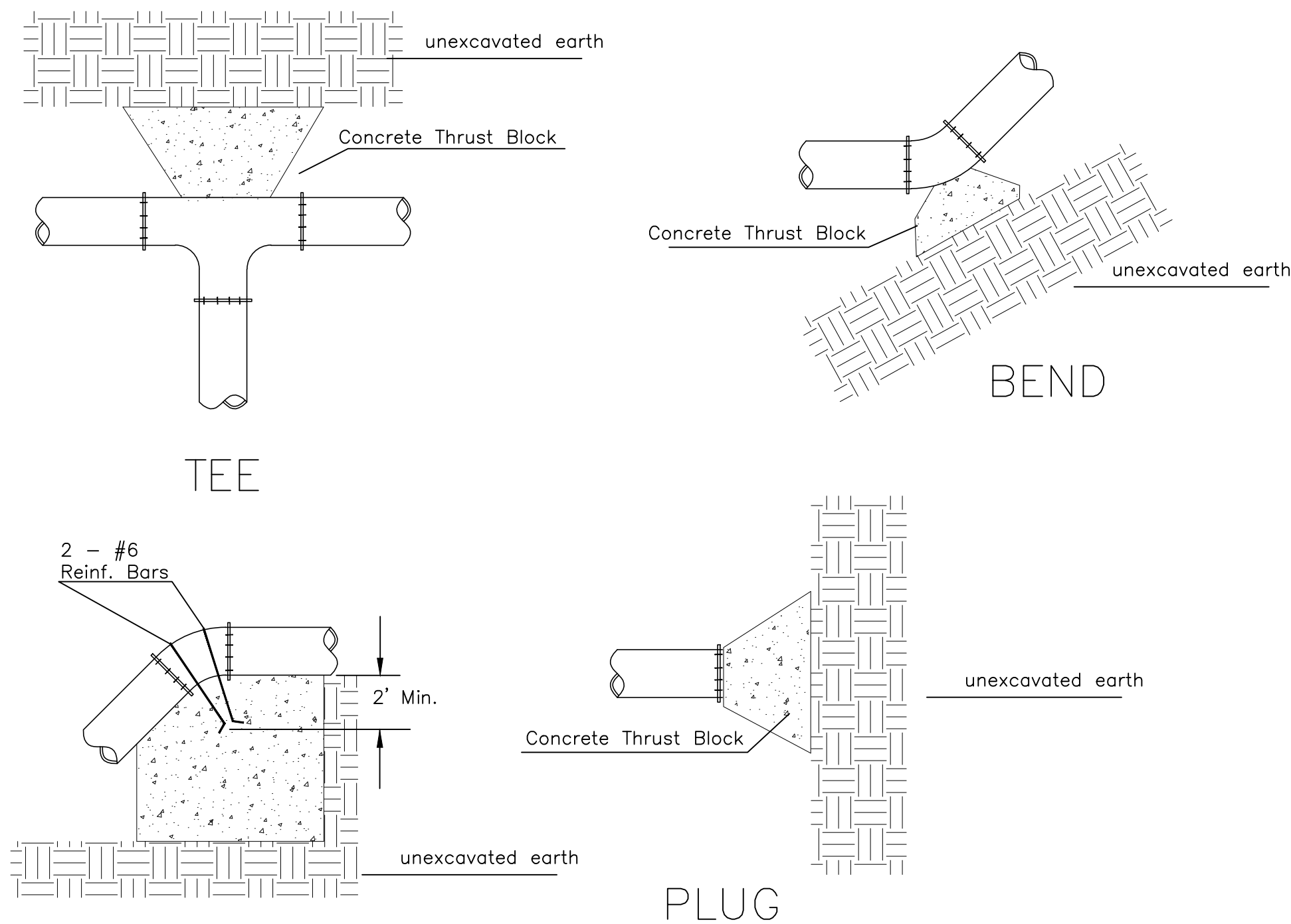

VERTICAL BEND

PIPE SIZE	THRUST AT FITTINGS IN TONS-AT 150#/IN ² P						
	PLUG	90°	45°	22 1/2°	11 1/4°	TEE	
6"	2.8	3.95	2.15	1.09	.55	2.8	
8"	4.9	6.95	3.75	1.90	.96	4.9	
12"	11.4	16.1	8.75	4.45	2.25	11.4	
16"	20.15	28.5	15.4	7.85	3.95	20.15	
20"	31.15	44.0	23.85	12.15	6.10	31.15	
24"	44.55	63.0	34.1	17.4	8.75	44.55	

TYPICAL THRUST BLOCKS

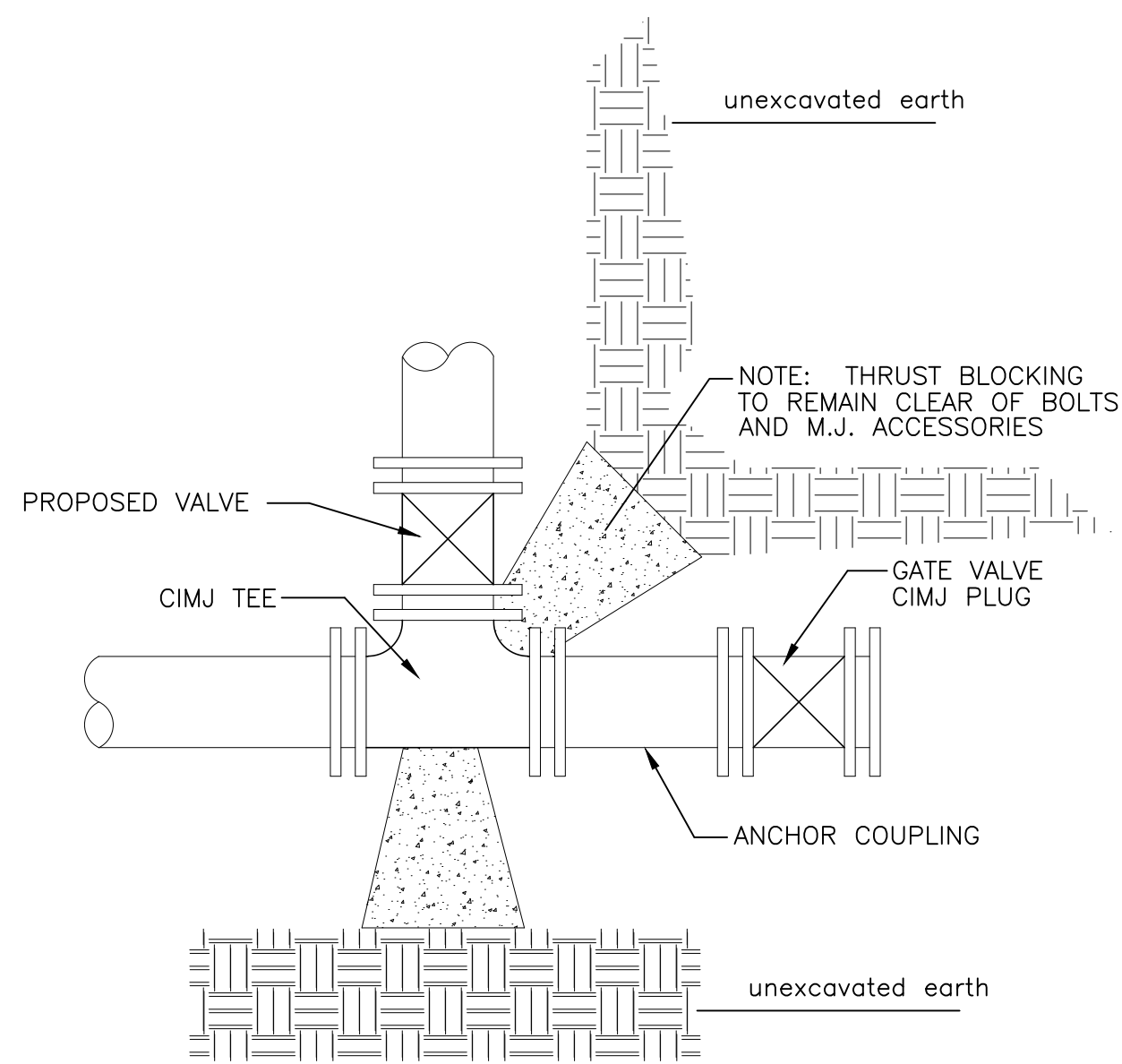

KEY BLOCK DETAIL

TRENCH COMPACTION IN ROAD RIGHT-OF-WAY

PAVEMENT REPLACEMENT & TRENCH COMPACTION UNDER EXISTING AND PROPOSED CITY ROADS
* UNLESS OTHERWISE NOTED ON PLANS

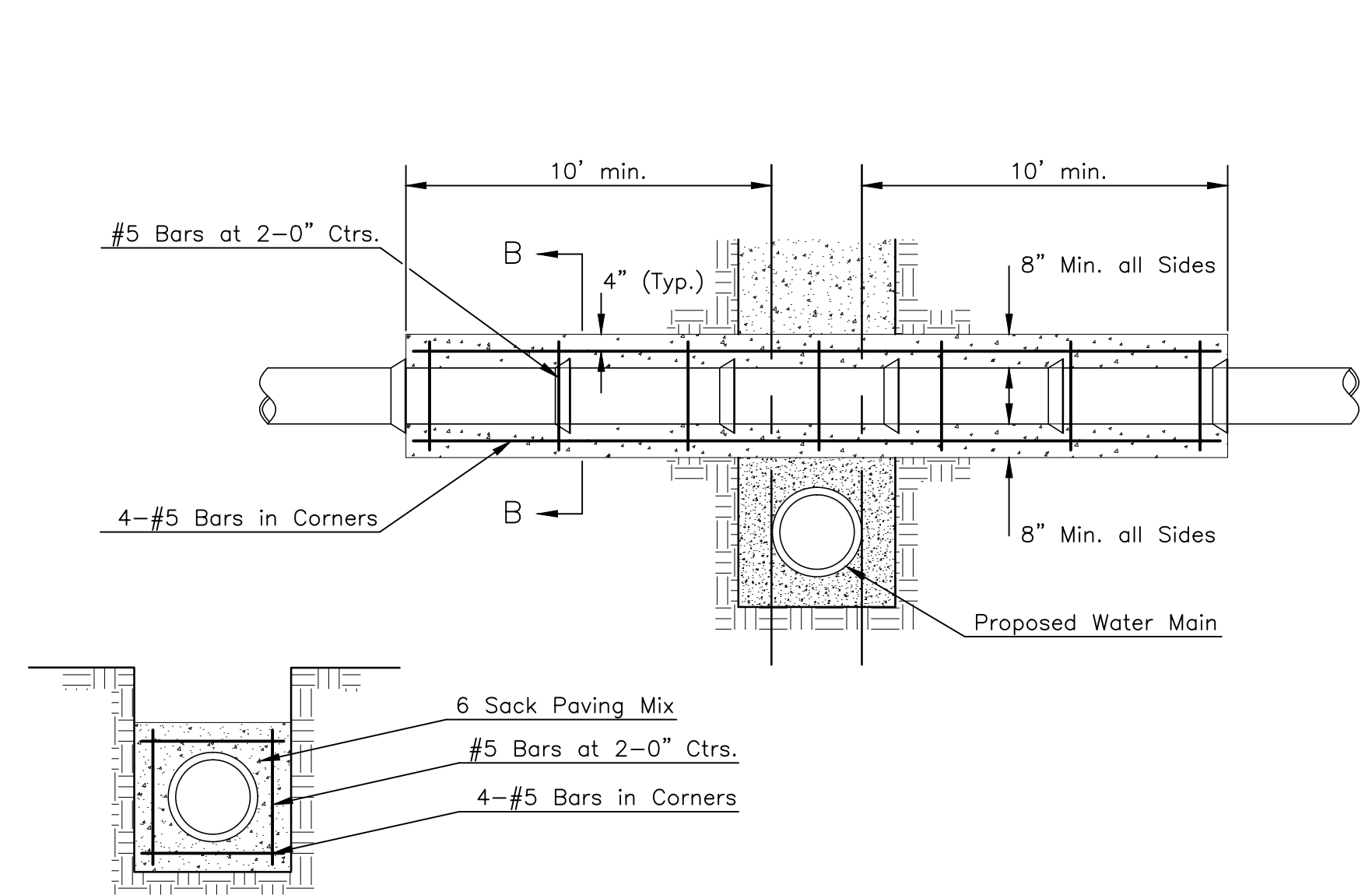
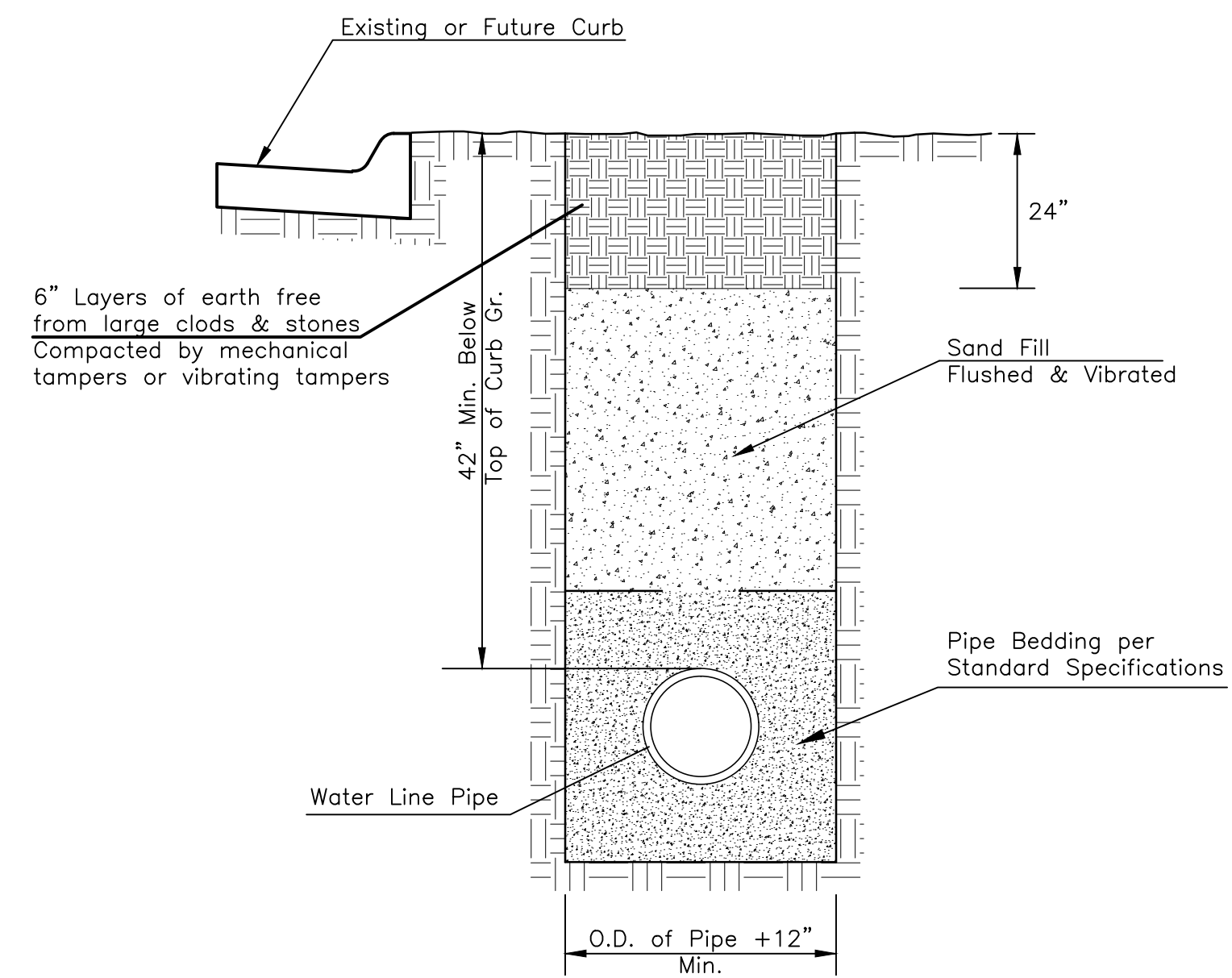

SECTION B-B

REINFORCED CONCRETE ENCASUREMENT OF SANITARY SEWER

Note: Encasement to begin and end at a Bell on Sanitary Sewer Pipe.

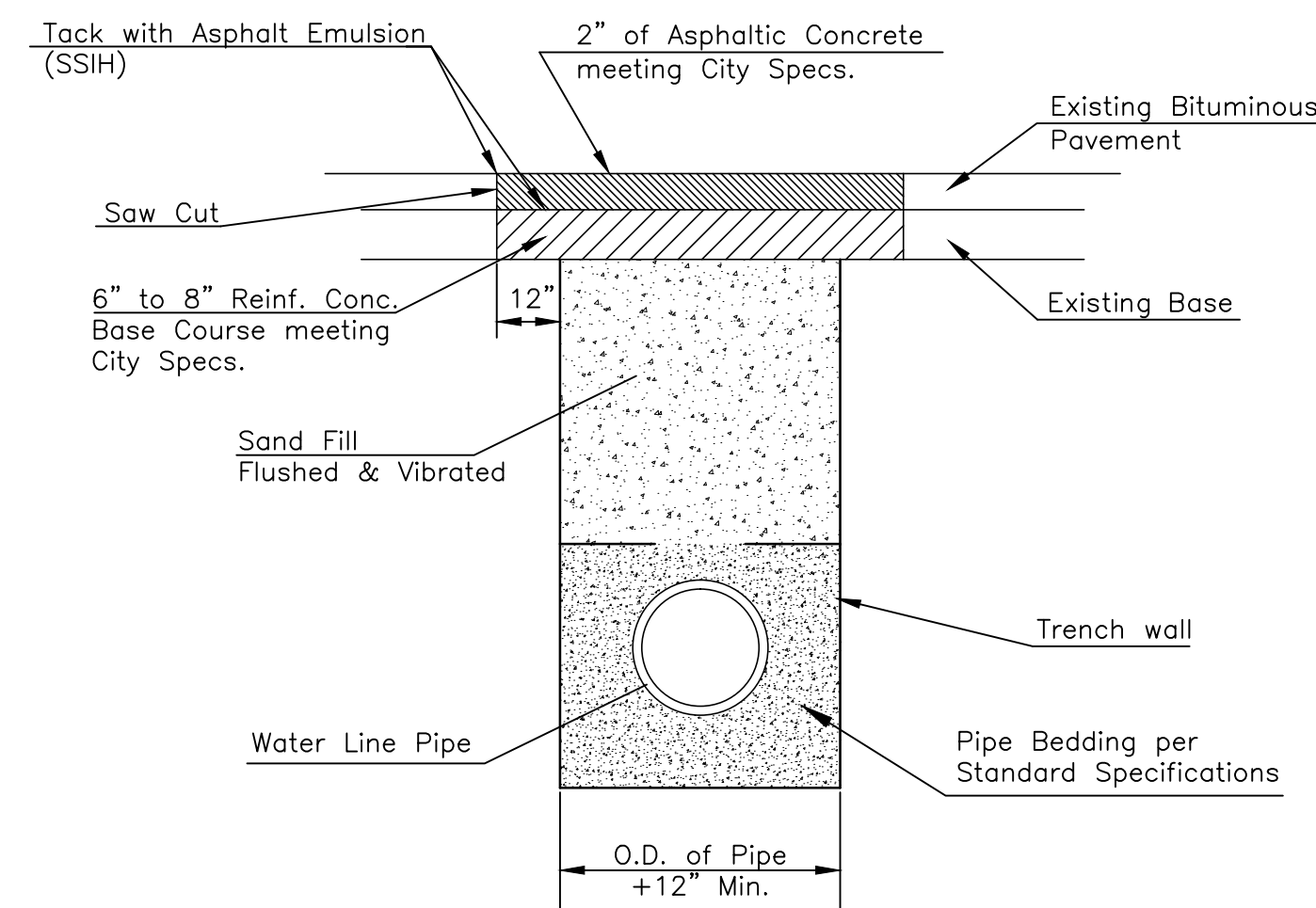

MISCELLANEOUS WATER DETAILS

CITY ENGINEER
JAMES L. ARMOUR, P.E., L.S.

PROJECT NUMBER	OCA NUMBER	DATE
		01/2012

CITY ENGINEER'S OFFICE
CITY HALL - SEVENTH FLOOR
455 NORTH MAIN STREET
WICHITA, KANSAS 67202-1620
(316) 268-4501

SHEET
_ of _

KIA ADDITION
KELLOGG & TYLER
WATER DISTRIBUTION SYSTEM IMPROVEMENTS
MISCELLANEOUS DETAILS
CITY OF WICHITA, KANSAS
GARY JANZEN, P.E. - CITY ENGINEER
C.O.M. Proj.# 1708-PFW O.C.A.# 607853

POE & ASSOCIATES, INC.
CONSULTING ENGINEERS
5940 E. Central, Suite 200 • Wichita, KS 67208-4242
Phone 316.685-1114 • FAX 316.685-4444

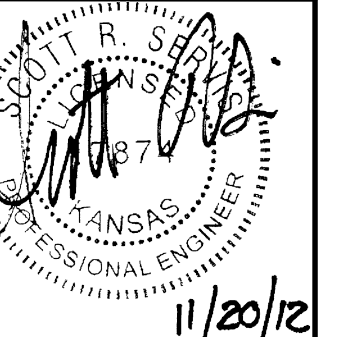
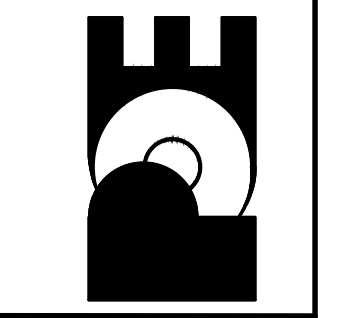

11/20/12

Engineer: S. SERVIS
Designer: S. SERVIS
Drawing: P:\102020\Bases\W.L.dwg
Date: 12/14/2012

Sheet
5 of 11

Notes For All Services - 3" thru 12":

- When the standard vault dimensions are not applicable, such as when additional space is required for special pipe, fittings, additional meters, etc. the design engineer shall design a vault with the required dimensions for Public Works and Utilities approval.
- The vault shall be poured concrete, cement blocks (voids to be completely filled with 2500 P.S.I. concrete), or approved precast structure (such as Clutter Inc. vaults approved 8/1/2000). The intent of these details shall not be limited by drawings or standards of precast structures.
- Vault location to be determined by Public Works and Utilities prior to construction and approved by Department's field supervisor prior to installation. A final inspection will be required for acceptance. Vault location standards include but not limited to: not to be located where subjected to vehicular loads, not to be located in any right-of-way or utility easement, and must be located on the property being served.
- The manhole ring and lid shall be Neenah R-6034 Frame with Type "C" Solid Lid and Drop Down Handle or US Foundry APS-30x30 (Aluminum). Where applicable the standard 10" Public Works and Utilities pattern meter reading lid and ring shall be located directly above water meter register. All meter registers shall have an approved lid directly vertical above. All joints of concrete to concrete or metal to concrete in the construction of the vault shall have an approved water tight mastic joint seal.
- Any fittings or appurtenances required to achieve proper elevation of pipe through the vault shall be provided by the contractor and appropriately noted on as-builts submitted by the inspecting engineer. Such fittings shall be a minimum of 2' from the exterior wall of vault.
- For all domestic services larger than 3" the contractor shall provide an outlet flange connection as shown 8" from the inside wall. Inlet and outlet wall sleeves shall be provided and installed by the contractor and shall be in alignment with one another. The inlet and outlet pipe shall be ductile iron pipe, cement lined, Class 150 per Standard Specifications and shall be continuous through vault wall and joint no less than 2' from the exterior wall of vault. Flanges of inlet and outlet pipes shall be in proper alignment and bolt pattern shall be rotated in such a way that valves and other fittings shall be in their proper vertical alignment when installed.
- For all services 4" and larger the contractor shall install a mega lug, restrained joint, or approved equal on the exterior walls of the vault, which shall be manufactured of ductile iron conforming to ASTM A 536-80, heat treated to a minimum hardness of 370 BHN and have a working pressure of at least 250 P.S.I. For all services smaller than 4" the contractor shall install an approved vault clamp on the exterior walls of the vault.
- All valves, meters, assemblies, and fittings shall be provided with sufficient concrete or other approved supports to the vault floor.
- The "Confined Space Warning" sign shall be fastened to the top of all vaults. If necessary for landscaping or site considerations, the sign may be fastened to the vault lid if it does not impede access to the handle. Acceptable materials: Aluminum 73415HH, Plastic 73439HH, or S.A. Vinyl 73463HH.
- All meters shall have an electronic read register compatible with the current City of Wichita meter reading system. All detector meters shall be an 5/8 cubic foot Badger meter with ERT register or approved equal. Gallon meters shall not be accepted.
- Additional Notes For Fire Services:
 - A post indicator valve (PIV) is an option for the outlet valve and may be requested by the architect or owner. The PIV is not required by City of Wichita ordinance.
 - When Siamese connections are required by the Wichita Fire Department, refer to the current City Code Section 15.
 - If due to any reason the completed vault retains ground or drainage water in excess of 4" in depth from the floor of the vault, the property owner shall be responsible for providing and installing an appropriate automatic sump pump or approved equal, as well as any other appurtenances required to make such system function as intended.
 - The property owner is responsible for completing an "Application for Private Fire Protection" prior to final acceptance of the project.

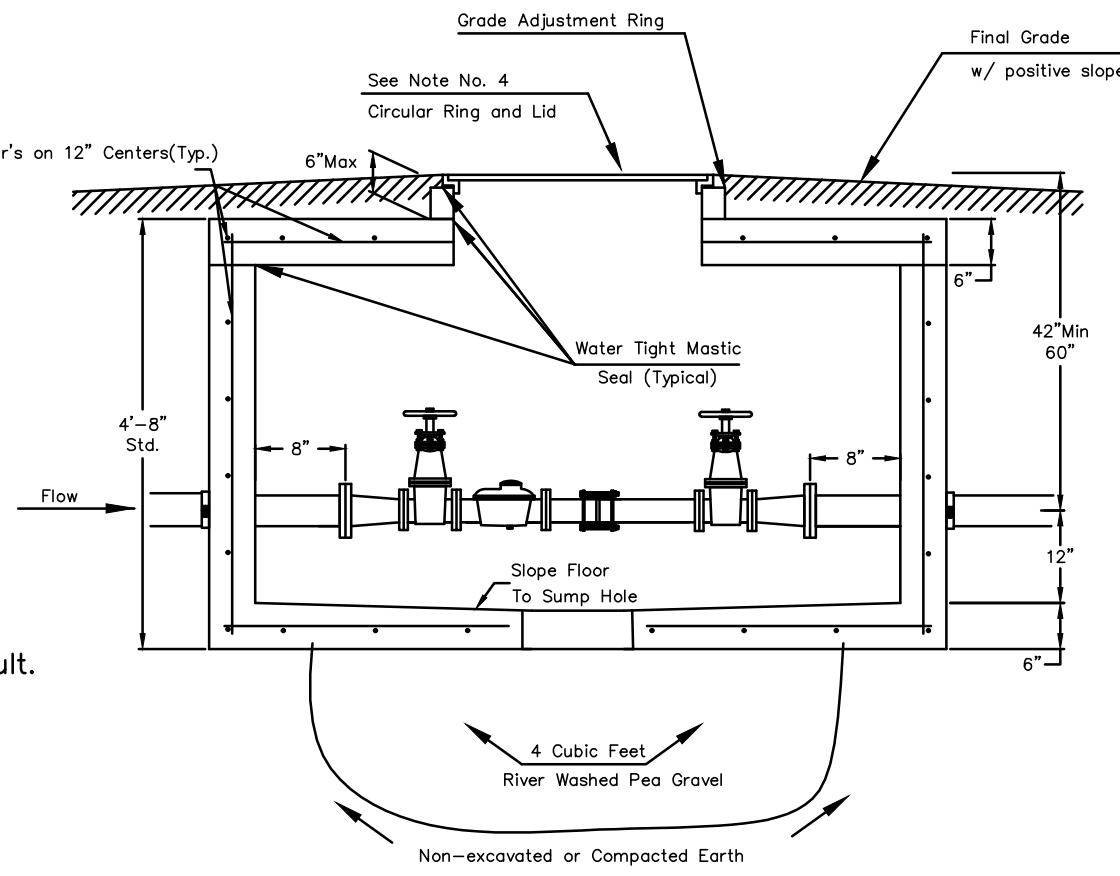
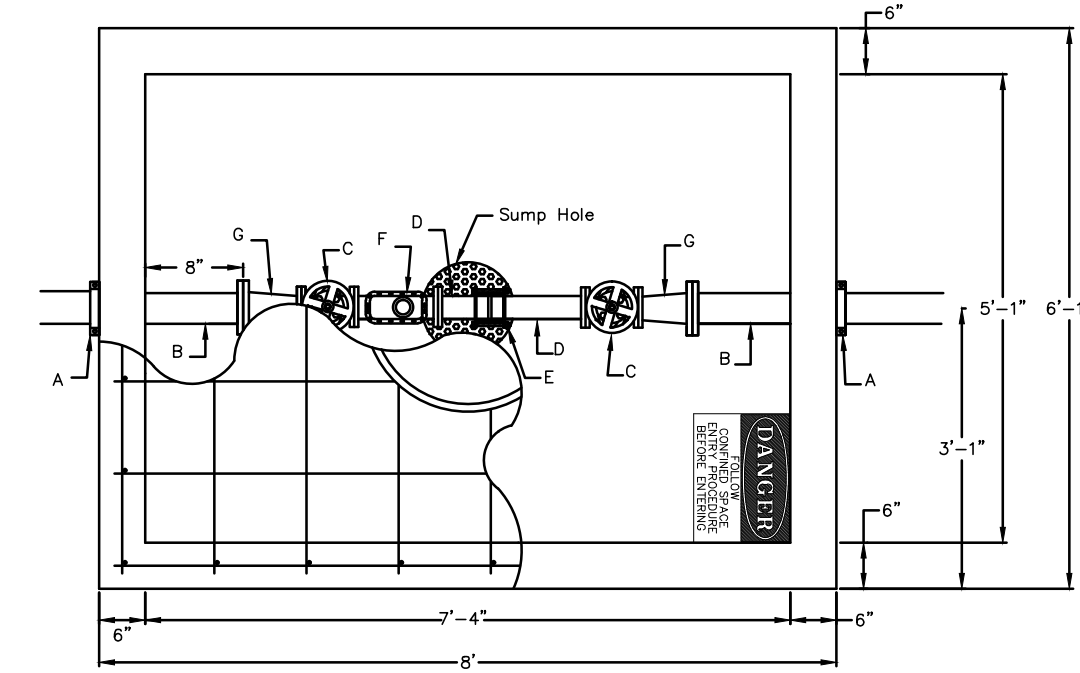

- A - 4" Vault Clamp
- B - Min. 3" Piece of 4" FL x PE DICL Pipe
- C - 3" Flange Non-rising Stem Gate Wheel Valve
- D - 3" FL x PE Pipe
- E - 3" Flex Coupling
- F - 3" Badger Recordall II Turbo Cubic Foot Meter with ERT Register or Sensus W-350DR Cubic Foot Meter with AMR Register.
- G - 3" x 4" FL Reducer

3" Domestic Service

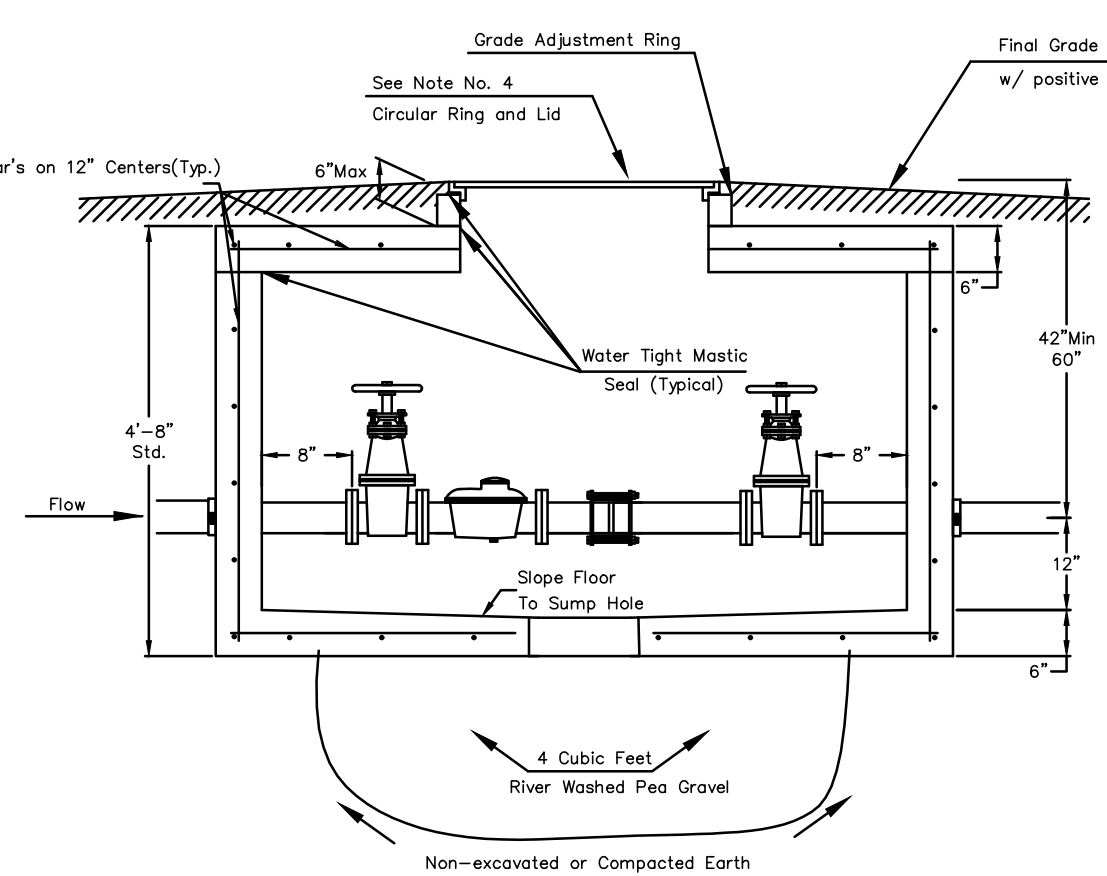
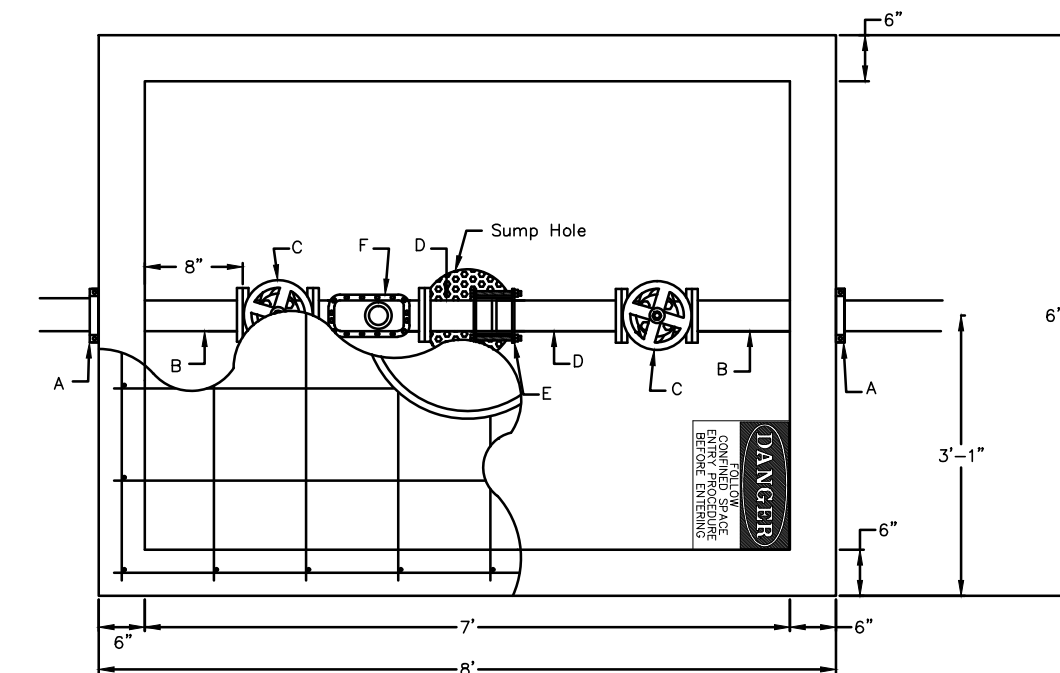

- A - 4" Vault Clamp
- B - Min. 3" Piece of 4" FL x PE DICL Pipe
- C - 4" Flange Non-rising Stem Gate Wheel Valve
- D - 4" FL x PE Pipe
- E - 4" Flex Coupling
- F - 4" Badger Recordall II Turbo Cubic Foot Meter with ERT Register or Sensus W-1000DR Cubic Foot Meter with AMR Register.

4" Domestic Service

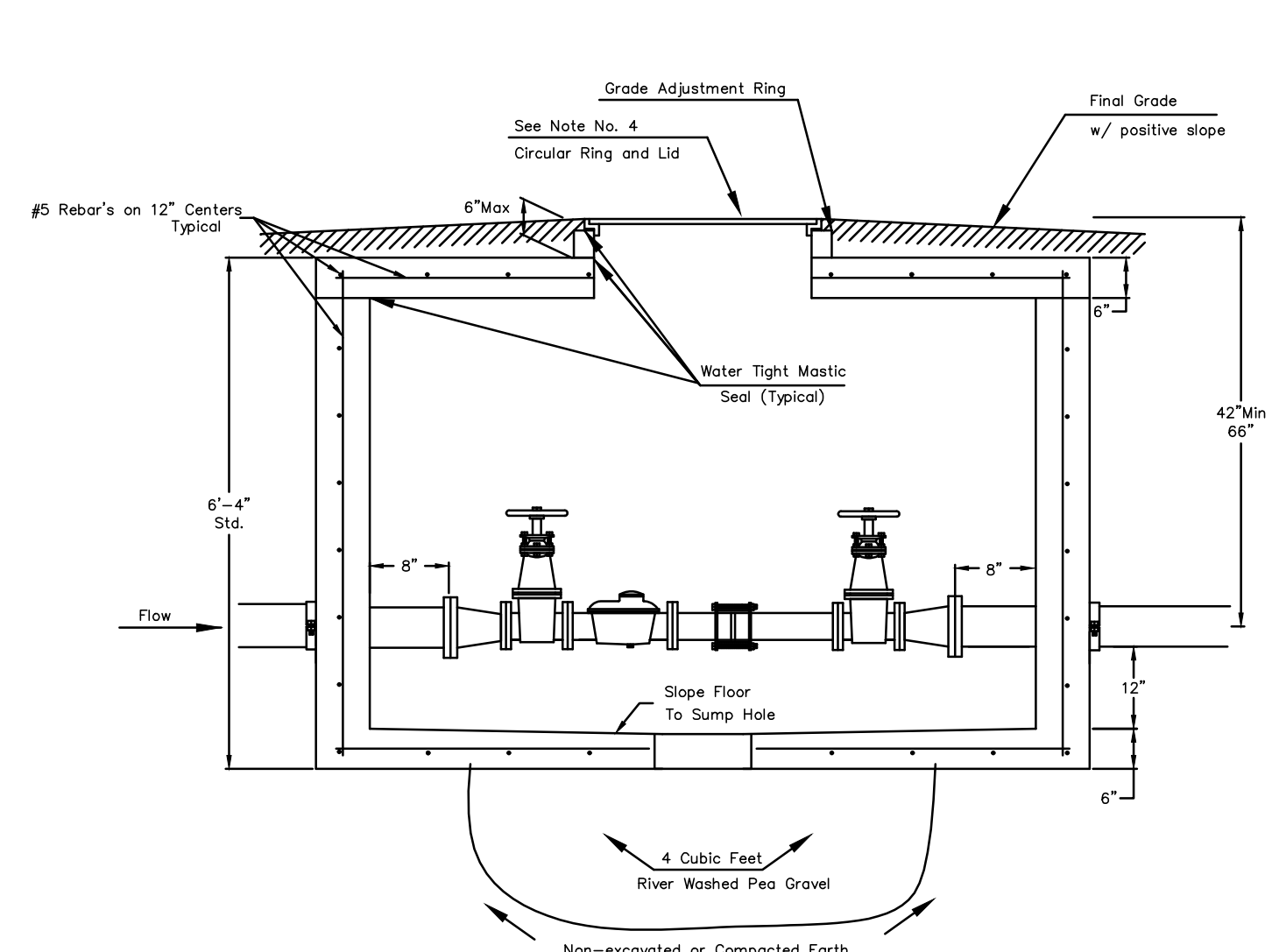
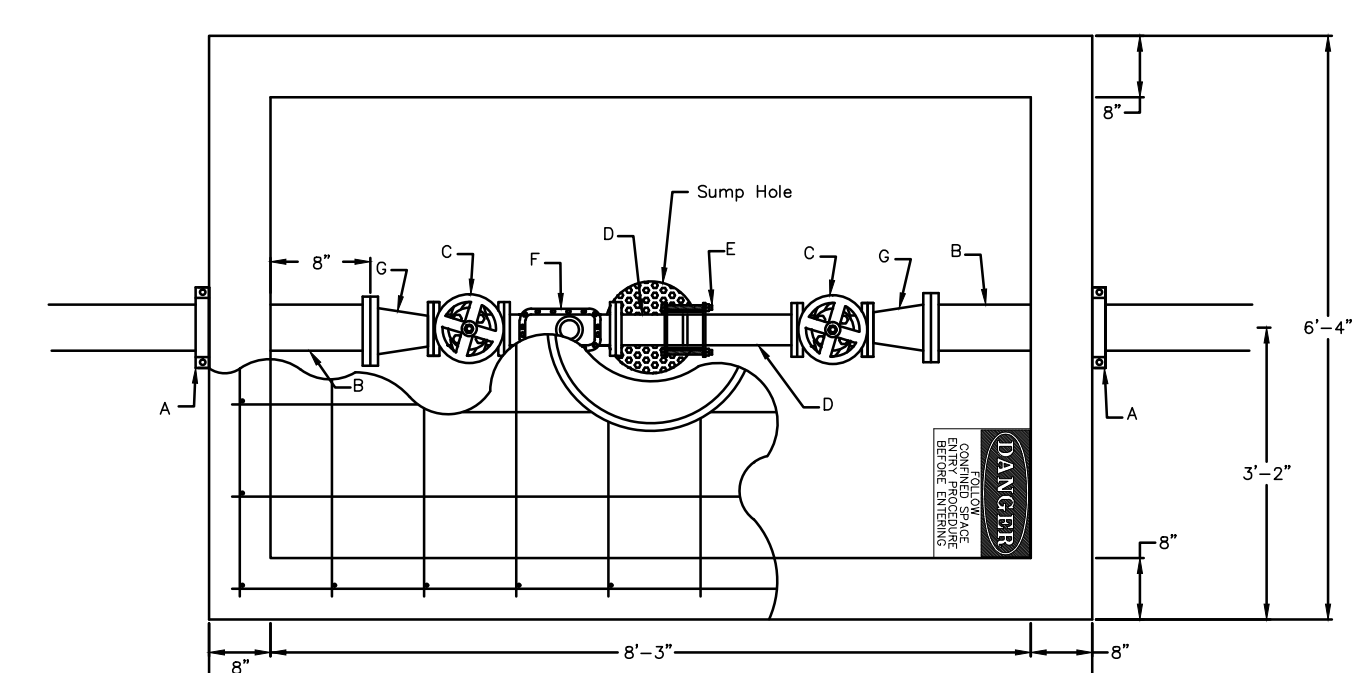

- A - 6" Mega Lug (See Note 7)
- B - Min. 3" Piece of 6" FL x PE DICL Pipe
- C - 4" Flange Non-rising Stem Gate Wheel Valve
- D - 4" FL x PE Pipe
- E - 4" Flex Coupling
- F - 4" Badger Recordall II Turbo Cubic Foot Meter with ERT Register or Sensus W-1000DR Cubic Foot Meter with AMR Register.
- G - 6" x 4" Flange Reducer

6" Domestic Service with 4" meter

NOTE:
INSPECTOR FROM PUBLIC WORKS AND UTILITIES TO BE CONTACTED 24 HOURS PRIOR TO INSTALLATION TO SET VAULT.
CONTACT: 316-219-8928 OR 316-219-8929

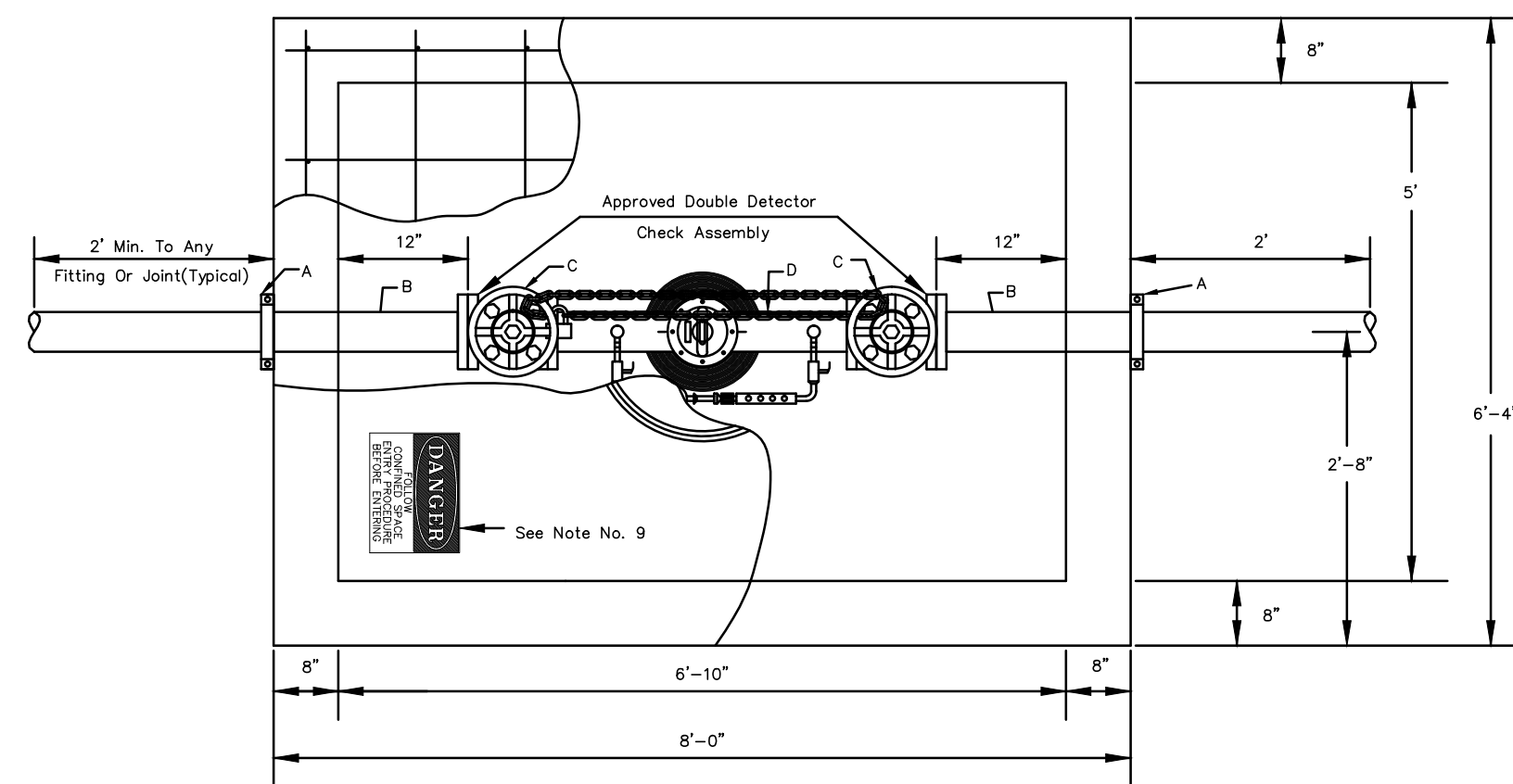

- A - Mega Lug (See Note 7)
- B - Min. 3"-8" Piece of FL x PE DICL Pipe
- C - Flange Gate Valve, Wheel Operated
- D - Ames Model 3001SS or approved equal with metered(cubic foot) by-pass assembly

4" thru 8" Fire Service

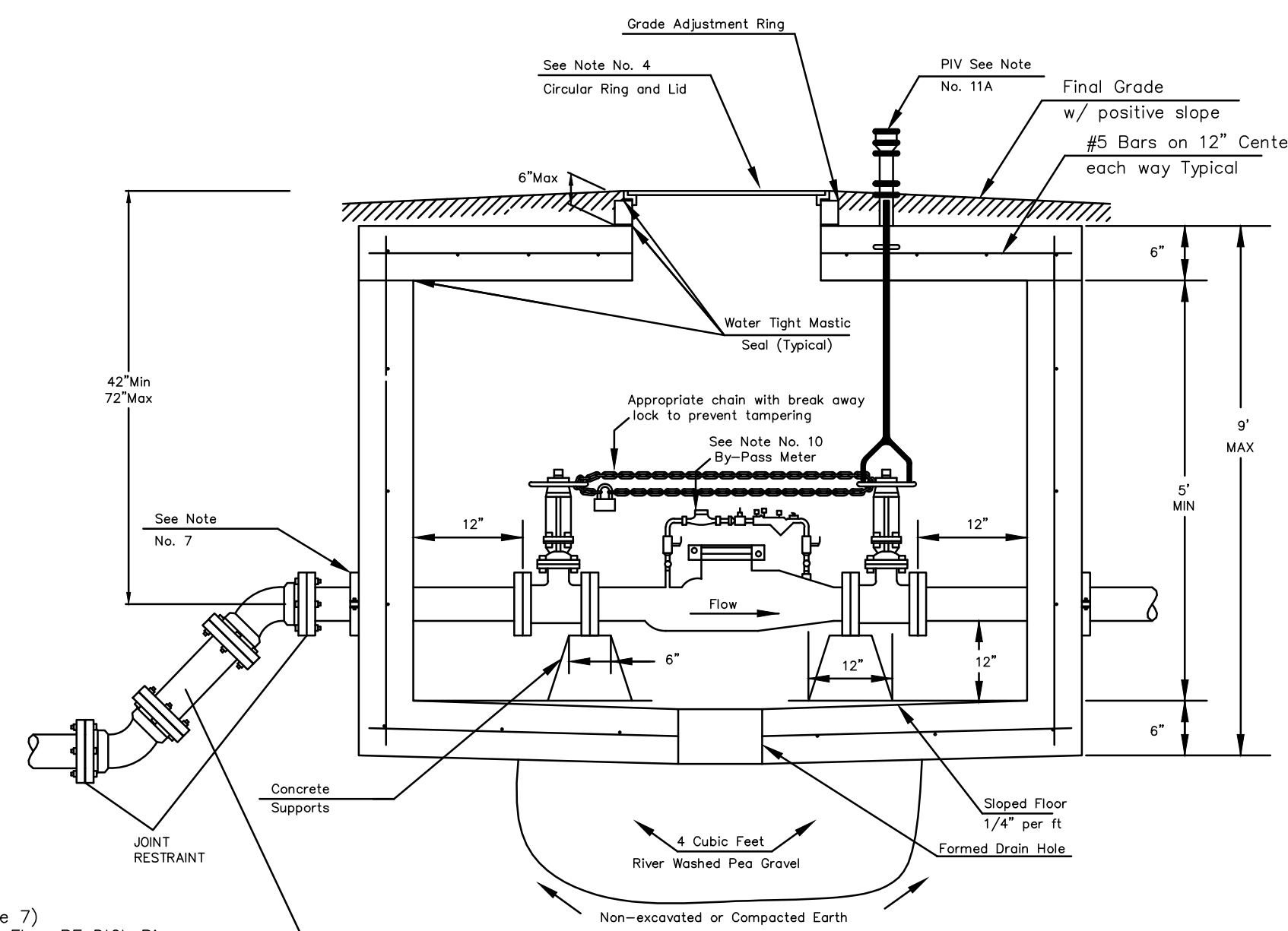

NOTE:
Domestic Services larger than 6" shall be custom designed by Engineer.



STANDARD VAULT DETAILS AND METER ASSEMBLIES		
CITY ENGINEER		
JAMES L. ARMOUR, P.E., L.S.		
PROJECT NUMBER	OCA NUMBER	DATE
		12/2011
CITY ENGINEER'S OFFICE		SHEET
CITY HALL - SEVENTH FLOOR		
455 NORTH MAIN STREET		
WICHITA, KANSAS 67202-1620		
(316) 268-4501		
		of

Approved/Revision
 Date
 No.
 KIA ADDITION
 KELLOGG & TYLER
 WATER DISTRIBUTION SYSTEM IMPROVEMENTS
 MISCELLANEOUS DETAILS
 CITY OF WICHITA, KANSAS
 GARY JANZEN, P.E. - CITY ENGINEER
 C.D.M. Proj.# 1708-PFW O.C.A.# 607853
 POE & ASSOCIATES, INC.
 CONSULTING ENGINEERS
 5940 E. Central, Suite 200 • Wichita, KS 67208-4242
 Phone 316/685-4111 • FAX 316/685-4444

 5A of 11

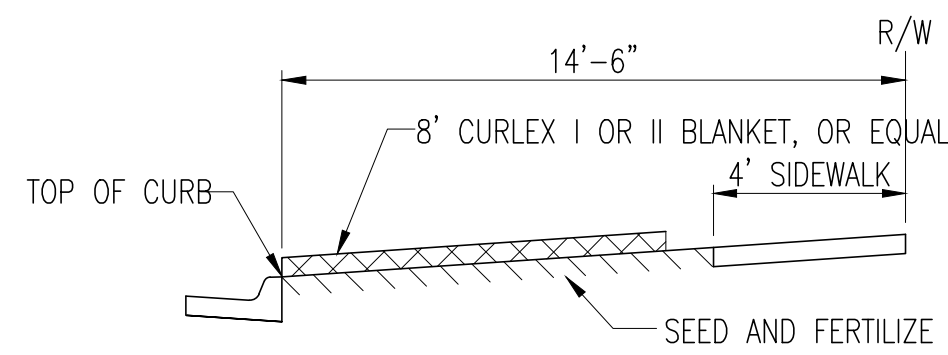

SECTION B-B

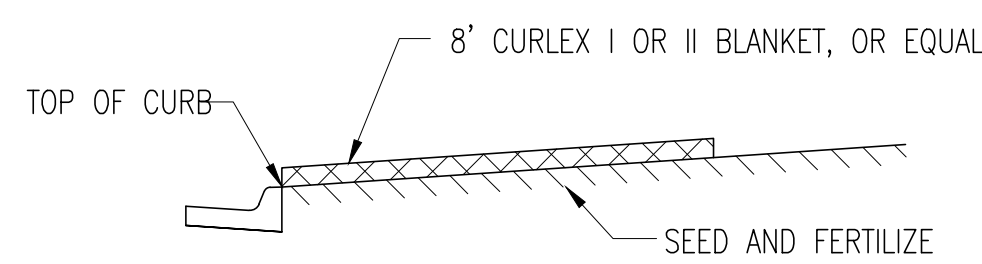

SECTION A-A

INSTALL 8' WIDE CURLEX I OR II EXCELSIOR BLANKET, OR EQUAL, ON PREPARED SURFACE BACK OF CURB. EDGE OF BLANKET WILL BE AT BACK OF CURB. INSTALL PER MANUFACTURER'S RECOMMENDATION, INCLUDING STAPLES. (SEE DETAIL)

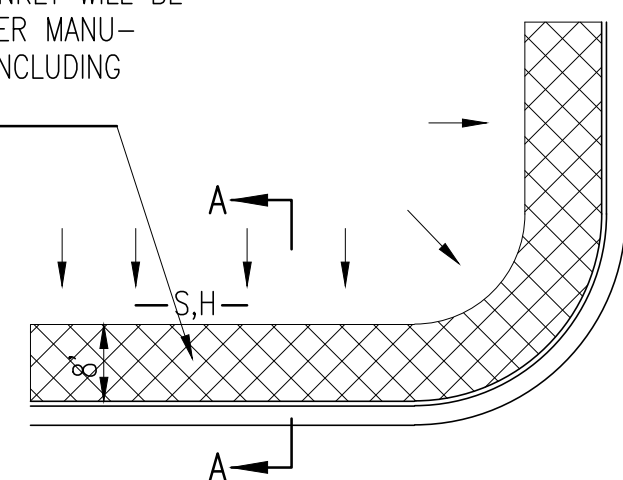

SOUTH STREET

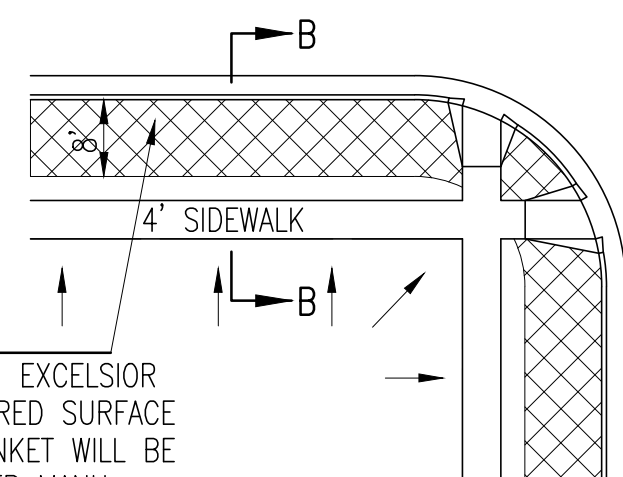

INSTALL 8' WIDE CURLEX I OR II EXCELSIOR BLANKET, OR EQUAL, ON PREPARED SURFACE BACK OF CURB. EDGE OF BLANKET WILL BE AT BACK OF CURB. INSTALL PER MANUFACTURER'S RECOMMENDATION, INCLUDING STAPLES. (SEE DETAIL)

GENERAL NOTES

- EXCELSIOR MAT TO BE INSTALLED WHEN SOD IS NOT SPECIFIED ON PROJECT.
- EXCELSIOR BLANKET TO BE INSTALLED OVER SEED AND FERTILIZER, AS SPECIFIED IN THE PROJECT SPECIFICATIONS.
- AFTER INSTALLATION OF EXCELSIOR BLANKET, AT LOCATIONS WHERE CONCENTRATED FLOW CARRIES SEDIMENT OVER THE CURB AND INTO THE GUTTER, SUPPLEMENTAL EROSION CONTROL DEVICES WILL BE INSTALLED BY THE CONTRACTOR AS NEEDED, TO FIX THE PROBLEM.

BACK OF CURB PROTECTION DETAIL

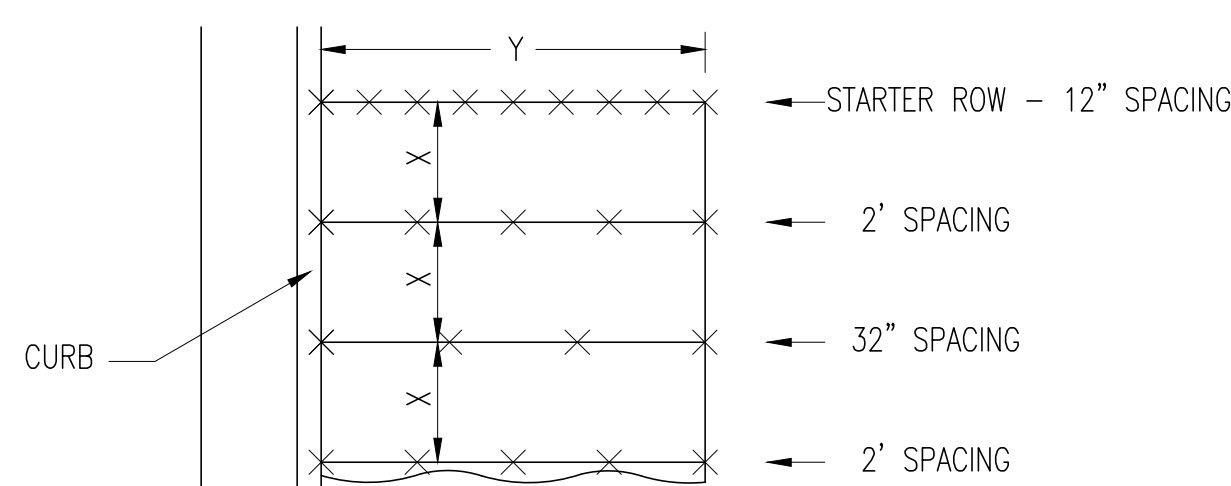

STAPLE PATTERN

NOTES: USE 6" SEAM OVERLAP
(X & Y = RECOMMENDED BY MANUFACTURE)

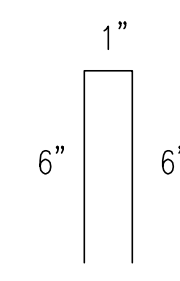

11 GA. WIRE STAPLE

DETAILS FOR APPROVED EROSION CONTROL MAT

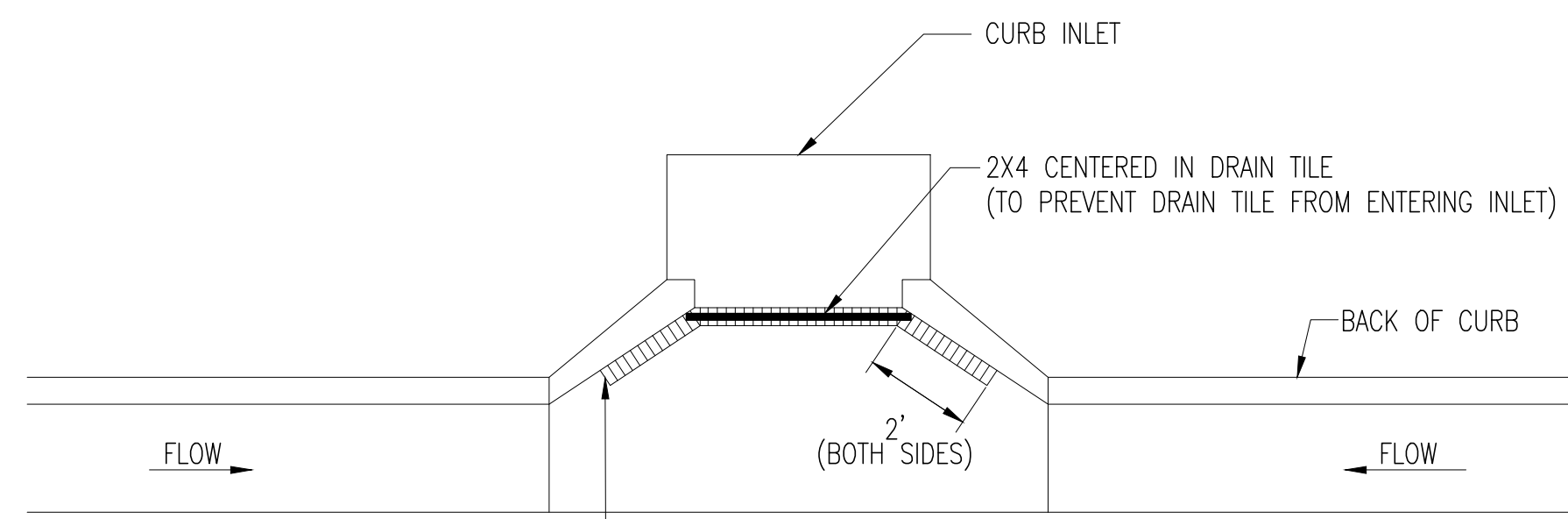

NOTE: PLACE 4" PERFORATED PVC PIPE, FILLED WITH 1/2"-1" DIA. GRAVEL, IN FRONT OF CURB INLET AS SHOWN.

2X4 LENGTH	INLET TYPE	INLET OPENING
5'-6"	1-A	5'-0"
10'-6"	1-A	10'-0"
15'-6"	1-A	15'-0"

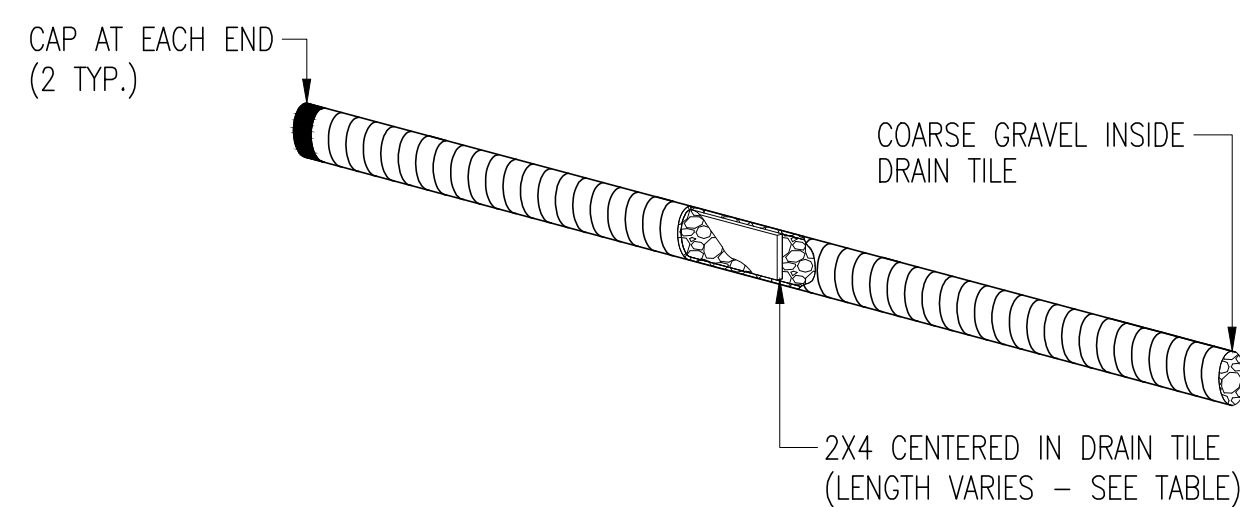

CURB INLET PROTECTION
4" PERFORATED PIPE W/ GRAVEL

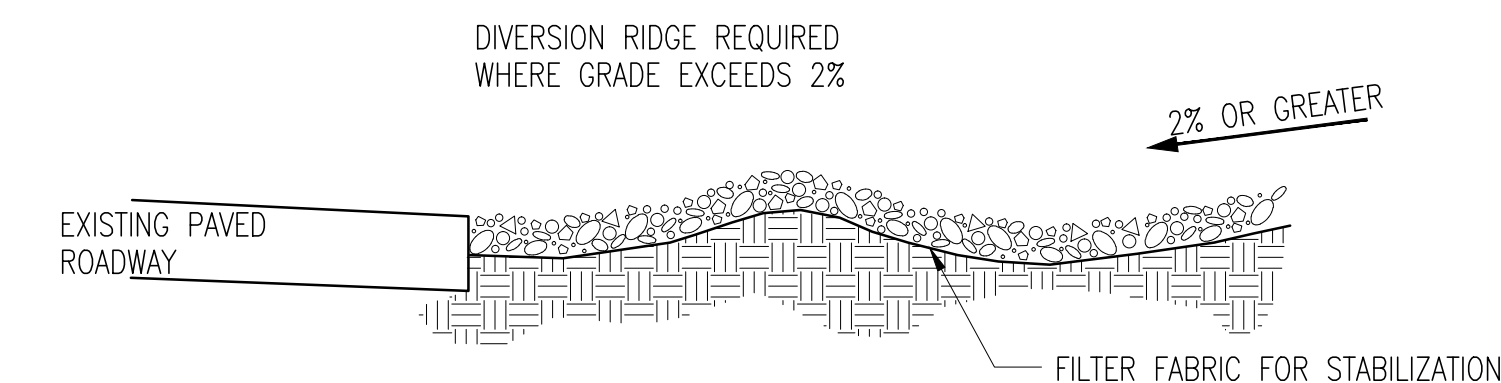

SECTION C-C

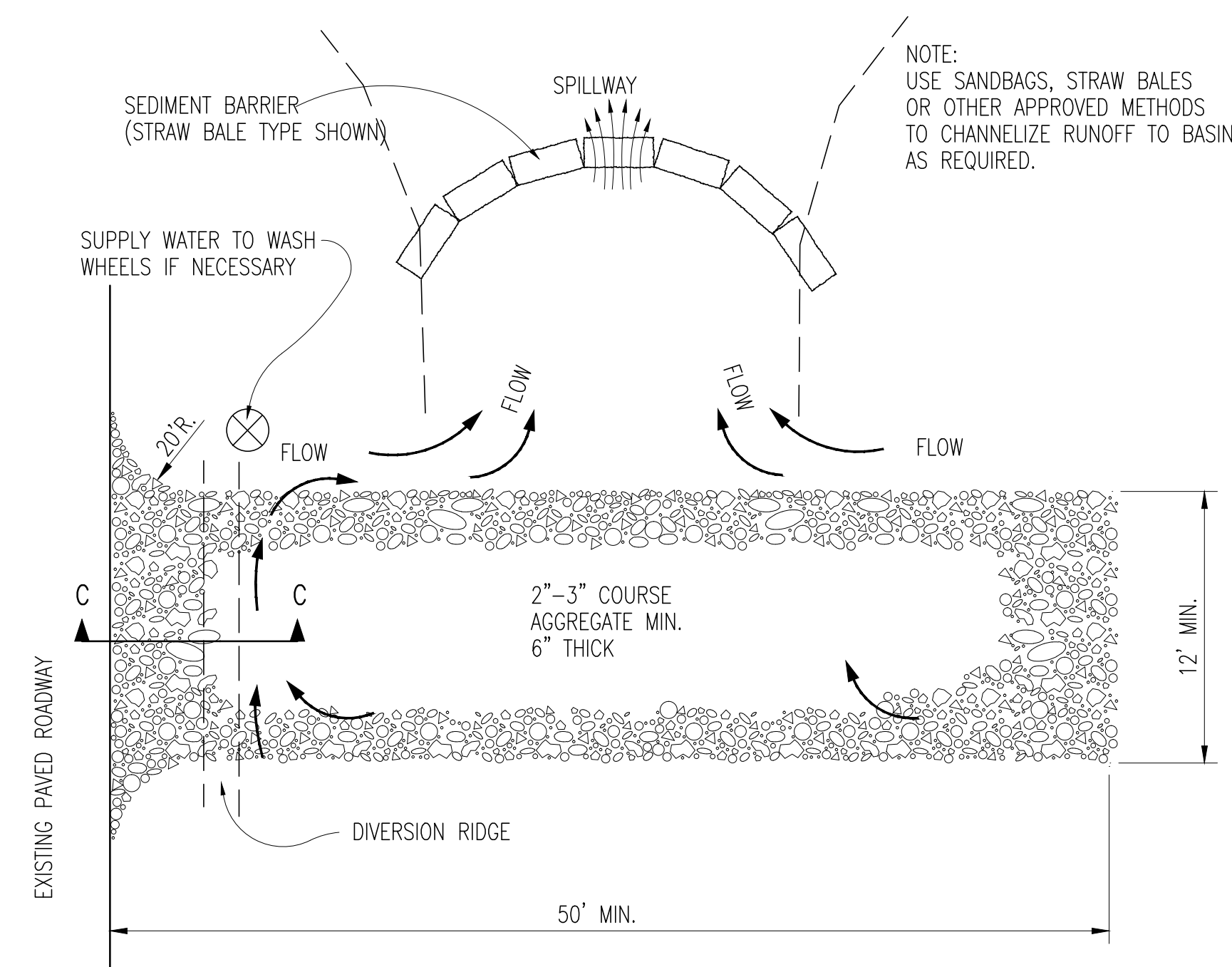

STABILIZED CONSTRUCTION ENTRANCE

GENERAL NOTES

- THE ENTRANCE SHALL BE MAINTAINED IN A CONDITION THAT WILL PREVENT TRACKING OR FLOWING OF SEDIMENT ONTO PUBLIC RIGHTS-OF-WAY. THIS MAY REQUIRE TOP DRESSING, REPAIR AND/OR CLEANOUT OF ANY MEASURES USED TO TRAP SEDIMENT.
- WHEN NECESSARY, WHEELS SHALL BE CLEANED PRIOR TO ENTRANCE ONTO PUBLIC RIGHT-OF-WAY.
- WHEN WASHING IS REQUIRED, IT SHALL BE DONE ON AN AREA STABILIZED WITH CRUSHED STONE THAT DRAINS INTO AN APPROVED SEDIMENT TRAP OR SEDIMENT BASIN, AS SHOWN ABOVE.
- DRIVE ENTRANCES ONTO RESIDENTIAL LOTS WILL NOT BE REQUIRED TO HAVE THE SEDIMENT BARRIER SHOWN, BUT WHEEL WASHING MAY BE REQUIRED IF STABILIZED ENTRANCE IS NOT SUFFICIENT TO KEEP MUD FROM BEING TRACKED ONTO ADJACENT STREET. ENTRANCE SHALL EXTEND FROM BACK OF CURB TO DWELLING.



BACK OF CURB PROTECTION, CURB INLET PROTECTION AND CONSTRUCTION ENTRANCE

INTERIM CITY ENGINEER

GARY JANZEN, P.E.

PROJECT NUMBER: OCA NUMBER: DATE: 08/2012

CITY ENGINEER'S OFFICE
CITY HALL - SEVENTH FLOOR
455 NORTH MAIN STREET
WICHITA, KANSAS 67202-1620
(316) 268-4501

DESIGN: DRAWN: SHEET: 3 of 6

No.	Date	By	Approved	Revision

KIA ADDITION
KELLOGG & TYLER
WATER DISTRIBUTION SYSTEM IMPROVEMENTS
EROSION CONTROL DETAILS
CITY OF WICHITA, KANSAS
GARY JANZEN, P.E. - CITY ENGINEER
C.O.M. Proj.# 1708 PFW O.C.A.# 607853

POE & ASSOCIATES, INC.
CONSULTING ENGINEERS
5940 E. Central, Suite 200 • Wichita, KS 67208-4242
Phone 316.685.4114 • FAX 316.685.4444

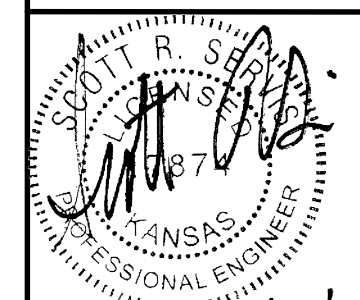
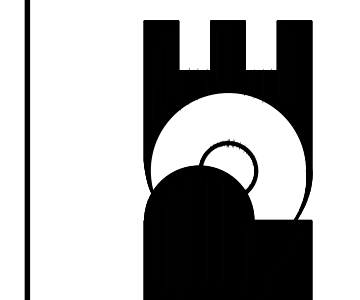

11/20/12

WICHITA
Engineer: S. SERVIS
Designer: S. SERVIS
Drawing: P:\102020\Bases\W.L.dwg
Date: 12/14/2012
Sheet 6 of 11

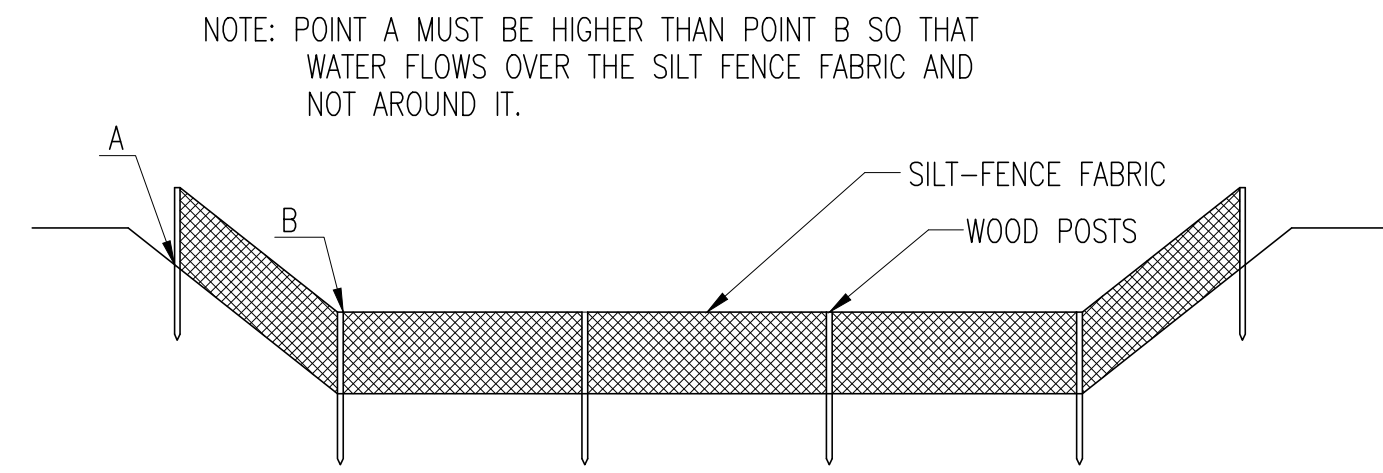

ELEVATION
SILT FENCE DITCH CHECKS
(STREAM PROTECTION)

MATERIAL SPECIFICATION:

SILT FENCE FABRIC SHOULD CONFORM TO THE AASHTO M288 96 SILT FENCE SPECIFICATION. THE POSTS USED TO SUPPORT THE SILT FENCE FABRIC SHOULD BE A HARDWOOD MATERIAL WITH THE FOLLOWING MINIMUM DIMENSIONS: 2" SQUARE (NOMINAL) BY 4' LONG. SILT FENCE FABRIC SHOULD BE ATTACHED TO THE WOODEN POSTS WITH STAPLES, WIRE, ZIP TIES, OR NAILS.

PLACEMENT:

PLACE SILT FENCE IN DITCHES WHERE IT IS UNLIKELY THAT IT WILL BE OVERTOPPED. WATER SHOULD FLOW THROUGH A SILT FENCE DITCH CHECK, NOT OVER IT. SILT FENCE DITCH CHECKS OFTEN FAIL WHEN OVERTOPPED. SILT FENCE DITCH CHECKS SHOULD BE PLACED PERPENDICULAR TO THE FLOWLINE OF THE DITCH. THE SILT FENCE SHOULD EXTEND FAR ENOUGH SO THAT THE GROUND LEVEL AT THE ENDS OF THE FENCE IS HIGHER THAN THE TOP OF THE LOW POINT OF THE FENCE. THIS PREVENTS WATER FROM FLOWING AROUND THE CHECK. SILT FENCE DITCH CHECKS SHOULD NOT BE PLACED IN DITCHES WHERE HIGH FLOWS ARE EXPECTED. ROCK CHECKS SHOULD BE USED INSTEAD. SILT FENCE SHOULD BE PLACED IN DITCHES WITH SLOPES OF 6% OR LESS. FOR SLOPES STEEPER THAN 6%, ROCK CHECKS SHOULD BE USED.

THE FOLLOWING TABLE PROVIDES CHECK SPACING FOR A GIVEN DITCH GRADE:

DITCH CHECK DITCH GRADE (%)	SPACING CHECK SPACING (FEET)
0.5	200
1.0	200
2.0	100
3.0	65
4.0	50
5.0	40
6.0	30

PROPER INSTALLATION METHOD:

EXCAVATE A TRENCH PERPENDICULAR TO THE DITCH FLOWLINE THAT IS AT LEAST 12" DEEP BY 6" WIDE. EXTEND THE TRENCH IN A STRAIGHT LINE ALONG THE ENTIRE LENGTH OF THE PROPOSED DITCH CHECK. PLACE THE SOIL ON THE UPSTREAM SIDE OF THE TRENCH FOR LATER USE. ROLL OUT A CONTINUOUS LENGTH OF SILT FENCE FABRIC ON THE DOWNSTREAM SIDE OF THE TRENCH. PLACE THE EDGE OF THE FABRIC IN THE TRENCH STARTING AT THE TOP UPSLOPE EDGE OF THE TRENCH. LINE TWO SIDES OF THE TRENCH WITH THE FABRIC AS SHOWN ON DETAIL. BACKFILL OVER THE FABRIC IN THE TRENCH WITH THE EXCAVATED SOIL AND COMPACT. AFTER FILLING THE TRENCH, APPROXIMATELY 24" TO 36" OF SILT FENCE FABRIC SHOULD REMAIN EXPOSED. LAY THE EXPOSED SILT FENCE ON THE UPSLOPE SIDE OF THE TRENCH TO CLEAR AN AREA FOR DRIVING IN THE POSTS. JUST DOWNSTREAM OF THE TRENCH, DRIVE POSTS INTO THE GROUND TO A DEPTH OF AT LEAST 24". PLACE POSTS NO MORE THAN 4' APART. ATTACH THE SILT FENCE TO THE ANCHORED POST WITH STAPLES, WIRE, ZIP TIES, OR NAILS.

LIST OF COMMON PLACEMENT/INSTALLATION MISTAKES TO AVOID:

WATER SHOULD FLOW THROUGH A SILT FENCE DITCH CHECK—NOT OVER IT. PLACE SILT FENCE IN DITCHES WHERE IT IS UNLIKELY THAT IT WILL BE OVERTOPPED. SILT FENCE INSTALLATIONS QUICKLY DETERIORATE WHEN WATER OVERTOPS THEM. DO NOT PLACE SILT FENCE POSTS ON THE UPSLOPE SIDE OF THE SILT FENCE FABRIC. IN THIS CONFIGURATION, THE FORCE OF THE WATER IS NOT RESTRICTED BY THE POSTS, BUT ONLY BY THE STAPLES (WIRE, ZIP TIES, NAILS, ETC.). THE SILT FENCE WILL RIP AND FAIL. DO NOT PLACE A SILT FENCE DITCH CHECK DIRECTLY IN FRONT OF A CULVERT OUTLET. IT WILL NOT STAND UP TO THE CONCENTRATED FLOW. DO NOT PLACE SILT FENCE DITCH CHECKS IN DITCHES THAT WILL LIKELY EXPERIENCE HIGH FLOWS. THEY WILL NOT STAND UP TO CONCENTRATED FLOW. FOLLOW PRESCRIBED DITCH CHECK SPACING GUIDELINES. IF SPACING GUIDELINES ARE EXCEEDED, EROSION WILL OCCUR BETWEEN THE DITCH CHECKS. DO NOT ALLOW WATER TO FLOW AROUND THE DITCH CHECK. MAKE SURE THAT THE DITCH CHECK IS LONG ENOUGH SO THAT THE GROUND LEVEL AT THE ENDS OF THE FENCE IS HIGHER THAN THE LOW POINT ON THE TOP OF THE FENCE. DO NOT PLACE SILT FENCE DITCH CHECKS IN CHANNELS WITH SHALLOW SOILS UNDERLAIN BY ROCK. IF THE CHECK IS NOT ANCHORED SUFFICIENTLY, IT WILL WASH OUT.

INSPECTION AND MAINTENANCE:

SILT FENCE DITCH CHECKS SHOULD BE INSPECTED EVERY 7 DAYS AND WITHIN 24 HOURS OF A RAINFALL OF 1/2" OR MORE. THE FOLLOWING IS A LIST OF QUESTIONS THAT SHOULD BE ADDRESSED DURING EACH INSPECTION:

- DOES WATER FLOW AROUND THE DITCH CHECK?
- DOES WATER FLOW UNDER THE DITCH CHECK?
- DOES THE SILT FENCE SAG EXCESSIVELY?
- HAS THE SILT FENCE TORN OR BECOME DETACHED FROM THE POSTS?
- DOES SEDIMENT NEED TO BE REMOVED FROM BEHIND THE DITCH CHECK?

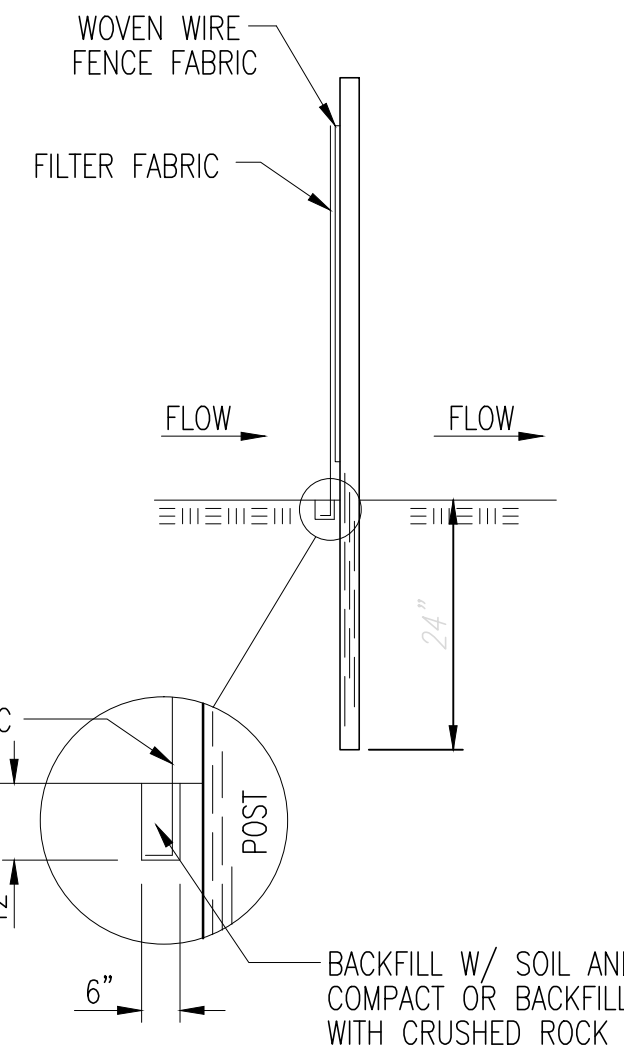

ANCHOR TRENCH DETAIL

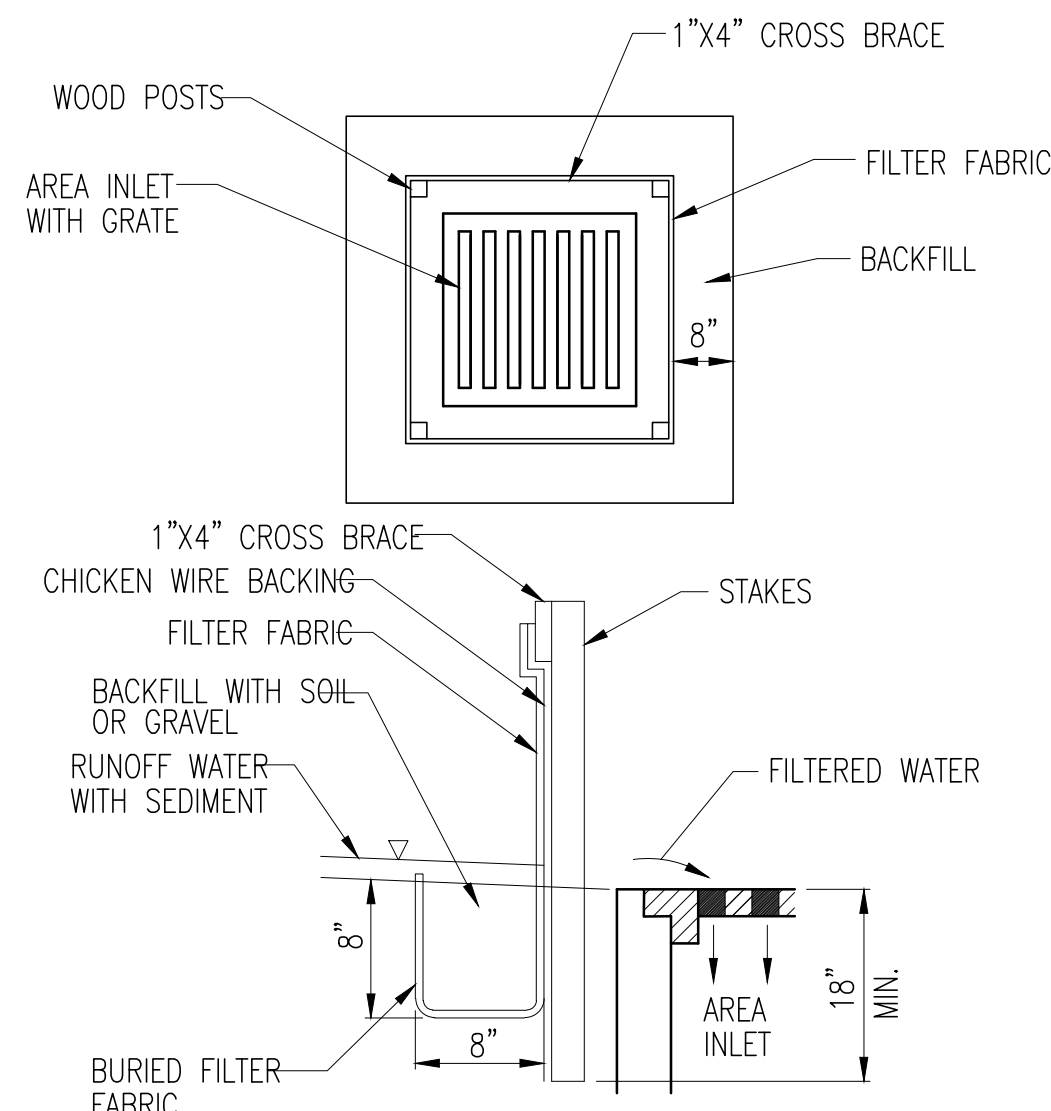

SILT FENCE BARRIERS FOR AREA INLETS
(INLET PROTECTION)

MATERIAL SPECIFICATION:

SILT FENCE FABRIC SHOULD CONFORM TO THE AASHTO M288 96 SILT FENCE SPECIFICATION. THE WIRE OR POLYMERIC MESH BACKING USED TO HELP SUPPORT THE SILT FENCE FABRIC SHOULD CONFORM TO THE AASHTO M288 96 SILT FENCE SPECIFICATION. THE POSTS USED TO SUPPORT THE SILT FENCE FABRIC SHOULD BE A HARDWOOD MATERIAL WITH THE FOLLOWING MINIMUM DIMENSIONS: 2" SQUARE (NOMINAL) BY 4' LONG. THE MATERIAL USED TO FRAME THE TOPS OF THE POSTS SHOULD BE 1" BY 4" BOARDS. SILT FENCE FABRIC AND SUPPORT BACKING SHOULD BE ATTACHED TO THE WOODEN POSTS AND FRAME WITH STAPLES, WIRE, ZIP TIES, OR NAILS.

PLACEMENT:

PLACE A SILT FENCE DROP INLET BARRIER IN A LOCATION WHERE IT IS UNLIKELY TO BE OVERTOPPED. WATER SHOULD FLOW THROUGH SILT FENCE, NOT OVER IT. SILT FENCE BARRIERS FOR AREA INLETS OFTEN FAIL WHEN REPEATEDLY OVERTOPPED. WHEN USED AS A BARRIER FOR AREA INLETS, SILT FENCE FABRIC AND POSTS MUST BE SUPPORTED AT THE TOP BY A WOODEN FRAME. WHEN A SILT FENCE BARRIER FOR AREA INLETS IS LOCATED NEAR AN INLET THAT HAS STEEP APPROACH SLOPES, THE STORAGE CAPACITY BEHIND THE BARRIER IS DRASTICALLY REDUCED. TIMELY REMOVAL OF SEDIMENT MUST OCCUR FOR A BARRIER TO OPERATE PROPERLY IN THIS LOCATION.

PROPER INSTALLATION METHOD:

EXCAVATE A TRENCH AROUND THE PERIMETER OF THE AREA INLET THAT IS AT LEAST 8" DEEP BY 8" WIDE. DRIVE POSTS TO A DEPTH OF AT LEAST 18" AROUND THE PERIMETER OF THE AREA INLET. THE DISTANCE BETWEEN POSTS SHOULD BE 4' OR LESS. IF THE DISTANCE BETWEEN TWO ADJACENT CORNER POSTS IS MORE THAN 4', ADD ANOTHER POST(S) BETWEEN THEM. CONNECT THE TOPS OF ALL THE POSTS WITH A WOODEN FRAME MADE OF 1" BY 4" BOARDS. USE NAILS OR SCREWS FOR FASTENING. ATTACH THE WIRE OR POLYMERIC-MESH BACKING TO THE OUTSIDE OF THE POST/FRAME STRUCTURE WITH STAPLES, WIRE, ZIP TIES, OR NAILS. ROLL OUT A CONTINUOUS LENGTH OF SILT FENCE FABRIC LONG ENOUGH TO WRAP AROUND THE PERIMETER OF THE AREA INLET. ADD MORE LENGTH FOR OVERLAPPING THE FABRIC JOINT. PLACE THE EDGE OF THE FABRIC IN THE TRENCH, STARTING AT THE OUTSIDE EDGE OF THE TRENCH. LINE ALL THREE SIDES OF THE TRENCH WITH THE FABRIC. BACKFILL OVER THE FABRIC IN THE TRENCH WITH THE EXCAVATED SOIL AND COMPACT. AFTER FILLING THE TRENCH, APPROXIMATELY 24" TO 36" OF SILT FENCE FABRIC SHOULD REMAIN EXPOSED. ATTACH THE SILT FENCE TO THE OUTSIDE OF THE POST/FRAME STRUCTURE WITH STAPLES, WIRE, ZIP TIES, OR NAILS. THE JOINT SHOULD BE OVERLAPPED TO THE NEXT POST.

NOTE: WHEN A SILT FENCE BARRIER FOR AREA INLET IS PLACED IN A SHALLOW MEDIAN DITCH, MAKE SURE THAT THE TOP OF THE BARRIER IS NOT HIGHER THAN THE PAVED ROAD. IN THIS CONFIGURATION, WATER MAY SPREAD ONTO THE ROADWAY CAUSING A HAZARDOUS CONDITION.

LIST OF COMMON PLACEMENT/INSTALLATION MISTAKES TO AVOID:

WATER SHOULD FLOW THROUGH A SILT FENCE BARRIER FOR AREA INLET—NOT OVER IT. PLACE A SILT FENCE BARRIER FOR AREA INLET IN A LOCATION WHERE IT IS UNLIKELY TO BE OVERTOPPED. SILT FENCE BARRIER FOR AREA INLETS OFTEN FAIL WHEN REPEATEDLY OVERTOPPED. DO NOT PLACE POSTS ON THE OUTSIDE OF THE SILT FENCE BARRIER FOR AREA INLET. IN THIS CONFIGURATION, THE FORCE OF THE WATER IS NOT RESTRICTED BY THE POSTS, BUT ONLY BY THE STAPLES (WIRE, ZIP TIES, NAILS, ETC.). THE SILT FENCE WILL RIP AND FAIL. DO NOT INSTALL SILT FENCE BARRIER FOR AREA INLETS WITHOUT FRAMING THE TOP OF THE POSTS. THE CORNER POSTS AROUND AREA INLETS ARE STRESSED IN TWO DIRECTIONS WHEREAS A NORMAL SILT FENCE IS ONLY STRESSED IN ONE DIRECTION. THIS ADDED STRESS REQUIRES MORE SUPPORT.

INSPECTION AND MAINTENANCE:

SILT FENCE BARRIER FOR AREA INLETS SHOULD BE INSPECTED EVERY 7 DAYS AND WITHIN 24 HOURS OF A RAINFALL OF 1/2" OR MORE. THE FOLLOWING IS A LIST OF QUESTIONS THAT SHOULD BE ADDRESSED DURING EACH INSPECTION:

- DOES WATER FLOW UNDER THE SILT FENCE?
- DOES THE SILT FENCE SAG EXCESSIVELY?
- HAS THE SILT FENCE TORN OR BECOME DETACHED FROM THE POSTS?
- DOES SEDIMENT NEED TO BE REMOVED FROM BEHIND THE AREA INLET BARRIER?

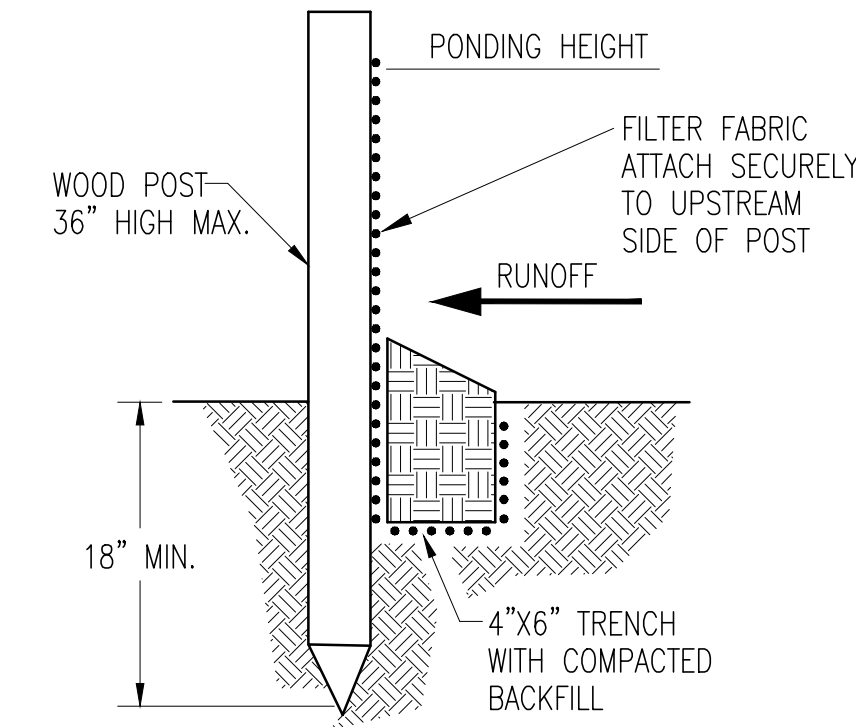

SILT FENCE BARRIERS

MATERIAL SPECIFICATION:

SILT FENCE FABRIC SHOULD CONFORM TO THE AASHTO M288 96 SILT FENCE SPECIFICATION. THE POSTS USED TO SUPPORT THE SILT FENCE FABRIC SHOULD BE A HARDWOOD MATERIAL WITH THE FOLLOWING MINIMUM DIMENSIONS: 2" SQUARE (NOMINAL) BY 4' LONG. SILT FENCE FABRIC SHOULD BE ATTACHED TO THE WOODEN POSTS WITH STAPLES, WIRE, ZIP TIES, OR NAILS.

PLACEMENT:

A SLOPE BARRIER SHOULD BE USED AT THE TOE OF A SLOPE WHEN A DITCH DOES NOT EXIST. THE SLOPE BARRIER SHOULD BE PLACED ON NEARLY LEVEL GROUND 5' TO 10' AWAY FROM THE TOE OF A SLOPE. THE BARRIER IS PLACED AWAY FROM THE TOE OF THE SLOPE TO PROVIDE ADEQUATE STORAGE FOR SETTLING OUT SEDIMENT. WHEN PRACTICABLE, SILT FENCE SLOPE BARRIERS SHOULD BE PLACED ALONG CONTOURS TO AVOID A CONCENTRATION OF FLOW. SILT FENCE SLOPE BARRIERS CAN ALSO BE PLACED ALONG RIGHT-OF-WAY FENCE LINES TO KEEP SEDIMENT FROM CROSSING ONTO ADJACENT PROPERTY. WHEN PLACED IN THIS MANNER, THE SLOPE BARRIER WILL NOT LIKELY FOLLOW CONTOURS.

PROPER INSTALLATION METHOD:

EXCAVATE A TRENCH THE LENGTH OF THE PLANNED SLOPE BARRIER THAT IS 6" DEEP BY 4" WIDE. MAKE SURE THAT THE TRENCH IS EXCAVATED ALONG A SINGLE CONTOUR. WHEN PRACTICABLE, SLOPE BARRIERS SHOULD BE PLACED ALONG CONTOURS TO AVOID A CONCENTRATION OF FLOW. PLACE THE SOIL ON THE UPSLOPE SIDE OF THE TRENCH FOR LATER USE. ROLL OUT A CONTINUOUS LENGTH OF SILT FENCE FABRIC ON THE DOWNSLOPE SIDE OF THE TRENCH. PLACE THE EDGE OF THE FABRIC IN THE TRENCH STARTING AT THE TOP UPSLOPE EDGE. LINE ALL THREE SIDES OF THE TRENCH WITH THE FABRIC. BACKFILL OVER THE FABRIC IN THE TRENCH WITH THE EXCAVATED SOIL AND COMPACT. AFTER FILLING THE TRENCH, APPROXIMATELY 24" TO 36" OF SILT-FENCE FABRIC SHOULD REMAIN EXPOSED. LAY THE EXPOSED SILT FENCE UPSLOPE OF THE TRENCH TO CLEAR AN AREA FOR DRIVING IN THE POSTS. JUST DOWNSLOPE OF THE TRENCH, DRIVE POSTS INTO THE GROUND TO A DEPTH OF AT LEAST 18". PLACE POSTS NO MORE THAN 4' APART. ATTACH THE SILT FENCE TO THE ANCHORED POST WITH STAPLES, WIRE, ZIP TIES, OR NAILS.

LIST OF COMMON PLACEMENT/INSTALLATION MISTAKES TO AVOID:

WHEN PRACTICABLE, DO NOT PLACE SILT FENCE SLOPE BARRIERS ACROSS CONTOURS. SLOPE BARRIERS SHOULD BE PLACED ALONG CONTOURS TO AVOID A CONCENTRATION OF FLOW. WHEN THE FLOW CONCENTRATES, IT OVERTOPS THE BARRIER AND THE SILT FENCE SLOPE BARRIER QUICKLY DETERIORATES. DO NOT PLACE SILT-FENCE POSTS ON THE UPSLOPE SIDE OF THE SILT FENCE FABRIC. IN THIS CONFIGURATION, THE FORCE OF THE WATER IS NOT RESTRICTED BY THE POSTS, BUT ONLY BY THE STAPLES (WIRE, ZIP TIES, NAILS, ETC.). THE SILT FENCE WILL RIP AND FAIL. DO NOT PLACE SILT FENCE SLOPE BARRIERS IN AREAS WITH SHALLOW SOILS UNDERLAIN BY ROCK. IF THE BARRIER IS NOT SUFFICIENTLY ANCHORED, IT WILL WASH OUT. SILT FENCE SLOPE BARRIERS MUST BE DUG INTO THE GROUND—SILT FENCE AT GROUND LEVEL DOES NOT WORK BECAUSE WATER WILL FLOW UNDERNEATH.

INSPECTION AND MAINTENANCE:

SILT FENCE SLOPE BARRIERS SHOULD BE INSPECTED EVERY 7 DAYS AND WITHIN 24 HOURS OF A RAINFALL OF 1/2" OR MORE. THE FOLLOWING IS A LIST OF QUESTIONS THAT SHOULD BE ADDRESSED DURING EACH INSPECTION:

- ARE THERE ANY POINTS ALONG THE SLOPE BARRIER WHERE WATER IS CONCENTRATING?
- DOES WATER FLOW UNDER THE SLOPE BARRIER?
- DO THE SILT FENCES SAG EXCESSIVELY?
- HAS THE SILT FENCE TORN OR BECOME DETACHED FROM THE POSTS?
- DOES SEDIMENT NEED TO BE REMOVED FROM BEHIND THE SLOPE BARRIER?

SILT FENCE DITCH CHECK AND BARRIER DETAILS

CITY ENGINEER JAMES L. ARMOUR, P.E., L.S.		
PROJECT NUMBER —	OCA NUMBER —	DATE 11/2010
CITY ENGINEER'S OFFICE CITY HALL - SEVENTH FLOOR 455 NORTH MAIN STREET WICHITA, KANSAS 67202-1620 (316) 268-4501		DESIGN DRAWN
SHEET — of —		

KIA ADDITION KELLOGG & TYLER WATER DISTRIBUTION SYSTEM IMPROVEMENTS EROSION CONTROL DETAILS CITY OF WICHITA, KANSAS GARY JANZEN, P.E. - CITY ENGINEER C.O.M. Proj.# 1708-PPW O.C.A.# 607853	POE & ASSOCIATES, INC. CONSULTING ENGINEERS 5940 E. Central, Suite 200 ■ Wichita, KS 67208-4242 Phone 316/685-4111 ■ FAX 316/685-4444	Professional Engineer Seal for Gary Janzen, No. 11/20/12	Approved By Date No.
---	--	--	-------------------------------

WICHITA
Engineer: S. SERVIS
Designer: S. SERVIS
Drawing: P: 102020-BasesW.L.dwg
Date: 12/14/2012
Sheet 7 of 11

GENERAL NOTES

- THIS SHEET IS INTENDED TO PROVIDE GUIDELINES AS TO WHAT TYPES OF EROSION CONTROL DEVICES WILL BE INSTALLED DURING THE CONSTRUCTION PROCESS. CONTRACTORS ARE EXPECTED TO BID PROJECTS ACCORDINGLY.
- EROSION CONTROL DEVICES MUST BE MAINTAINED BY THE CONTRACTOR THROUGHOUT THE CONSTRUCTION PROCESS AND UNTIL THE DISTURBED EARTH IS RESTABILIZED.
- IF THE PROJECT WILL DISTURB 1 ACRE OR MORE, A FEDERAL/STATE NPDES STORMWATER PERMIT IS REQUIRED. A DETAILED STORMWATER POLLUTION PREVENTION PLAN, IS REQUIRED. THE EROSION CONTROL DEVICES SHOWN ON THIS SHEET ARE CONSIDERED TO BE THE MINIMUM TO BE SHOWN IN THE POLLUTION PREVENTION PLAN.
- FOR PROJECTS DISTURBING LESS THAN 1 ACRE, CONTRACTORS ARE ENCOURAGED TO PREPARE STORMWATER POLLUTION PREVENTION PLANS PRIOR TO CONSTRUCTION. EROSION CONTROL DEVICES MUST BE USED ON ALL PROJECTS.
- FAILURE TO USE AND MAINTAIN EROSION CONTROL DEVICES IS A VIOLATION OF SECTION 16.32 OF THE CITY CODE AND WILL SUBJECT THE CONTRACTOR TO THE PENALTIES PROVIDED FOR THEREIN.
- THE APPLICATION OF EROSION CONTROL DEVICES SHOWN ON THIS SHEET IS FOR SITUATIONS NORMALLY ENCOUNTERED. FROM TIME TO TIME, SITUATIONS WILL ARISE THAT MAY REQUIRE A DIFFERENT DEVICE OTHER THAN THOSE SHOWN. EROSION CONTROL DEVICES, OTHER THAN THOSE SHOWN, MAY BE UTILIZED AS LONG AS THEY ARE EFFECTIVE AND MAINTAINED.

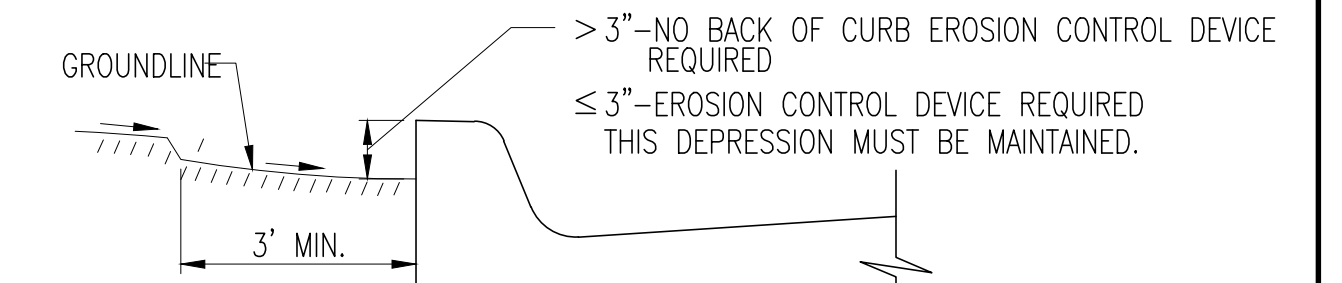

CURB BACKFILL DETAIL

THIS IS A TEMPORARY MEASURE ONLY, WHEN APPROVED BY THE PROJECT ENGINEER. THE DIRT GRADE BEHIND THE CURB SHALL BE BROUGHT TO THE TOP OF CURB, WITH TEMPORARY EROSION CONTROL MAT OR PERMANENT VEGETATION PLACED, PRIOR TO THE COMPLETION OF ALL PROJECTS.

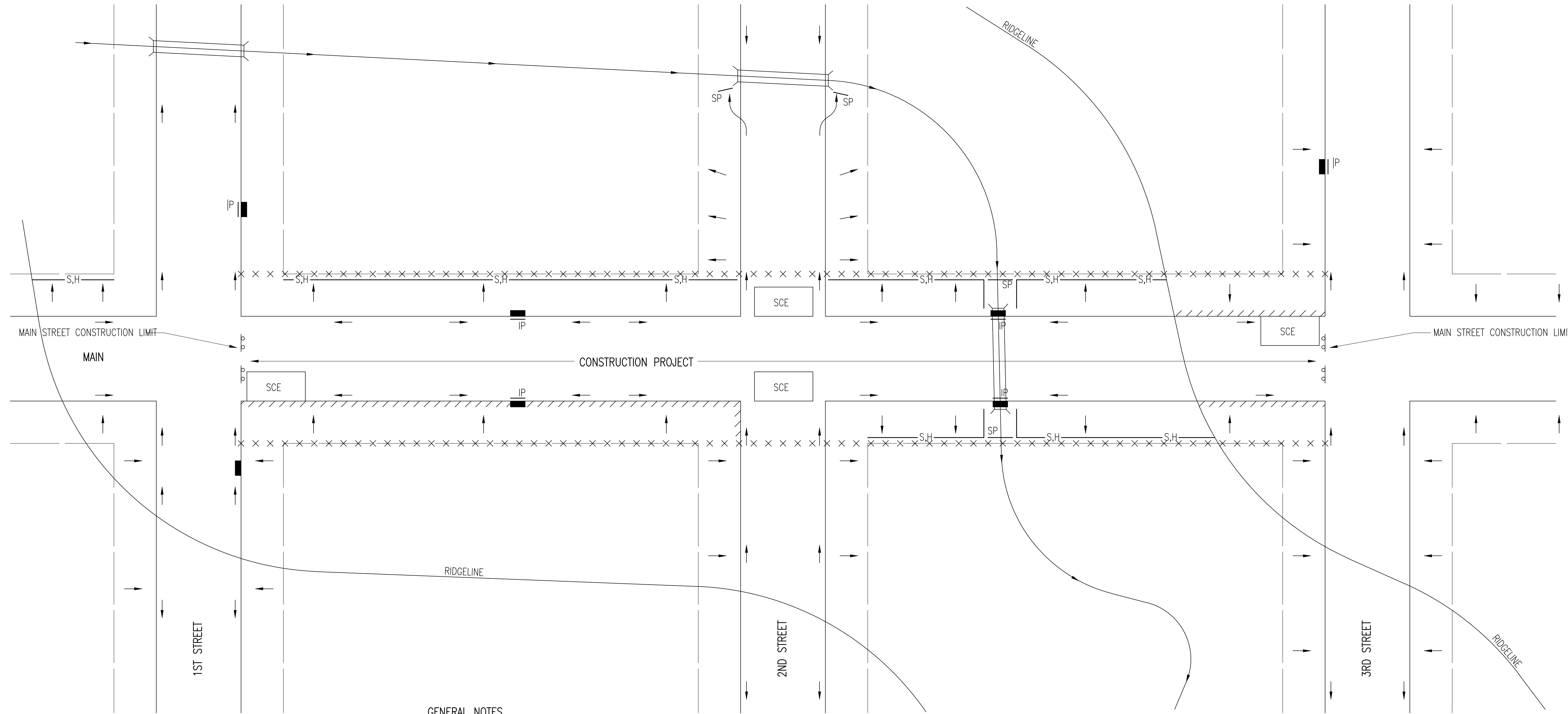

LEGEND

- R-O-W LIMITS
- DRAINAGE FLOW PATH
- × × × × R/W LIMIT WITHIN CONSTRUCTION LIMIT
- STORM WATER INLETS
- IP INLET PROTECTION
- S,H— SILT FENCE OR HAY BALE BARRIER
- SP STREAM PROTECTION
- SCE STABILIZED CONSTRUCTION ENTRANCE
- //// BACK OF CURB PROTECTION

GENERAL NOTES

- THE INTENT OF ALL EROSION CONTROL DEVICES IS TO KEEP ALL SEDIMENT CONFINED TO THE CONSTRUCTION SITE, AND OUT OF ALL UNDERGROUND PIPES, DITCHES, LAKES, AND OTHER DRAINAGE FACILITIES, AND OFF OF STREETS.
- THE POINT OF COMPLIANCE IS GENERALLY THE RIGHT-OF-WAY LIMITS WITHIN THE LIMITS OF CONSTRUCTION.
- EROSION CONTROL DEVICES WILL BE REQUIRED AT ALL POINTS ALONG THE PROJECT WHERE DISTURBED EARTH CAN DRAIN ONTO PRIVATE PROPERTY.
- INLET PROTECTION DEVICES WILL BE REQUIRED WHEREVER WATER CAN DRAIN OFF THE PROJECT SITE INTO AN INLET, INCLUDING ANY SIDE STREET INLETS.
- EROSION CONTROL DEVICES SHALL BE INSTALLED AT CREEK CROSSINGS SO AS TO PREVENT SEDIMENT FROM ENTERING THEREIN.
- STABILIZED CONSTRUCTION ENTRANCES SHALL BE PROVIDED, AS NEEDED, TO PREVENT MUD FROM TRACKING ONTO STREETS NOT UNDER CONSTRUCTION AND ON STREETS WITHIN THE PROJECT LIMITS IF TRAFFIC IS BEING MAINTAINED THROUGH THE PROJECT.
- ANY MUD TRACKED ONTO STREETS MUST BE REMOVED AT THE END OF EACH WORK DAY.
- THE CONTRACTOR WILL BE REQUIRED TO PLACE EROSION CONTROL DEVICES BACK OF CURB, WHENEVER WATER CAN DRAIN OVER CURB, TO KEEP ERODED SOIL OUT OF THE GUTTERLINES, IN ACCORDANCE WITH THE FOLLOWING:
 - THE DEVICE REQUIRED WILL BE APPROVED EROSION CONTROL MAT LISTED ON THE CITY'S APPROVED MATERIAL LIST. SAID BLANKET SHALL BE PLACED OVER THE APPROPRIATE SEED AND FERTILIZER, AS SPECIFIED IN THE PROJECT SPECIFICATIONS. (SEE SOIL EROSION BMPs - BACK OF CURB SEDIMENT BARRIER DETAILS)
 - THIS DEVICE SHALL BE INSTALLED IMMEDIATELY WHENEVER THE CURB IS BACKFILLED TO WITHIN 3" OF THE TOP OF CURB. (SEE CURB BACKFILL DETAIL) OTHER BMP'S MAY BE REQUIRED AT LOCATIONS WHERE CONCENTRATED FLOW CARRIES SEDIMENT OVER THE CURB.
 - ADDITIONALLY, OTHER EROSION CONTROL DEVICES (HAY BALES, SILT FENCE, ETC.) WILL BE INSTALLED AT LOCATIONS OF CONCENTRATED FLOW RESULTING IN SEDIMENT OVERRUNNING THE MAT.
 - SHOULD THE PROJECT PLANS SPECIFY THAT THE RIGHT-OF-WAY IS TO BE SODDED, THE EXCELSIOR MAT WILL NOT BE REQUIRED SO LONG AS THE SOD IS PLACED WITHIN 48 HOURS AFTER CURB BACKFILL REACHES A HEIGHT OF 3" OR LESS FROM TOP OF CURB. (SEE CURB BACKFILL DETAIL)



STREET IMPROVEMENT PROJECTS		
INTERIM CITY ENGINEER GARY JANZEN, P.E.		
PROJECT NUMBER	OCA NUMBER	DATE
		08/2012
CITY ENGINEER'S OFFICE CITY HALL - SEVENTH FLOOR 455 NORTH MAIN STREET WICHITA, KANSAS 67202-1620 (316) 268-4501		DESIGN DRAWN
SHEET		DATE
_ of _		12/14/2012

No.	Date	By	Approved	Revision
1				
KIA ADDITION KELLOGG & TYLER WATER DISTRIBUTION SYSTEM IMPROVEMENTS EROSION CONTROL DETAILS CITY OF WICHITA, KANSAS GARY JANZEN, P.E. - CITY ENGINEER C.D.M. Proj.# 1708 PPW O.C.A.# 607853				
POE & ASSOCIATES, INC. CONSULTING ENGINEERS 5940 E. Central, Suite 200 • Wichita, KS 67208-4242 Phone 316.685-1114 • FAX 316.685-4444				
11/20/12				
9 of 11				

PHASE 1 – INITIAL EARTHWORK AND UTILITIES (EXCEPT STORM SEWER)

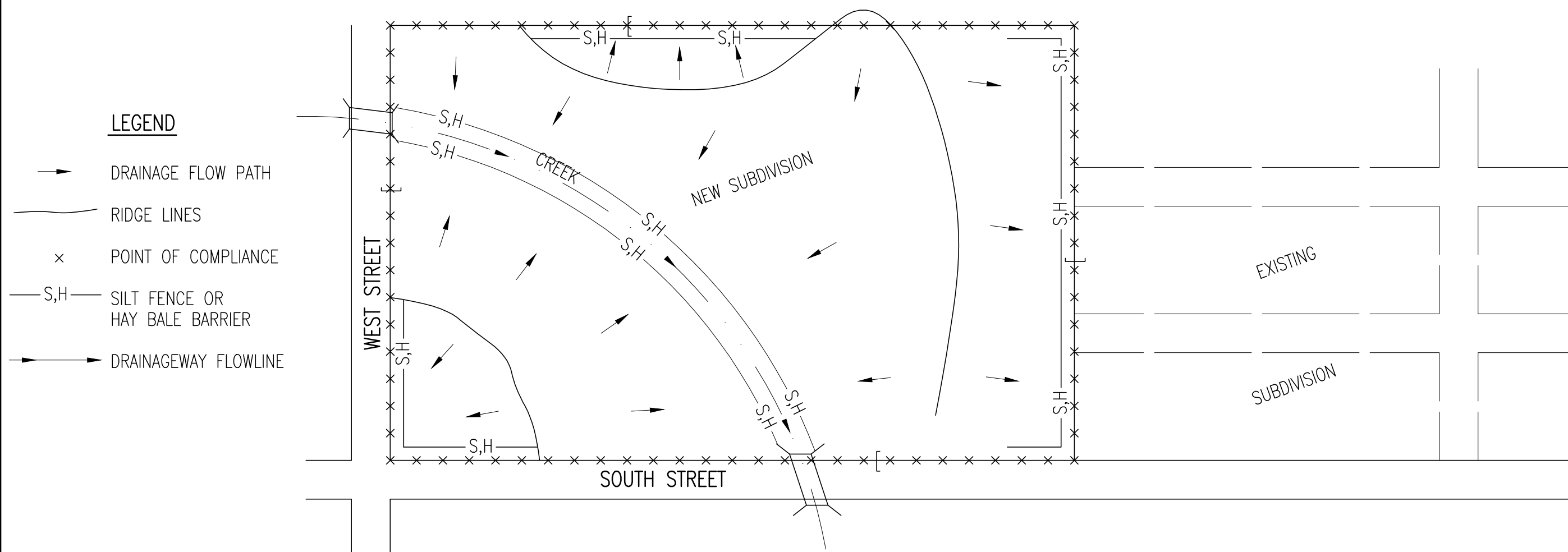

- LEGEND**
- DRAINAGE FLOW PATH
 - RIDGE LINES
 - × POINT OF COMPLIANCE
 - S,H SILT FENCE OR HAY BALE BARRIER
 - DRAINAGEWAY FLOWLINE
- DURING THIS PHASE OF SUBDIVISION CONSTRUCTION, THE POINTS OF COMPLIANCE ARE THE PERIMETER BOUNDARIES AND ANY DRAINAGE WAYS OR STORM SEWERS DRAINING THROUGH OR FROM THE SITE. SHOULD LAKES BE CONSTRUCTED WITHIN THE SUBDIVISION THAT WILL DISCHARGE DURING STORMS, THEY ARE ALSO A POINT OF COMPLIANCE.
 - HAY BALES OR SILT FENCE MUST BE CONSTRUCTED ALONG THE PROPERTY LINE WHERE ON SITE WATER CAN DRAIN OFF THE PROPERTY. THESE EROSION CONTROL DEVICES WILL ALSO BE INSTALLED ALONG ANY DRAINAGE DITCH OR LAKE THAT CAN DISCHARGE.
 - SHOULD SILT OR SEDIMENT ENTER THE DITCHES OR STREETS ON THE ADJACENT BOUNDARY STREETS, APPROPRIATE EROSION CONTROL DEVICES WILL BE PLACED WITHIN THE SUBDIVISION TO PREVENT THIS.
 - ANY MUD TRACKED ONTO ADJACENT STREETS WILL BE REMOVED WITHIN 48 HOURS OR BY FRIDAY AT 6:00 PM, WHICHEVER IS EARLIER.
 - CONTRACTORS WORKING WITHIN THE SITE WILL NOT BE REQUIRED TO USE INDIVIDUAL EROSION CONTROL DEVICES AS LONG AS THOSE SPECIFIED ABOVE ARE IN PLACE AND EFFECTIVE. CONTRACTORS WORKING ON THE BOUNDARY LINE STREETS OR ON ADJACENT PROPERTIES TO EXTEND UTILITIES ARE EXPECTED TO USE EROSION CONTROL DEVICES AT THEIR WORK LOCATIONS, AS NEEDED.
 - UTILIZE STABILIZED CONSTRUCTION ENTRANCE AT ENTRANCE AND EXIT ONTO ANY EXISTING PUBLIC STREETS.
 - IF THE INITIAL EARTH WORK AND UTILITIES ARE DONE AS PART OF A PUBLIC IMPROVEMENT PROJECT, THESE EROSION CONTROL DEVICES WILL BE INSTALLED BY THE CONTRACTOR AS SPECIFIED IN THE INDIVIDUAL PROJECT CONTRACTS. THE CONTRACTOR WILL MAINTAIN THE DEVICES UNTIL COMPLETION OF THE CONTRACT, AT WHICH TIME THE DEVELOPER WILL ASSUME MAINTENANCE RESPONSIBILITIES. IF THESE CONTRACTS ARE NOT PUBLIC IMPROVEMENT PROJECTS, THE DEVELOPER WILL BE RESPONSIBLE FOR INSTALLING AND MAINTAINING THESE DEVICES.
 - WITHIN 14 DAYS OF COMPLETION OF EARTHWORK ACTIVITIES IN ANY GIVEN AREA, THAT AREA SHALL BE TEMPORARILY OR PERMANENTLY SEEDED AND MULCHED.

PHASE 2 – INSTALLATION OF STORM SEWER

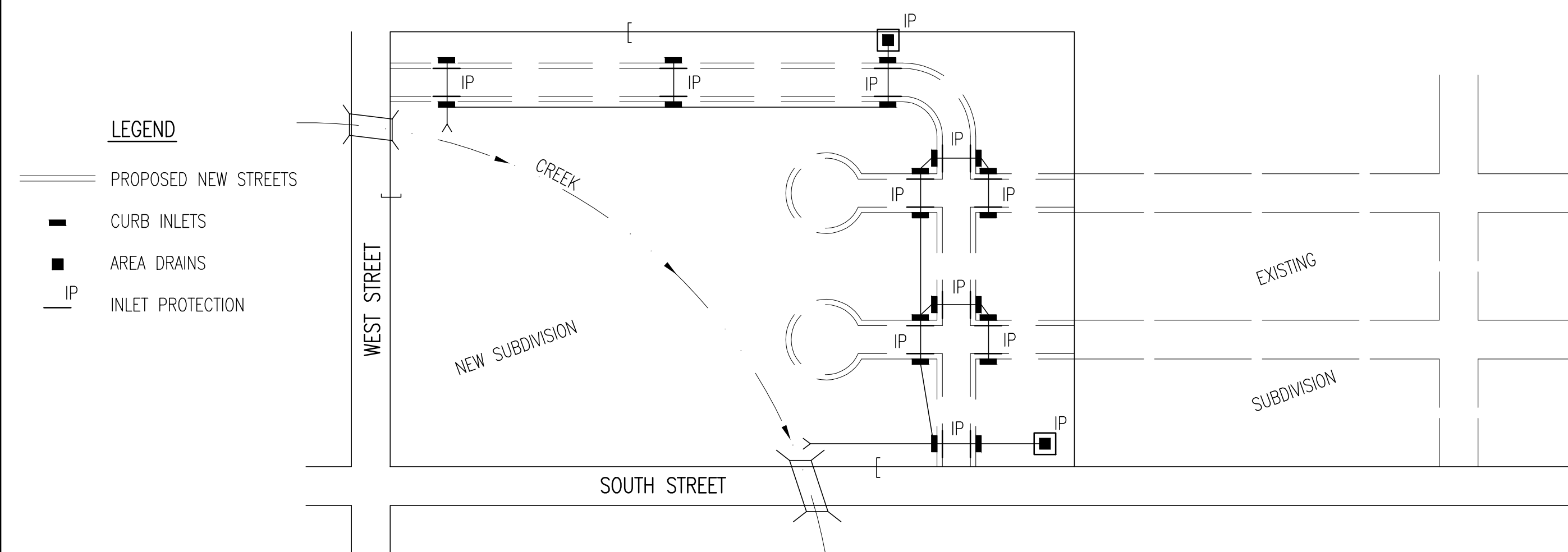

- LEGEND**
- PROPOSED NEW STREETS
 - CURB INLETS
 - AREA DRAINS
 - IP INLET PROTECTION
- DURING THIS PHASE OF SUBDIVISION DEVELOPMENT, ALL EROSION CONTROL DEVICES REQUIRED IN PHASE 1 SHALL REMAIN IN PLACE AND BE MAINTAINED.
 - AS NEW STORM SEWERS, WITH INLETS, ARE INSTALLED, THE STORM SEWERS MUST NOW BE PROTECTED SO ALL NEW INLETS BECOME POINTS OF COMPLIANCE.
 - AREA DRAINS – AS SOON AS WATER CAN FLOW INTO THESE DRAINS, HAY BALE OR SILT FENCE PROTECTION WILL BE INSTALLED AROUND THEM.
 - CURB OPENING INLETS – AS SOON AS WATER CAN FLOW INTO THESE DRAINS, INLET PROTECTION DEVICES MUST BE INSTALLED. IF WATER CANNOT FLOW INTO CURB INLETS UNTIL STREET CONSTRUCTION IS COMPLETE, THEN STREET CONTRACTOR WILL INSTALL INLET PROTECTION. SEE PHASE 3 – STREET CONSTRUCTION.
 - THE STORM SEWER CONTRACTOR WILL BE RESPONSIBLE FOR INSTALLING THESE DEVICES.
 - THE SUBDIVISION DEVELOPER WILL MAINTAIN THESE EROSION CONTROL DEVICES ONCE INSTALLED.
 - ALL DISTURBED GROUND WILL BE FINAL GRADED AND TEMPORARILY OR PERMANENTLY SEEDED WITHIN 14 DAYS IF COMPLETION OF WORK IN ANY GIVEN PART OF THE SUBDIVISION.
 - ONCE ALL DISTURBED GROUND DRAINING TO AN INLET HAS BEEN RESTABILIZED WITH GRASS OR SOD, THE SUBDIVISION DEVELOPER WILL BE RESPONSIBLE FOR PERMANENTLY REMOVING THE INLET PROTECTION.

PHASE 3 – STREET CONSTRUCTION

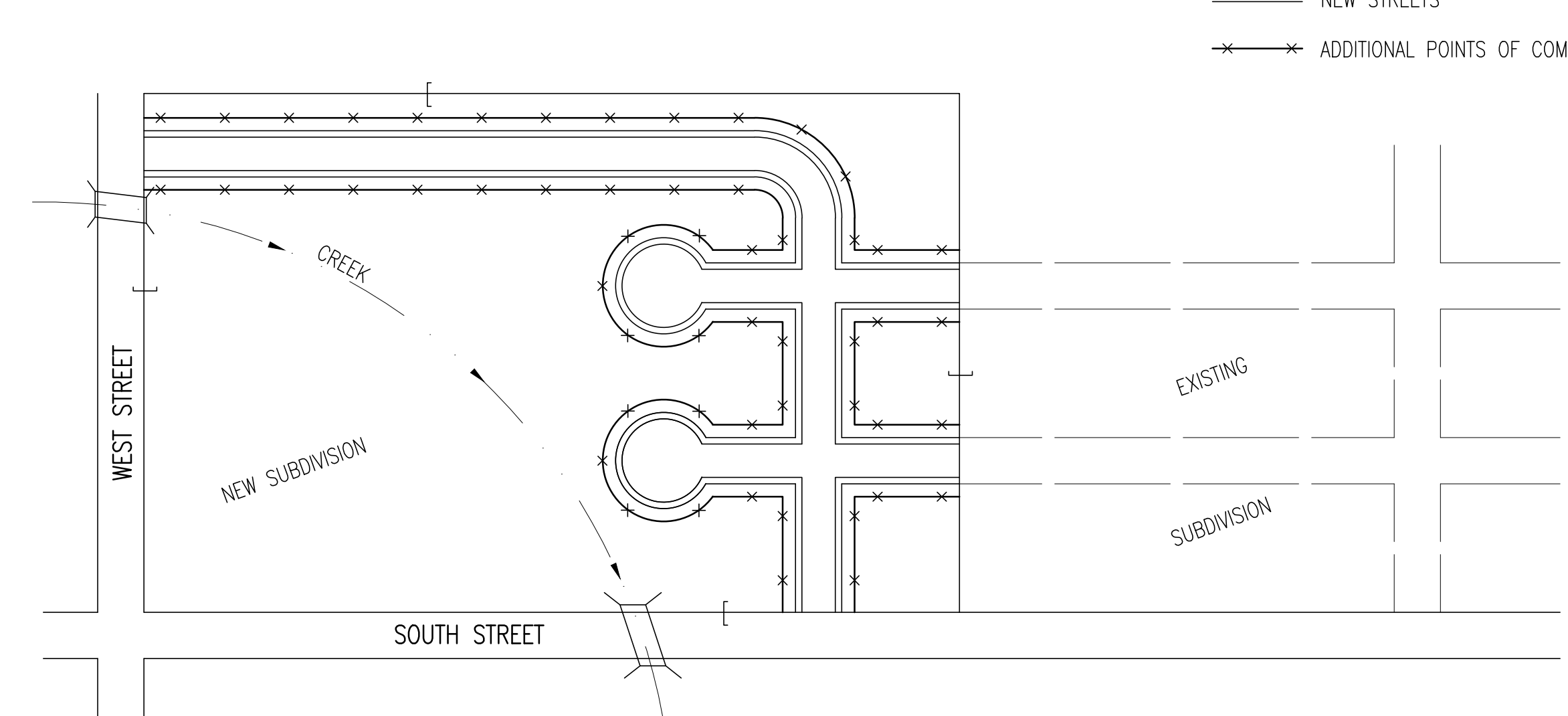

- LEGEND**
- NEW STREETS
 - × ADDITIONAL POINTS OF COMPLIANCE
- DURING THIS PHASE OF SUBDIVISION CONSTRUCTION, NEW STREETS ARE INSTALLED. ALL EROSION CONTROL DEVICES INSTALLED DURING PHASE 1 AND 2 MUST STILL BE MAINTAINED. THE POINT OF COMPLIANCE NOW SHIFTS TO THE BACK OF CURB ALONG EACH STREET.
 - CURB OPENING INLET PROTECTION:
 - A. SUMP AREAS – INLET PROTECTION SHALL BE PROVIDED WHEN STREET SUBGRADE WORK IS COMPLETED.
 - B. NON-SUMP LOCATIONS – PROVIDE INLET PROTECTION AS SOON AS BASE COURSE ASPHALT IS INSTALLED, BEFORE THE SURFACE COURSE LIFT.
 - EROSION CONTROL DEVICES WILL BE REQUIRED BACK OF CURB WHEREVER WATER CAN FLOW OVER THE CURB AND THE CURB HAS BEEN BACKFILLED TO WITHIN 3" OR LESS OF THE TOP OF CURB (SEE CURB BACKFILL DETAIL). FOR CURBS NOT YET ENTIRELY BACKFILLED (3" OR MORE BELOW TOP OF CURB), ADDITIONAL DEVICES WILL BE REQUIRED AT POINTS WHERE WATER BREAKS OVER CURB WHICH COULD RESULT IN THE PLACEMENT OF SEDIMENT IN THE GUTTER.
 - SEE DETAIL SHEET FOR BACK OF CURB PROTECTION.
 - THE BACK OF CURB PROTECTION SPECIFIED ON THIS PLAN MAY HAVE TO BE SUPPLEMENTED WITH HAY BALE OR SILT FENCE EROSION CONTROL DEVICES AT LOCATIONS WHERE CONCENTRATED FLOW RESULTS IN SEDIMENT BEING CARRIED OVER THE EXCELSIOR MATS.
 - THE STREET CONTRACTOR WILL BE RESPONSIBLE FOR INSTALLING BACK OF CURB EROSION CONTROL DEVICES.
 - THE INDIVIDUAL LOT OWNERS WILL BE RESPONSIBLE FOR MAINTAINING THE BACK OF CURB EROSION CONTROL DEVICES IN FRONT OF THEIR LOTS UNTIL SUCH TIME AS ADJACENT DISTURBED EARTH IS STABILIZED WITH GRASS OR SOD.

GENERAL NOTES

- THE INTENT OF ALL EROSION CONTROL DEVICES IS TO PREVENT ERODED SOIL FROM ENTERING DITCHES, STORM SEWERS, LAKES, STREETS OR ANY OTHER OTHER DRAINAGE FEATURE.
- THIS SHEET IS INTENDED TO PROVIDE GUIDELINES AS TO WHAT TYPE OF EROSION CONTROL DEVICES WILL BE INSTALLED DURING THE CONSTRUCTION PROCESS. CONTRACTORS ARE EXPECTED TO BID PROJECTS ACCORDINGLY.
- EROSION CONTROL DEVICES SHALL BE MAINTAINED DURING THE CONSTRUCTION PROCESS TO REMAIN EFFECTIVE. MAINTENANCE SHALL BE AS INDICATED ON SOIL EROSION BMP'S DETAIL SHEETS.
- PERSONS DESTROYING EROSION CONTROL DEVICES SHALL BE RESPONSIBLE FOR IMMEDIATELY REPAIRING THEM OR INSTALLING SUITABLE REPLACEMENT DEVICES.
- THE DEVELOPMENT OF ANY SUBDIVISION THAT DISTURBS 1 ACRE OR MORE WILL REQUIRE A FEDERAL/STATE NPDES STORMWATER PERMIT. THE PREPARATION OF A STORMWATER POLLUTION PREVENTION PLAN IS REQUIRED. EROSION CONTROL DEVICES ARE REQUIRED. THE DETAILS SHOWN ON THIS SHEET ARE THE MINIMUM STANDARDS TO BE SHOWN ON POLLUTION PREVENTION PLANS.
- FOR SUBDIVISIONS SMALLER THAN 1 ACRE, SOIL EROSION DEVICES ARE REQUIRED. ALSO, DEVELOPERS AND CONTRACTORS ARE ENCOURAGED TO DEVELOP POLLUTION PREVENTION PLANS FOR EACH PROJECT PRIOR TO CONSTRUCTION.
- FAILURE TO USE AND MAINTAIN SOIL EROSION DEVICES IS A VIOLATION OF SECTION 16.32 OF THE CITY CODE AND WILL SUBJECT THE SUBDIVISION DEVELOPER AND CONTRACTORS TO THE PENALTIES PROVIDED THEREIN.
- THE APPLICATION OF EROSION CONTROL DEVICES SHOWN ON THIS SHEET IS FOR SITUATIONS NORMALLY ENCOUNTERED. FROM TIME TO TIME, SITUATIONS WILL ARISE THAT MAY REQUIRE DEVICES OTHER THAN THAT SHOWN. EROSION CONTROL DEVICES, OTHER THAN THOSE SHOWN, MAY BE UTILIZED SO LONG AS THEY ARE EFFECTIVE AND MAINTAINED.
- A STABILIZED EARTH SURFACE IS DEFINED AS ONE THAT IS HARD SURFACED WITH CONCRETE, ASPHALT, OR THE LIKE, OR ONE ON WHICH 70% OF THE GRASS HAS GERMINATED ON THE ENTIRE SURFACE.

SEE DETAIL SHEET FOR BACK OF CURB PROTECTION DETAIL

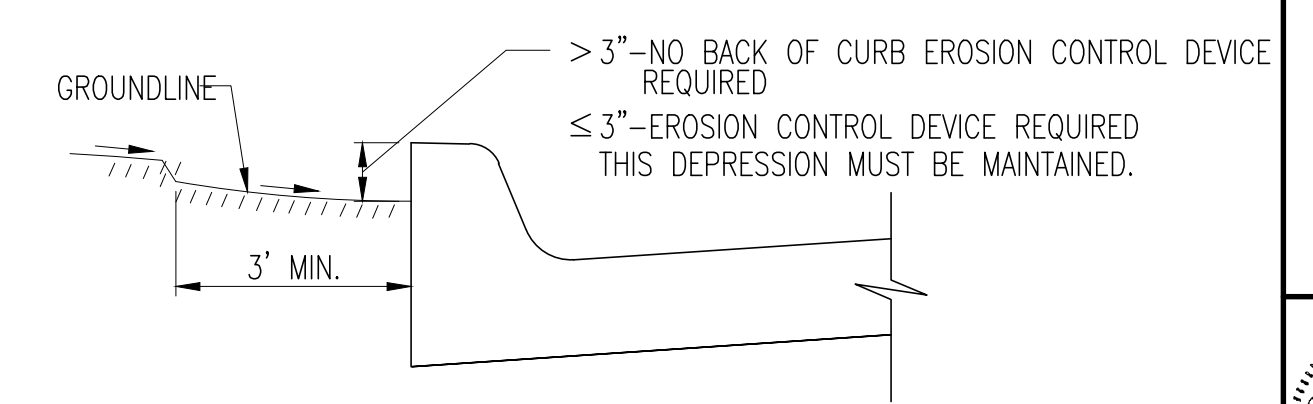

CURB BACKFILL DETAIL (STREET CONSTRUCTION ONLY)

THIS IS A TEMPORARY MEASURE ONLY, WHEN APPROVED BY THE PROJECT ENGINEER. THE DIRT GRADE BEHIND THE CURB SHALL BE BROUGHT TO THE TOP OF CURB, WITH TEMPORARY EROSION CONTROL MAT OR PERMANENT VEGETATION PLACED, PRIOR TO THE COMPLETION OF ALL PROJECTS.



SUBDIVISION DEVELOPMENT PROCESS

INTERIM CITY ENGINEER
GARY JANZEN, P.E.

PROJECT NUMBER	OCA NUMBER	DATE
		08/2012

CITY ENGINEER'S OFFICE
 CITY HALL - SEVENTH FLOOR
 455 NORTH MAIN STREET
 WICHITA, KANSAS 67202-1620
 (316) 268-4501

DESIGN DRAWN
 SHEET
 of

No.	Date	By	Approved/Revision

KIA ADDITION
 KELLOGG & TYLER
 WATER DISTRIBUTION SYSTEM IMPROVEMENTS
 EROSION CONTROL DETAILS
 CITY OF WICHITA, KANSAS
 GARY JANZEN, P.E. – CITY ENGINEER
 C.O.M. Proj.# 1708-PFW O.C.A.# 607853

POE & ASSOCIATES, INC.
 CONSULTING ENGINEERS
 5940 E. Central, Suite 200 • Wichita, KS 67208-4242
 Phone 316.685-4114 • FAX 316.685-4444

11/20/12

WICHA
 Engineer: S. SERVIS
 Designer: S. SERVIS
 Drawing: P:\102020\Bases\W.L.dwg
 Date: 12/14/2012

Sheet
 10 of 11

KIA ADDITION

WICHITA, SEDGWICK COUNTY, KANSAS

State of Kansas) SS
Sedgwick County)

We, Savoy Company, P.A., Surveyors in aforesaid county and state do hereby certify that, under the supervision of the undersigned, we have surveyed and platted "KIA ADDITION", Wichita, Sedgwick County, Kansas and that the accompanying plat is a true and correct exhibit of the property surveyed, described as, and being a replat of:

That part of Lots 25 and 26 Fairlawn Acres, Sedgwick County, Kansas, described as Beginning at a point on the South line of the North 138 feet of Lot 25, said point being 35 feet East of the West line of said Lot 25 and on the East line of the Right-of-Way Agreement recorded at Film 2147, Page 940; thence Northeasterly, along the East line of said Right-of-Way Agreement, a distance of 138.90 feet to a point on the South line of said Lot 26, said point being 50.0 feet East of the West line of said Lot 26; thence North, parallel with and 50.0 feet East of the West line of said Lot 26, a distance of 234.5 feet more or less to a point on the South line of U.S. 54 Highway Right-of-Way as Condemned in Case No.A-38302; thence Northeasterly along said Case No.A-38302, 262.8 feet more or less to a point 5.0 feet South of the North line of said Lot 26, said point being the South line of the Street Dedication recorded at Film 404, Page 632; thence East along said Street Dedication, 150.0 feet; thence North parallel with the West line of said Lot 26, 5.0 feet to a point on the North line of said Lot 26; thence East along the North line of said Lot 26, 191.39 feet to the Northeast corner of said Lot 26; thence South along the East line of said Lots 26 and 25, 483.0 feet to the Southeast corner of the North 138.0 feet of said Lot 25; thence West parallel with the North line of said Lot 25, 596.5 feet to the point of beginning, together with portions of Tyler Road, Kellogg Drive and Irving Avenue described as beginning at a point 50 feet east of the N.W. Corner of said Lot 25; thence S04°33'25"W, 46.28 feet; thence N01°38'45"W, 297.07 feet; thence N31°24'09"E, 58.72 feet; thence N64°17'13"E, 334.30 feet; thence S71°51'24"E, 28.84 feet; thence S28°00'00"E, 88.63 feet; thence S88°00'56"W, 8.56 feet; thence S01°15'56"E, 4.94 feet; thence S87°59'00"W, 150.19 feet; thence S64°17'13"W, 153.48 feet; thence S01°39'08"E, 38.31 feet; thence S64°21'10"W, 43.60 feet; thence S01°38'45"E, 98.08 feet; thence S88°34'21"W, 60.00 feet; thence S01°38'45"E, 124.98 feet to the place of beginning.

All Public easements and dedications being vacated by virtue of K.S.A. 12-512b.
Savoy Company, P.A.

Date _____ Surveyor
Mark A. Savoy RLS #788

Know all men by these presents that We, the undersigned, have caused the land described in the surveyors certificate to be platted into a Lot and a Block to be known as "KIA ADDITION", Wichita, Sedgwick County, Kansas. The utility easement is hereby granted for the construction and maintenance of all public utilities. The Storm Sewer easement is hereby granted as indicated for the construction and maintenance of a storm sewer. The Sanitary Sewer easement is hereby granted as indicated for the construction and maintenance of a sanitary sewer. A drainage plan has been developed for this plat and all drainage easements, rights-of-way, or reserves shall remain at established grades, or as modified with the approval of the City Engineer, and unobstructed to allow for the conveyance of stormwater. Access Control is hereby granted as shown on face of the Plat.

Kolbee Enterprises, Inc.

Leslie A. Eck President

State of Kansas) SS
Sedgwick County) The foregoing instrument acknowledged before me, this _____ day of _____, 2012, by Leslie A. Eck, President of Kolbee Enterprises, Inc. on behalf of the corporation.

Notary Public
My App't. Exp. _____

This plat of "KIA ADDITION", Wichita, Sedgwick County, Kansas, has been submitted to and approved by the Wichita Sedgwick County Metropolitan Area Planning Commission, Wichita, Kansas.

Dated this _____ day of _____, 2012.
Wichita-Sedgwick County Metropolitan Area Planning Commission

Shawn Farney Chair

John L. Schlegel Secretary

This plat approved and all dedications shown hereon, accepted by the City Council of the City of Wichita, Kansas, this _____ day of _____, 2012.

Carl Brewer Mayor

Karen Sublett City Clerk

Reviewed in accordance with K.S.A. 58-2005 on this _____ day of _____, 2012.

Tricia L. Robello, LS #1246 Deputy County Surveyor
Sedgwick County Kansas

Entered on transfer record this _____ day of _____, 2012.

Kelly B. Arnold County Clerk

State of Kansas) SS
Sedgwick County)

This is to certify that this plat has been filed for record in the office of the Register of Deeds, this _____ day of _____, 2012, at o'clock _____M: and is duly recorded.

Bill Meek Register of Deeds

Tanya Buckingham Deputy

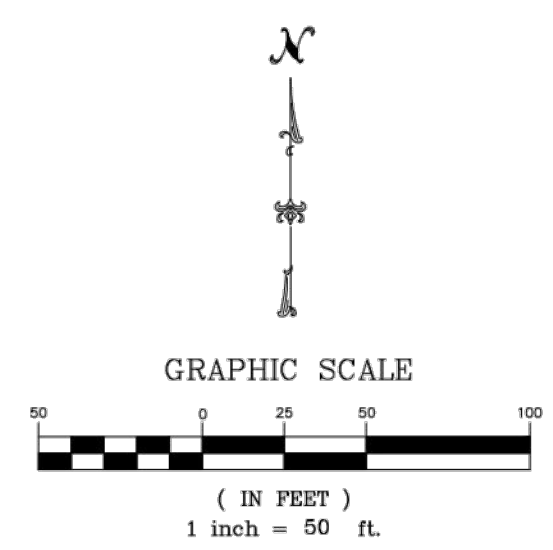

- LEGEND:
- P = Platted
 - M = Measured
 - C = Calculated
 - D = Described
 - 1/2" IP 1/2" IRON PIPE (FOUND)
 - 1/2" R 1/2" REBAR (FOUND)
 - 4M 1/2" REBAR W/ARMSTRONG CAP (FOUND)
 - PEC 1/2" REBAR W/PEC CAP (FOUND)
 - TFS 1/2" REBAR W/TERRA-TECH CAP (FOUND)
 - RAB 1/2" REBAR W/RAB CAP (FOUND)
 - SAV(F) 1/2" REBAR W/SAVOY CAP (FOUND)
 - MW 1/4" HOLE (FOUND)
 - W CHEELED V-NOTCH (FOUND)
 - TH CITY OF WICHITA CONTROL (FOUND)

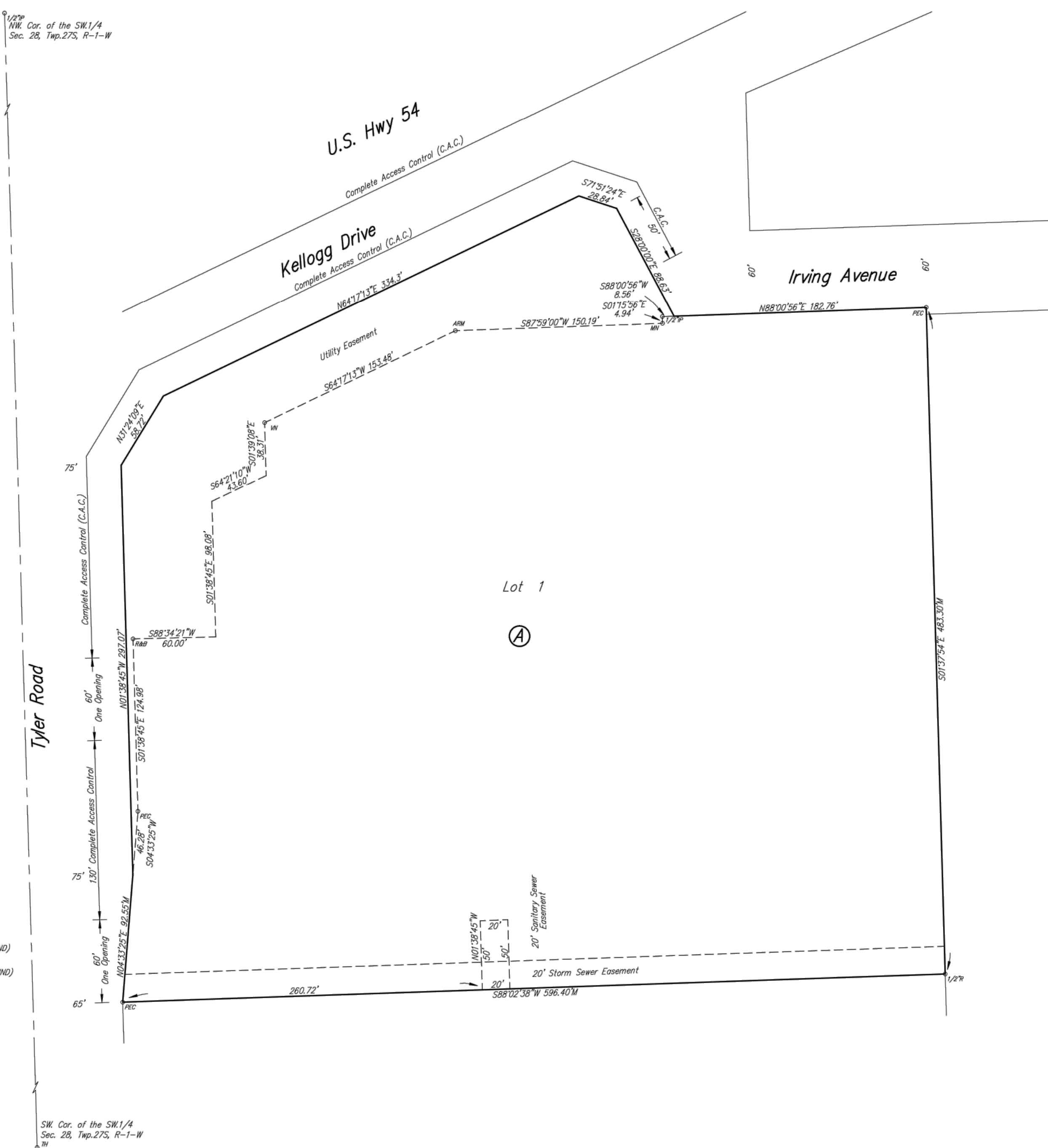

PROJECT NO. 12FF13024 S
Savoy Company, P.A.
Land Surveyors
438 S. Hydraulic, Wichita, KS 67211-1911
PH (316) 265-0005
FAX (316) 265-0275
www.savoyco.com

KIA ADDITION KELOGG & TYLER WATER DISTRIBUTION SYSTEM IMPROVEMENTS PLAT CITY OF WICHITA, KANSAS GARY JANZEN, P.E. - CITY ENGINEER C.O.M.# 1708 PFW O.C.A.# 607853	POE & ASSOCIATES, INC. CONSULTING ENGINEERS 5940 E. Central, Suite 200 • Wichita, KS 67208-4242 Phone 316-685-1111 • FAX 316-685-1444
Approved _____ By _____ Date _____ No. _____	11/20/12 PROFESSIONAL ENGINEER KANSAS
FINAL Engineer: S. SERVIS Designer: S. SERVIS Drawing: P: 102020\BassSWL.dwg Date: 12/14/2012	Sheet 11 of 11