

STATE	PROJECT NO.	YEAR	SHEET NO.	TOTAL SHEETS
KANSAS	472-84915	2013	16	83

GENERAL NOTES

The details depicted here may not be appropriate for all locations. Designs shall meet this criteria on all new construction projects unless impracticable by site restrictions. For an existing sidewalk facility where the sidewalk will be replaced, sidewalk will be replaced according to this drawing to the maximum extent feasible.

Provide ramps at all corners street intersections where there is an existing or proposed sidewalk and curb. Provide ramps at mid-block walk locations for hospitals, medical centers and athletic stadiums.

Details shown on this sheet apply to all construction or reconstruction of streets, curbs or sidewalks. See standard specifications for additional information.

Restrict use of sidewalk ramp Type 2 to locations where it is not feasible to use Types 1 or 3.

Curb cut ramps are to be located as shown on the plans or as directed by the Engineer.

Do not place drainage structures in line with ramps except where existing drainage structures are being utilized in the new construction. Ramp locations should take precedence over the location of drainage structures.

Ramp sidewalks where the driveway curb is extended across the walk. Construct ramp with uniform grade free of sags and short grade changes.

Place 3/4" redwood expansion joints flush with the surface at a maximum spacing of 125'. Place 3/4" redwood expansion joints at sidewalk junctions, see plan details. Where sidewalk abuts a curb place 3/4" redwood board expansion joint flush with the surface.

Place 1/2" premolded (Non-extruding, Type B) Joint filler where sidewalk is parallel and adjacent to a rigid surface.

Slope sidewalk toward the street at a 50:1 or flatter. Slope or depress sidewalk where necessary to fit alleys and entrances see plans or at Engineer's direction.

Where clear width of sidewalk between top of ramp and building or other obstruction is less than 48 inches, slope the flared sides 12:1 or flatter.

Sidewalk shown to be constructed in back of an entrance shall be placed 6" thick with welded wire mesh reinforcement. Gauge and spacing of wires are the same as entrance pavement (See Reinforcement Diagram). Bid item will be "Sidewalk Construction (6") either with or without air entrainment.

Contractor may opt to use Concrete Grade 3.0 (AE) throughout for construction of steps, but all work and materials are paid for under the bid item "Grade 3.0 Conc. (Misc.)."

Surface texture ramp slope with a wooden float or brushed finish.

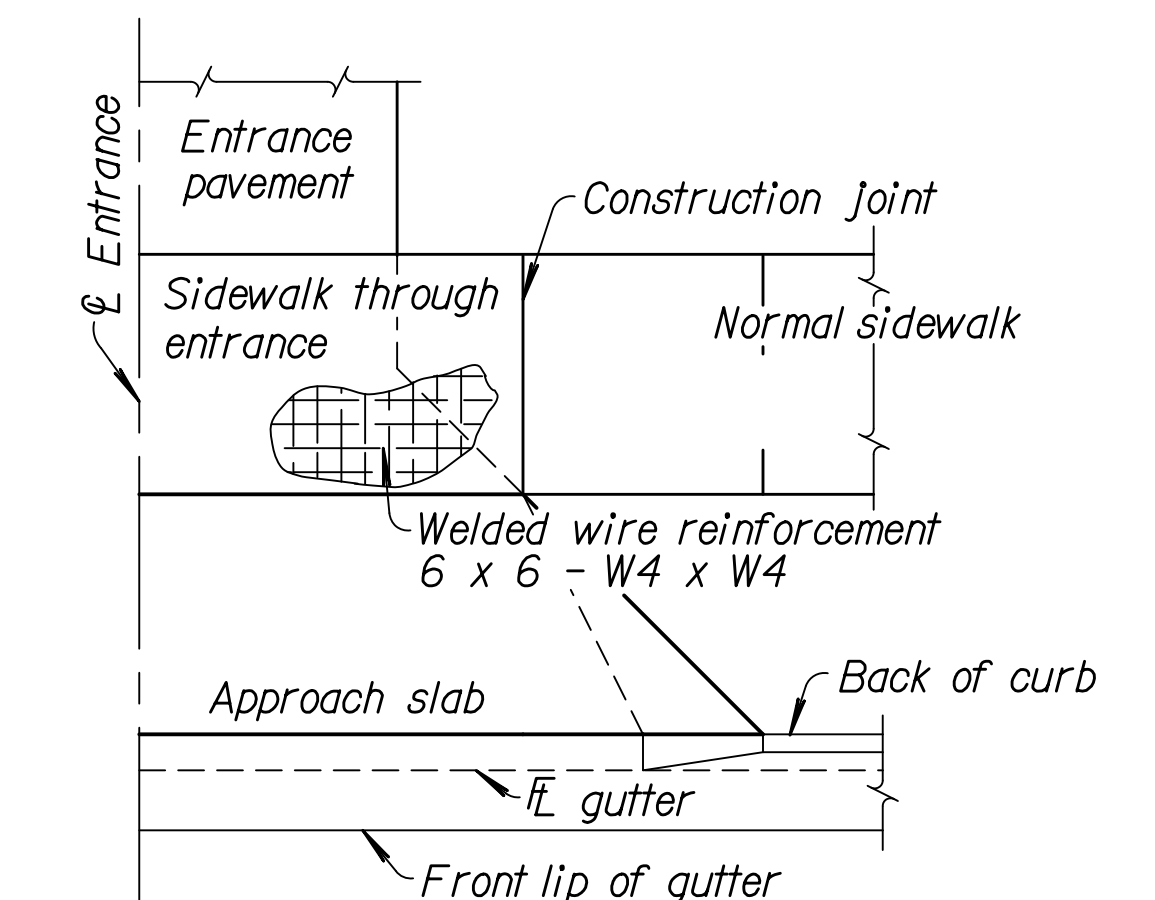

REINFORCEMENT DIAGRAM
SIDEWALK THROUGH ENTRANCE

See standard drawing RD726 for details of Alley and Entrance Pavement.

LEGEND

- Sidewalk Ramp Type 1
- Sidewalk Ramp Type 2
- Sidewalk Ramp Type 3
- Preferred location of drainage inlet (Typical)
- Alternate location of drainage inlet (Typical)
- Sidewalk

NO.	DATE	REVISIONS	BY	APP'D
11	10-17-11	Revised General Note		S.W.K. J.O.B.
10	5-23-11	Revised notes		S.W.K. J.O.B.
9	2-10-10	Revised notes & General Note		S.W.K. J.O.B.
8	7-30-08	Reorg. layout, added steps sheet		S.W.K. J.O.B.

KANSAS DEPARTMENT OF TRANSPORTATION

SIDEWALK & STEPS

RD725	DESIGNED	12-5-11	APP'D.	James O. Brewer
	DETAIL CK.		QUANTITIES	TRACED
	DESIGN CK.		QUAN. CK.	TRACE CK. King

SECTION J-J see standard drawing RD725B for details of Steps and Handrail.

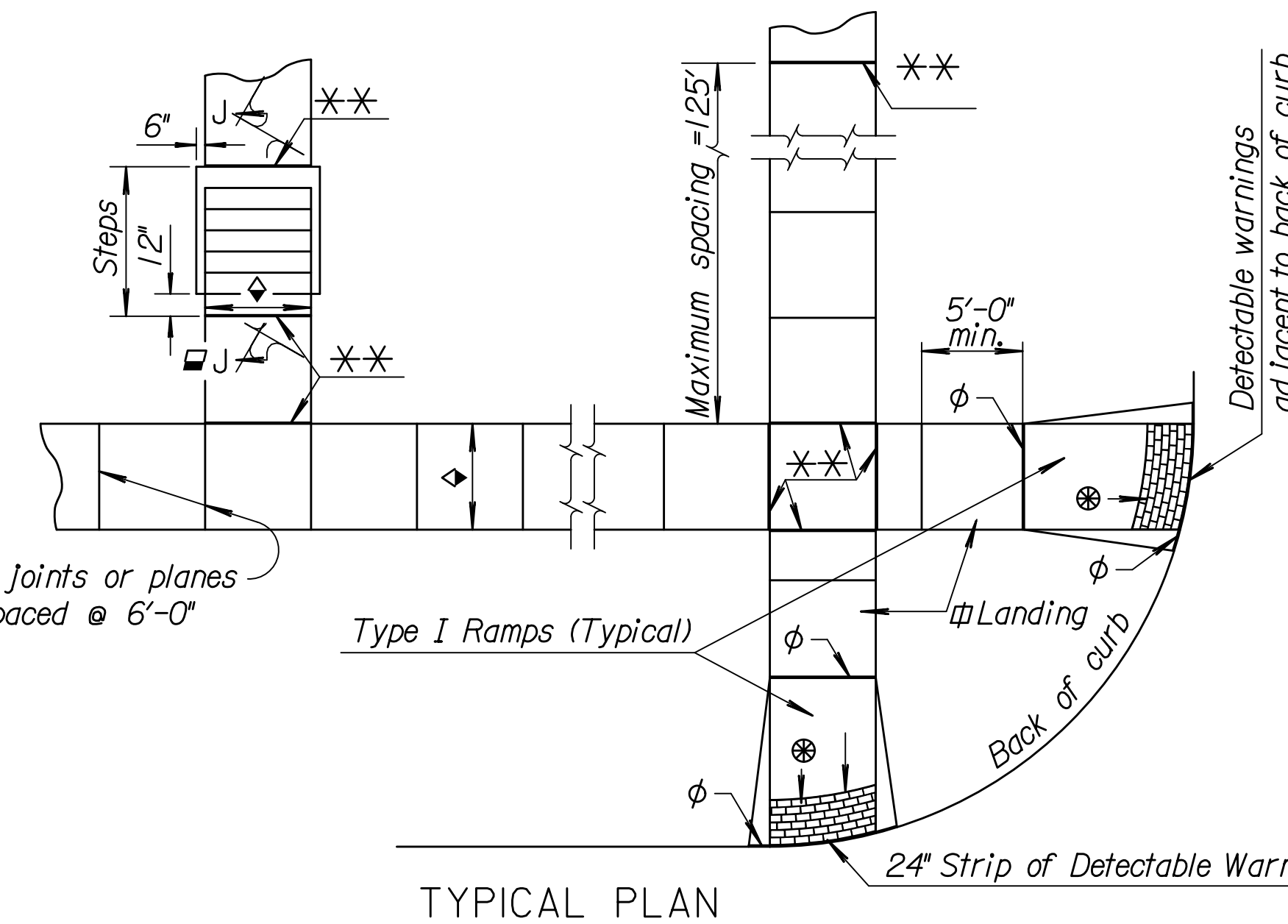

Construction joints or planes of weakness spaced @ 6'-0" ctrs. or less.

16d Galvanized nail driven half way thru (24 hr. water soaked board)
For other than 5'-0" (width) use 6" from the end and balanced (3'-0" max.) nail spacing.

Expansion Joint (3/4" Redwood board) placed at either back of curb line or at sidewalk back of curb line or at sidewalk line.

Expansion Joint (3/4" redwood board) located as shown.

Variable width (5'-0" min.). Entrance walk to be same width as approach walk. Use sidewalk width of 4'-0" where existing conditions prohibit use of 5'-0".

New construction ramp slopes are 12:1 or flatter. Desirable ramp slopes for existing sites are 12:1 or flatter. Where space limitations prohibit construction of a 12:1 slope on existing sites, use the following slopes:
8:1 or flatter for a maximum rise of 3 inches
10:1 or flatter for a maximum rise of 6 inches

Use a landing slope of 50:1 or flatter. Landings are the same width as ramp and a minimum 5'-0" in length.

Use a counter slope of 20:1 or flatter at the base of sidewalk ramps. Refer to standard drawing RD725A for additional curb and gutter details.

Detectable warning installation is typical and required on Sidewalk Ramps Type 1, Type 2, Type 3, median ramp crossings and other locations as shown in the plans. See standard drawing RD725A for additional details.

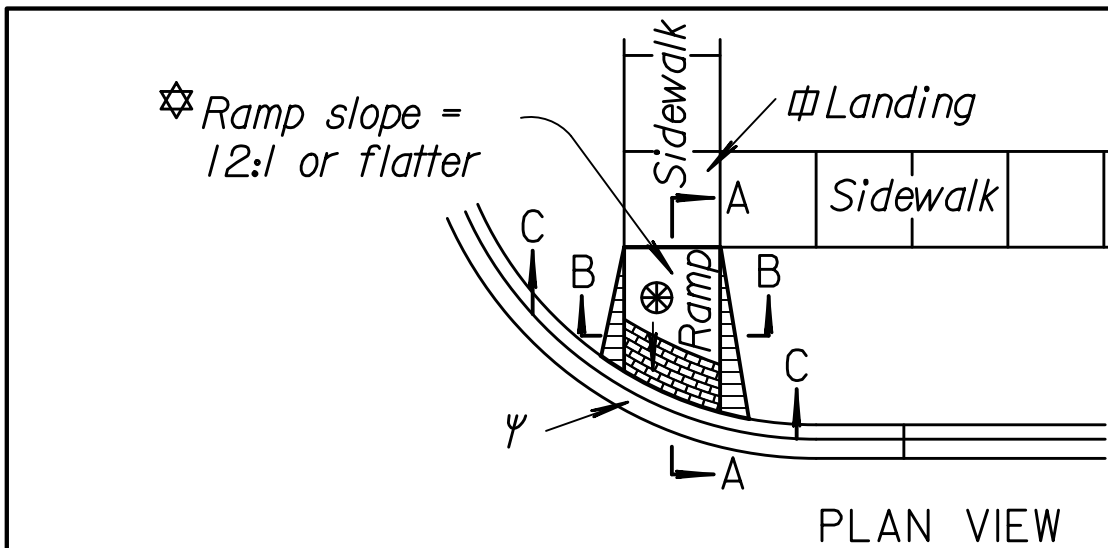

PLAN VIEW

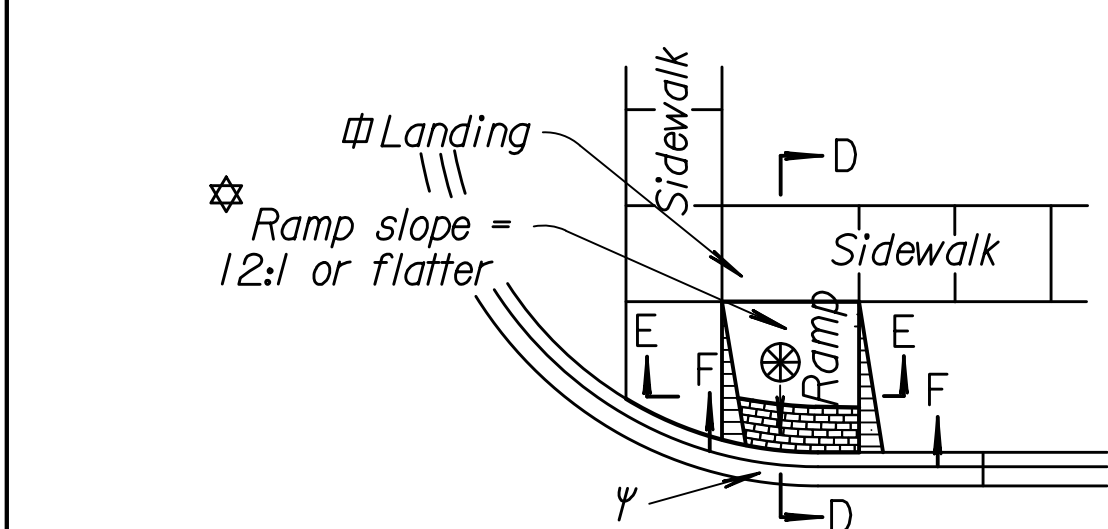
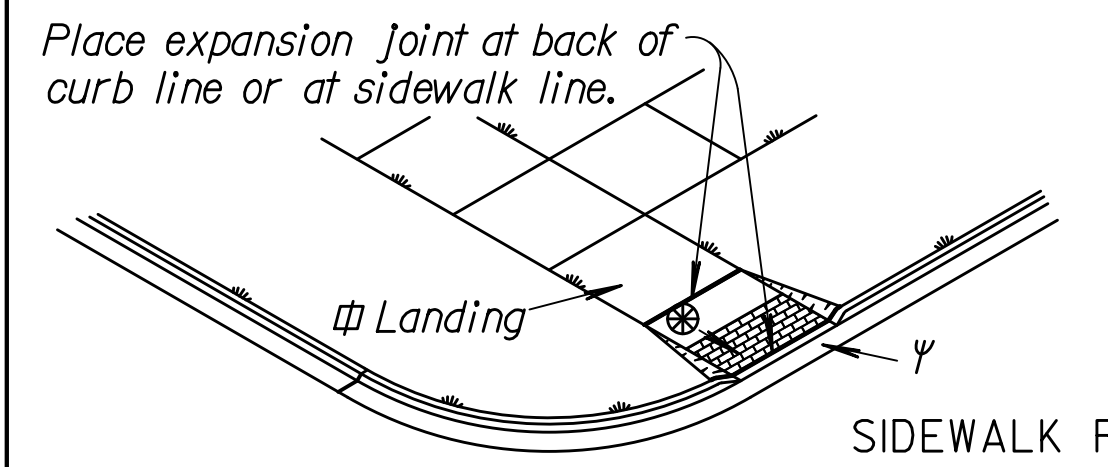

PLAN VIEW

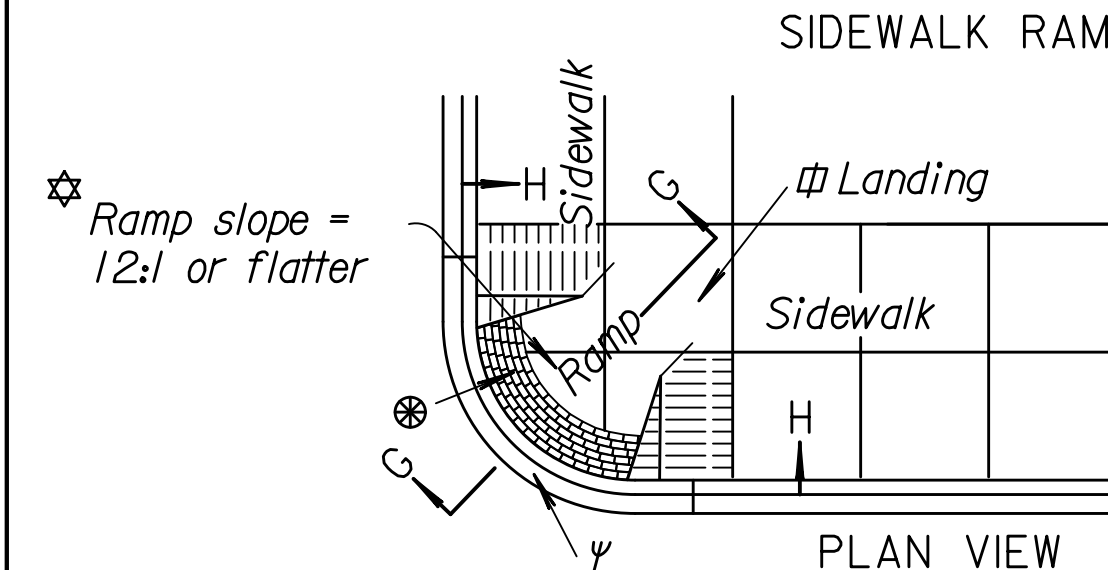
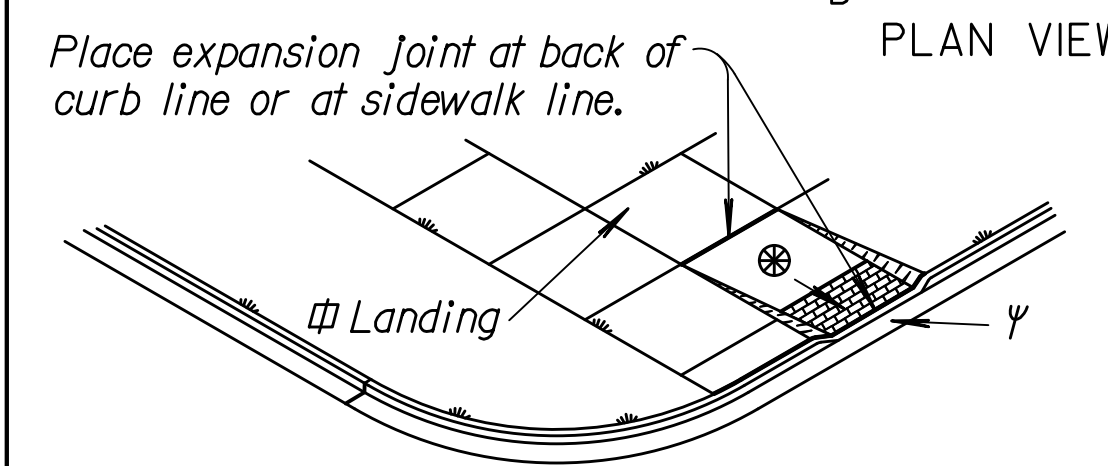

PLAN VIEW

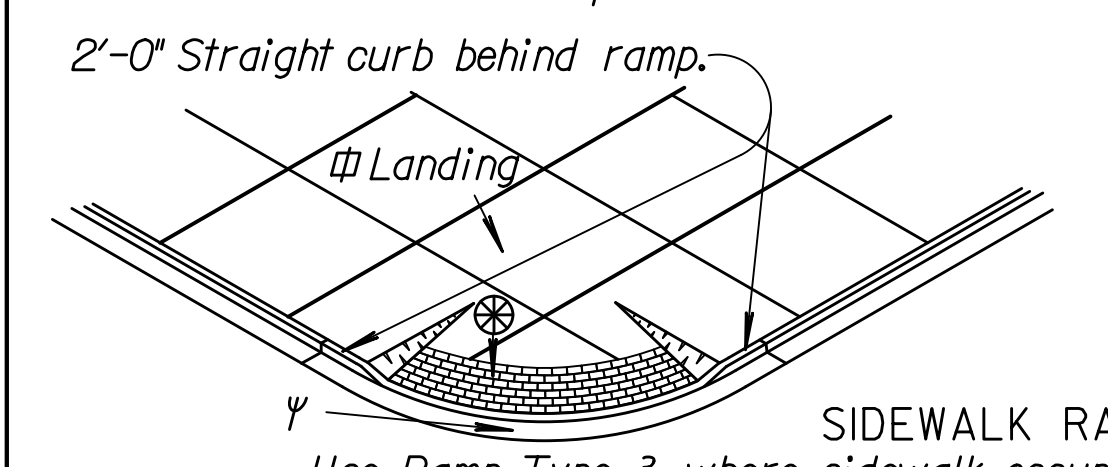

PLAN VIEW

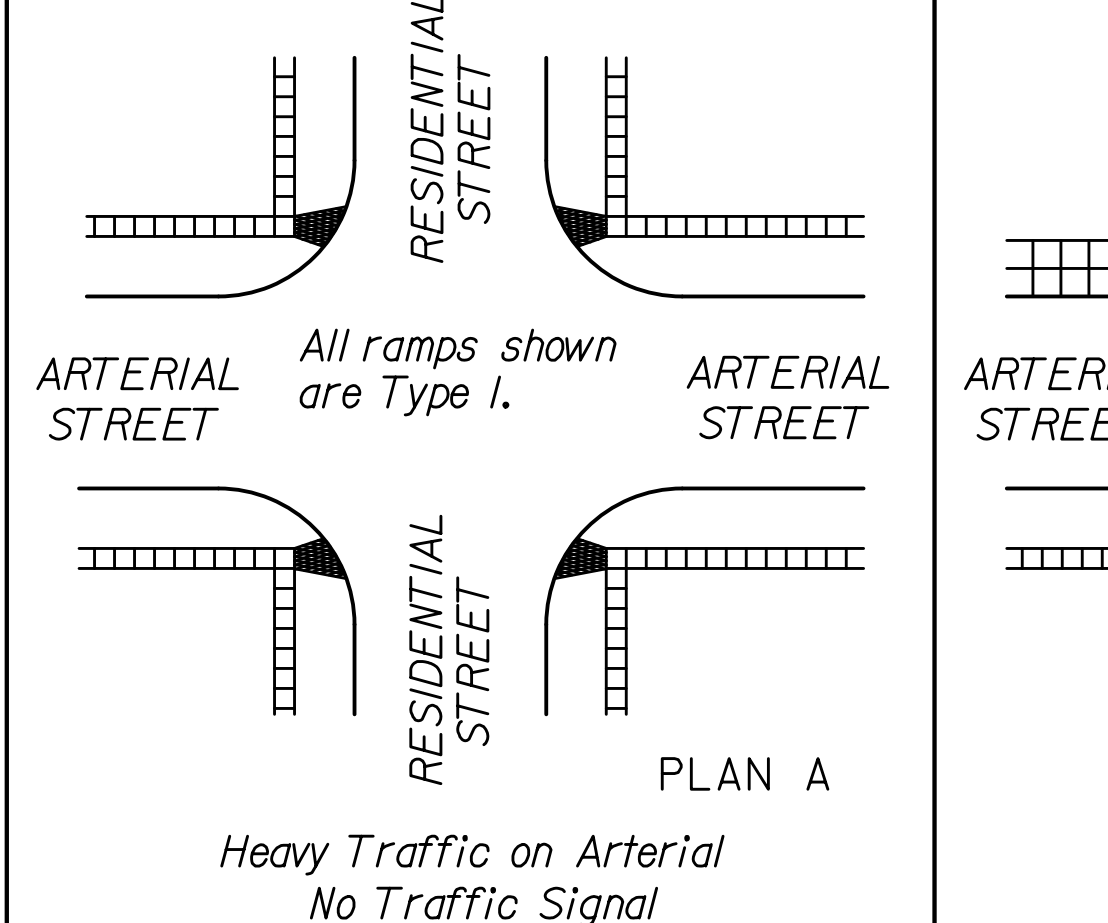

PLAN A

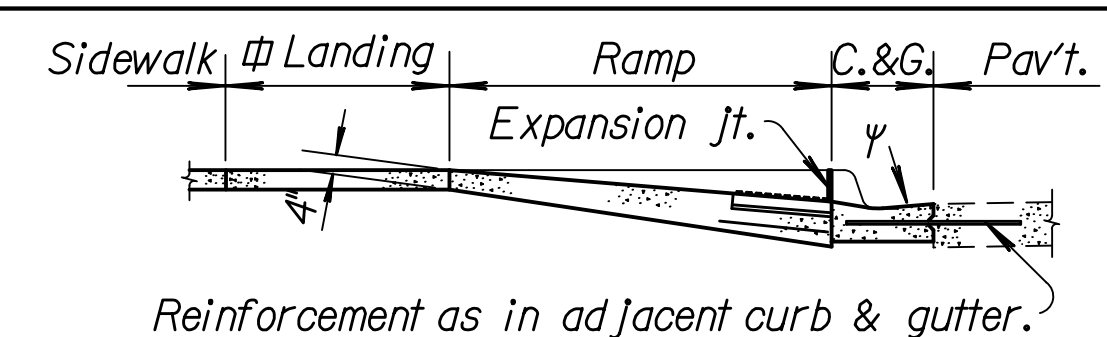

SECTION A-A

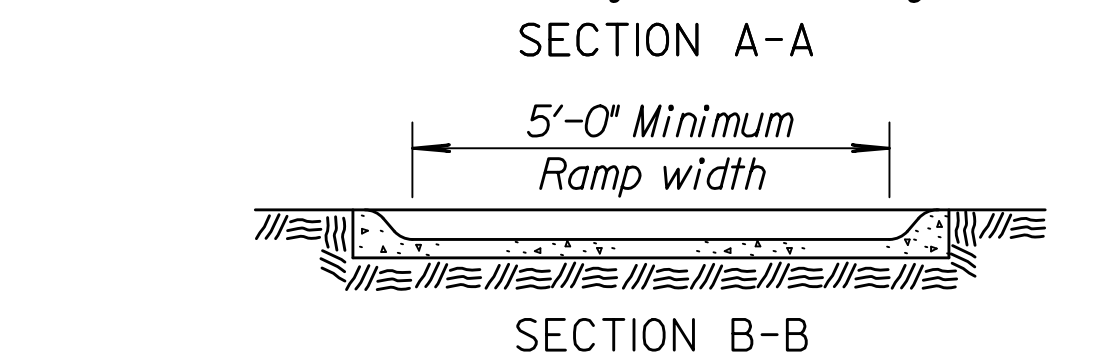

SECTION B-B

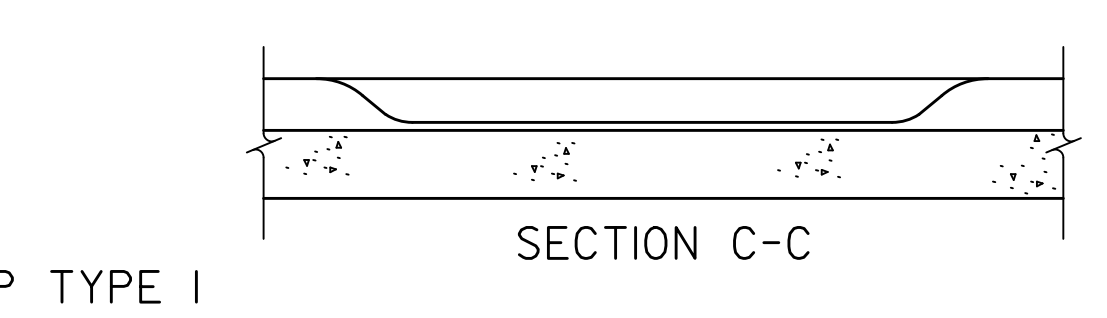

SECTION C-C

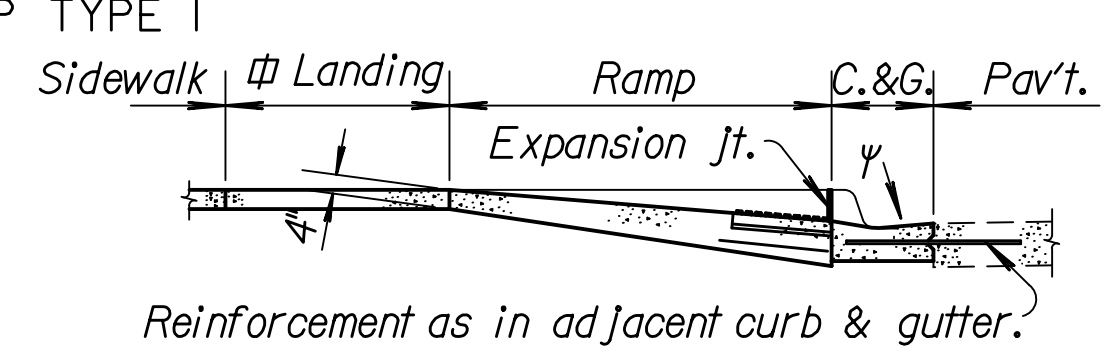

SECTION D-D

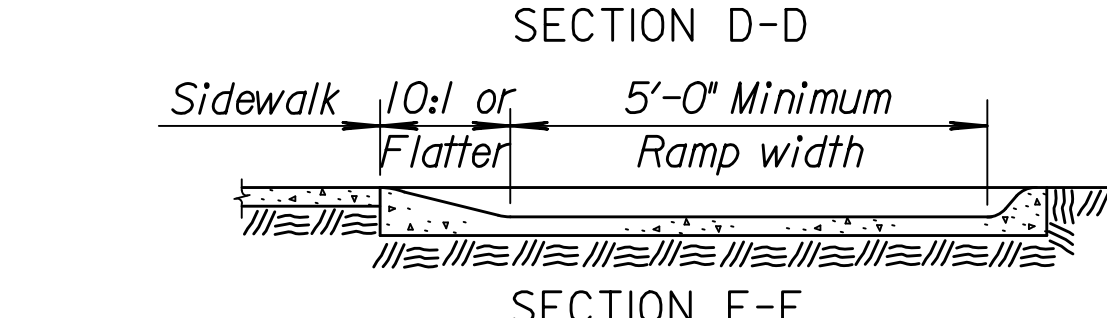

SECTION E-E

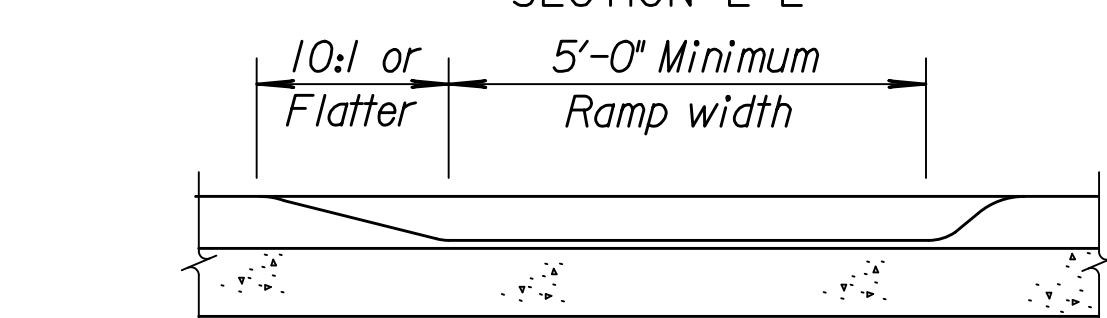

SECTION F-F

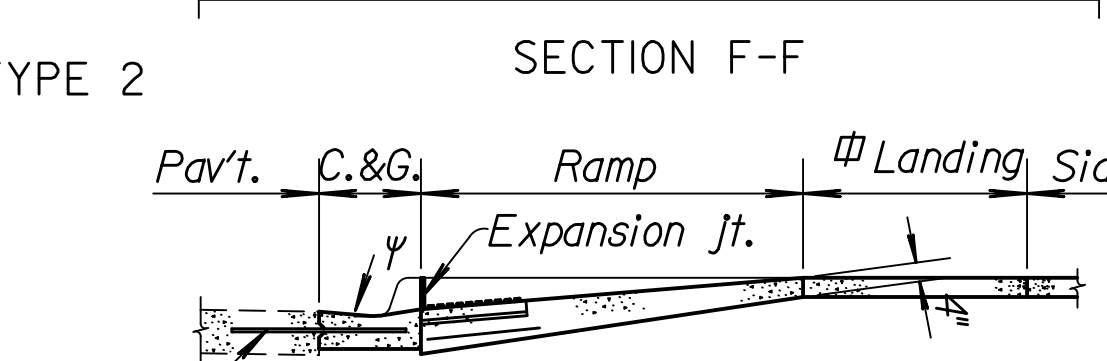

SECTION G-G

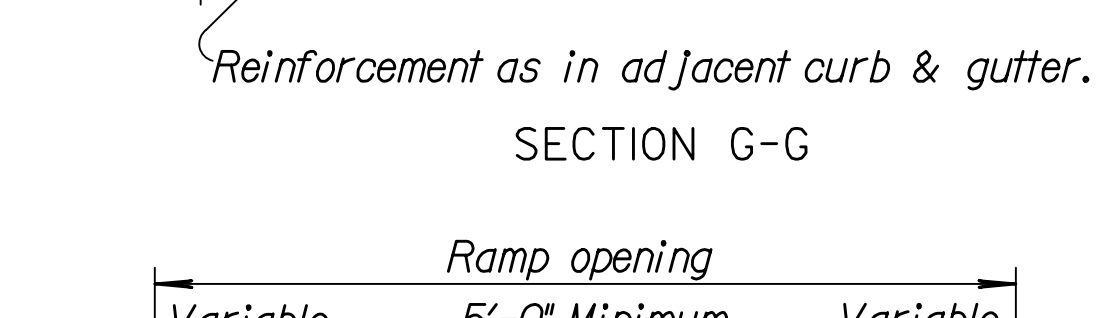

SECTION H-H

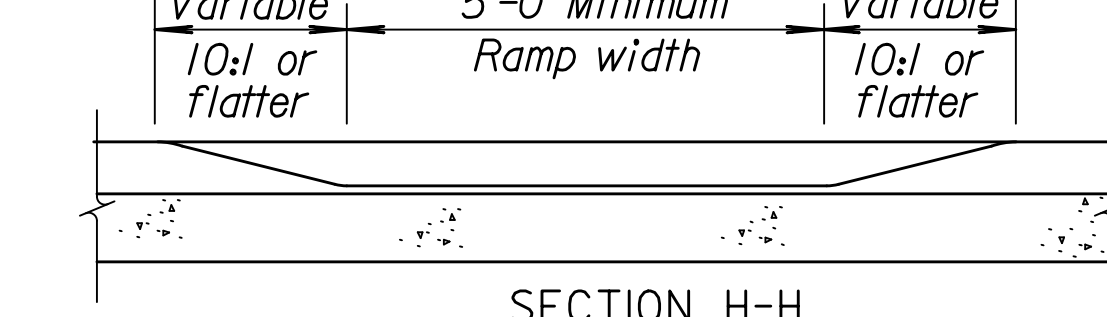

SECTION H-H

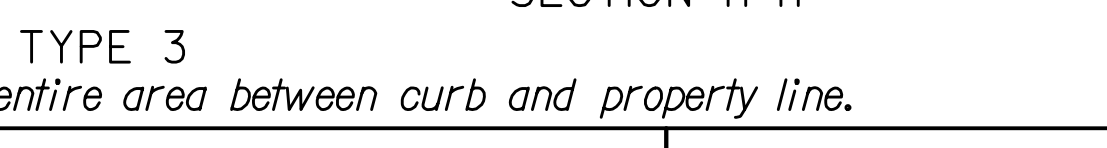

SECTION H-H

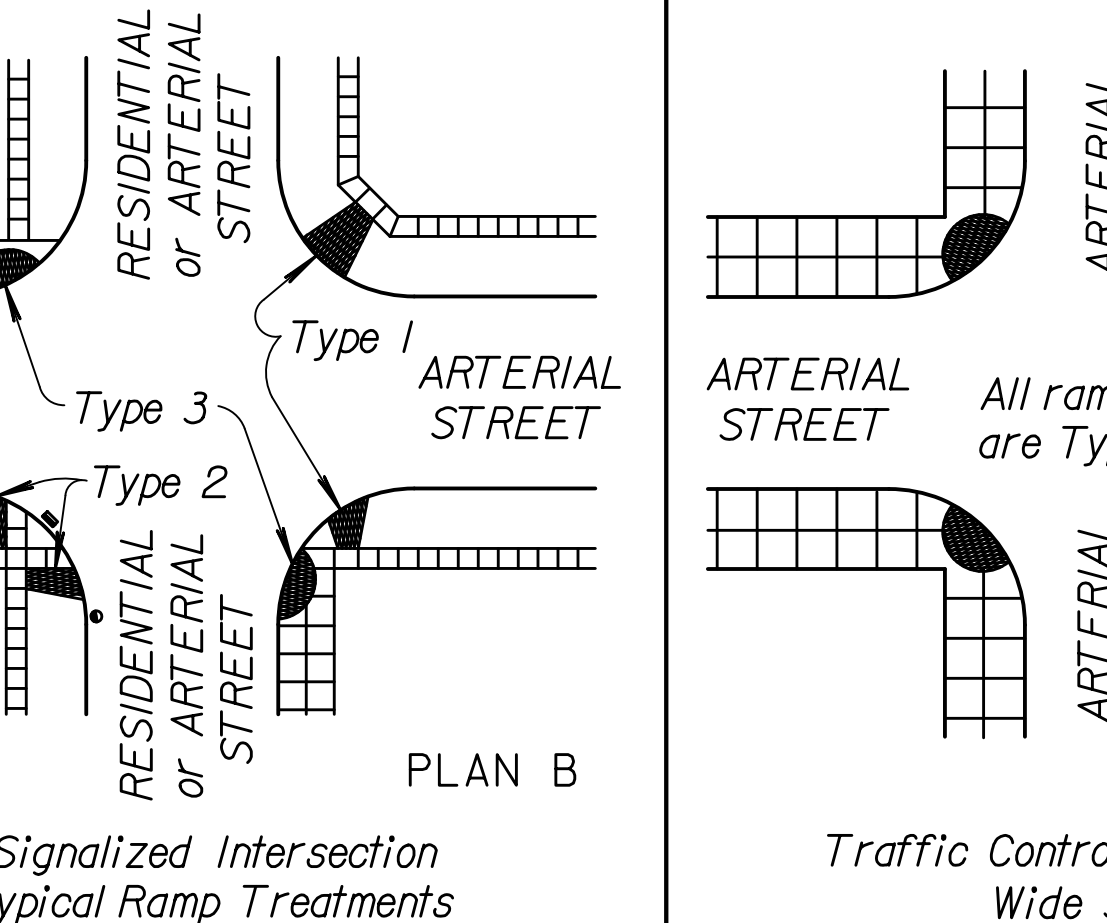

PLAN B

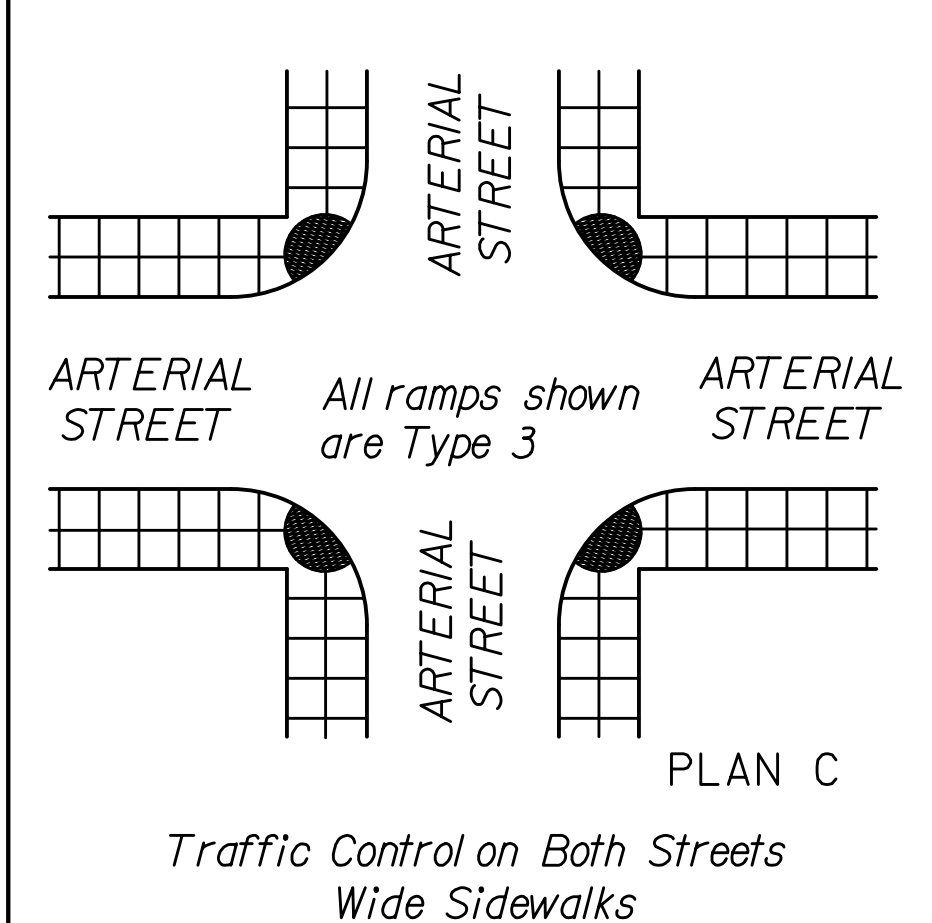

PLAN C

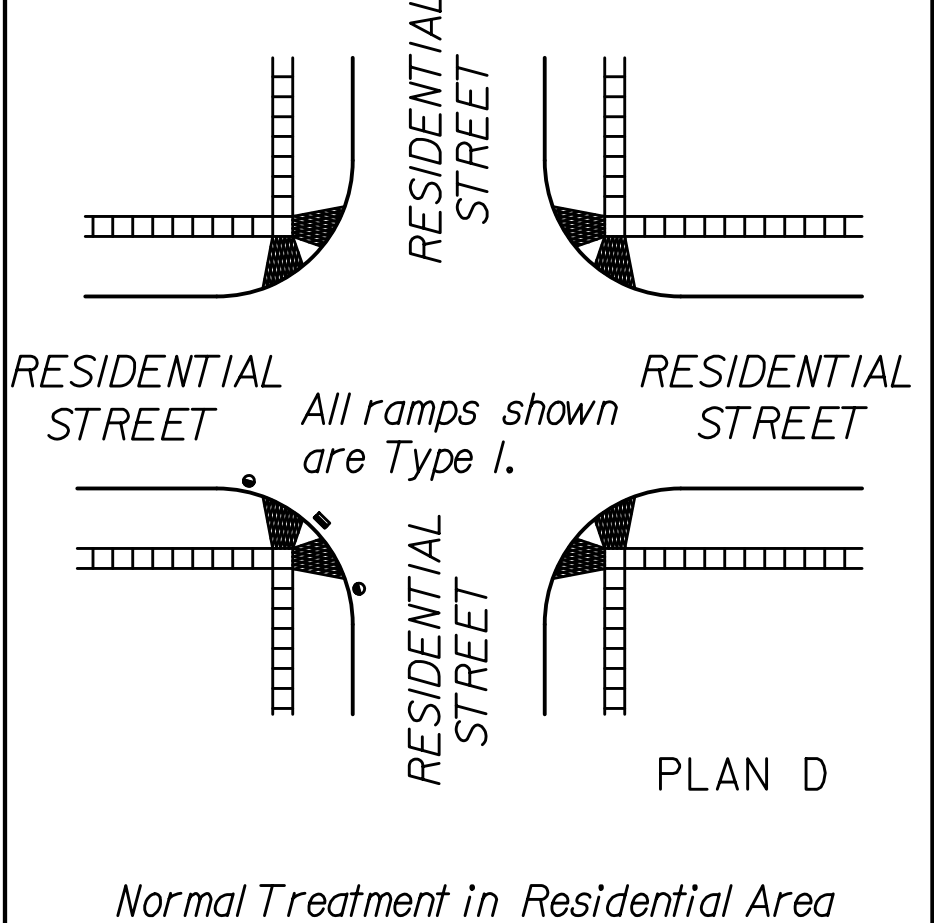

PLAN D

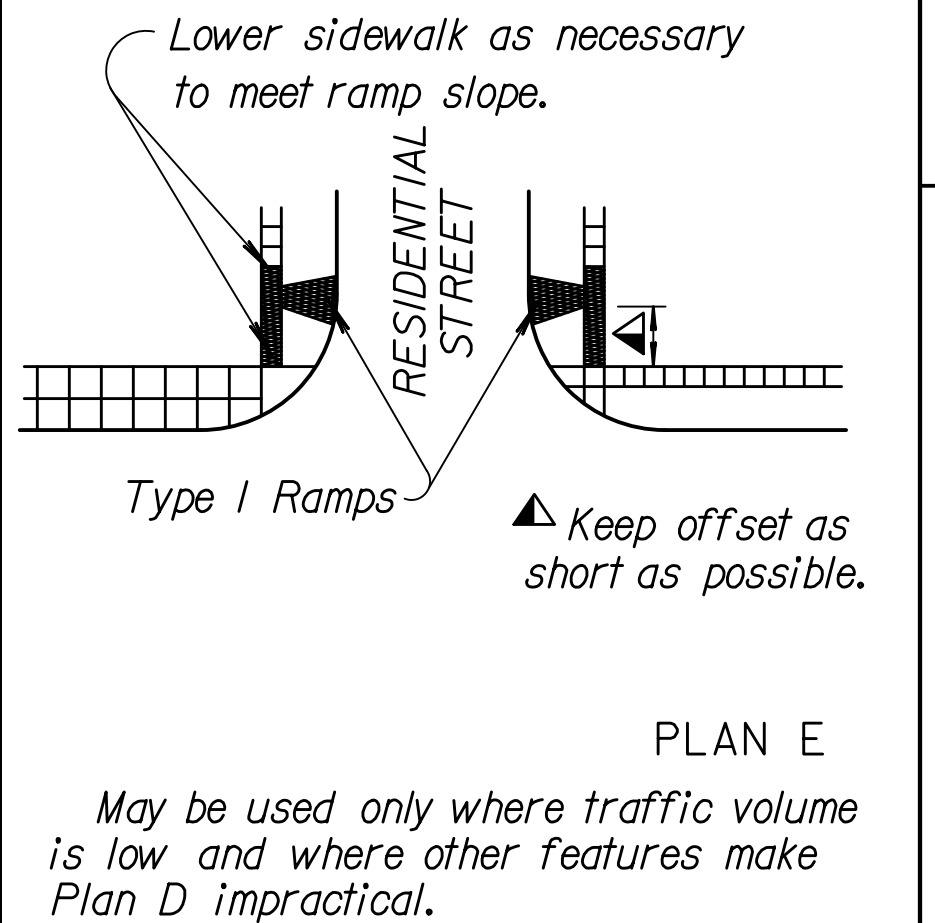

PLAN E

May be used only where traffic volume is low and where other features make Plan D impractical.

Drawn By: svb
Plotted: 5/16/2013
File: I:\2010\Standards\10281-rd725.dgn