

STATE	PROJECT NO.	YEAR	SHEET NO.	TOTAL SHEETS
KANSAS	472-85066	2014	169	388

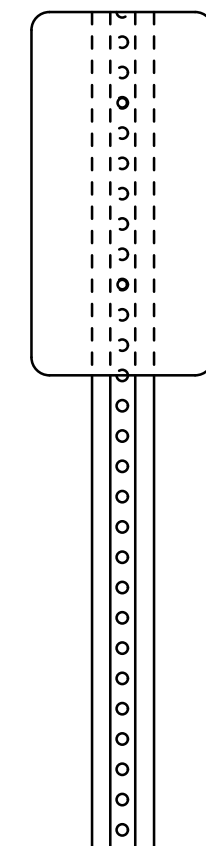

### TYPE 2 OBJECT MARKER ASSEMBLY POSITIONS

FLAT SHEET OBJECT MARKERS:  
SEE FLAT SHEET SIGN BLANK DETAIL SHEETS  
FOR THE ALUMINUM ALLOYS AND THICKNESS.

THE 6" X 12" OBJECT MARKER SIGN FACES  
SHALL BE COVERED WITH TYPE IV HIGH INTENSITY  
YELLOW RETROREFLECTIVE SHEETING.

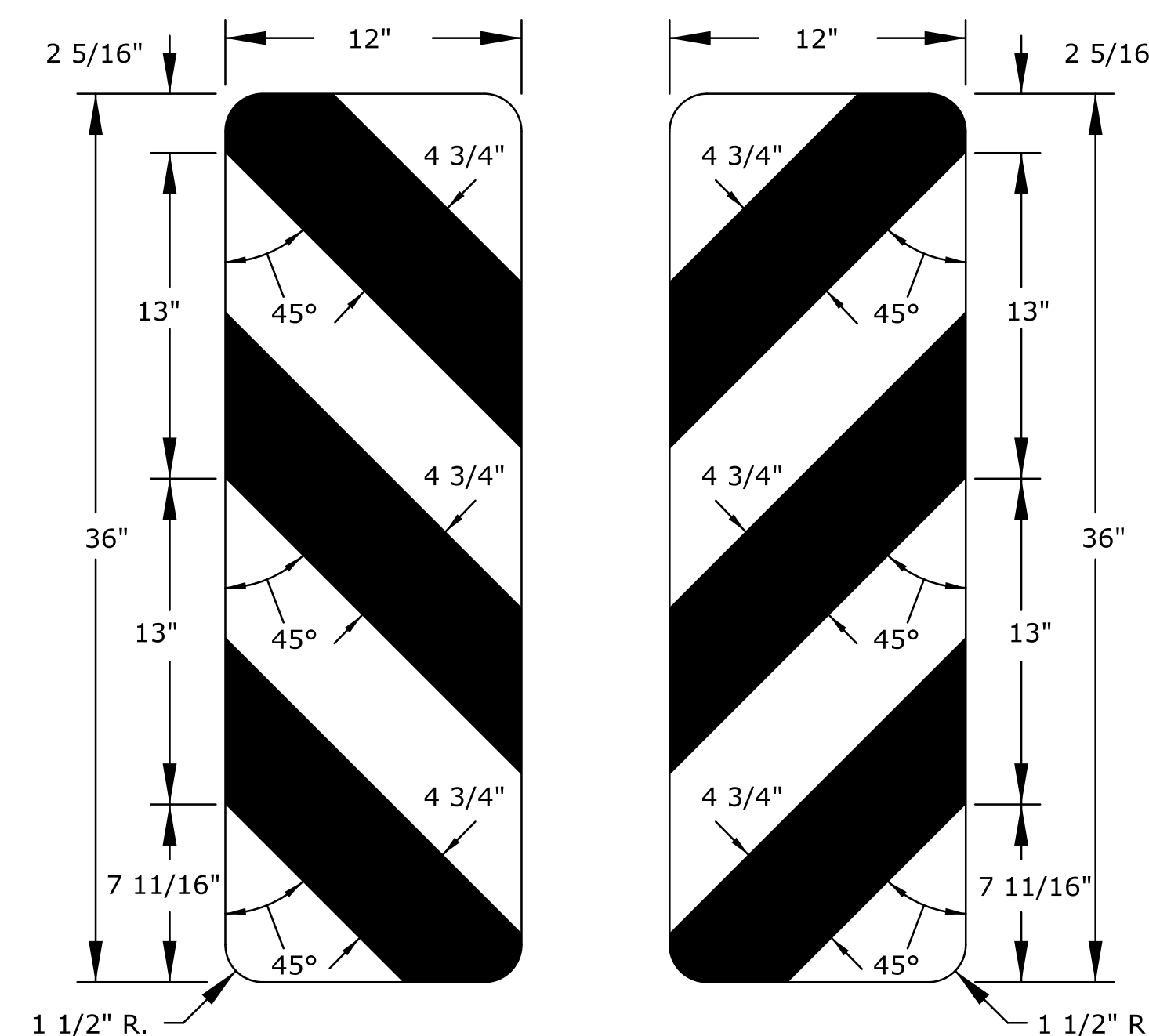

T3/OM-L

T3/OM-R

COLORS:

- YELLOW (RETROREFLECTIVE)
- BLACK (NON-REFLECTIVE)

FLAT SHEET OBJECT MARKERS:  
SEE FLAT SHEET SIGN BLANK DETAIL SHEETS  
FOR THE ALUMINUM ALLOYS AND THICKNESS.

THE OBJECT MARKER SIGN FACE SHALL BE  
COVERED WITH TYPE IV HIGH INTENSITY YELLOW  
RETROREFLECTIVE SHEETING.

### DETAILS FOR ATTACHING OBJECT MARKERS TO STEEL 'U' POSTS

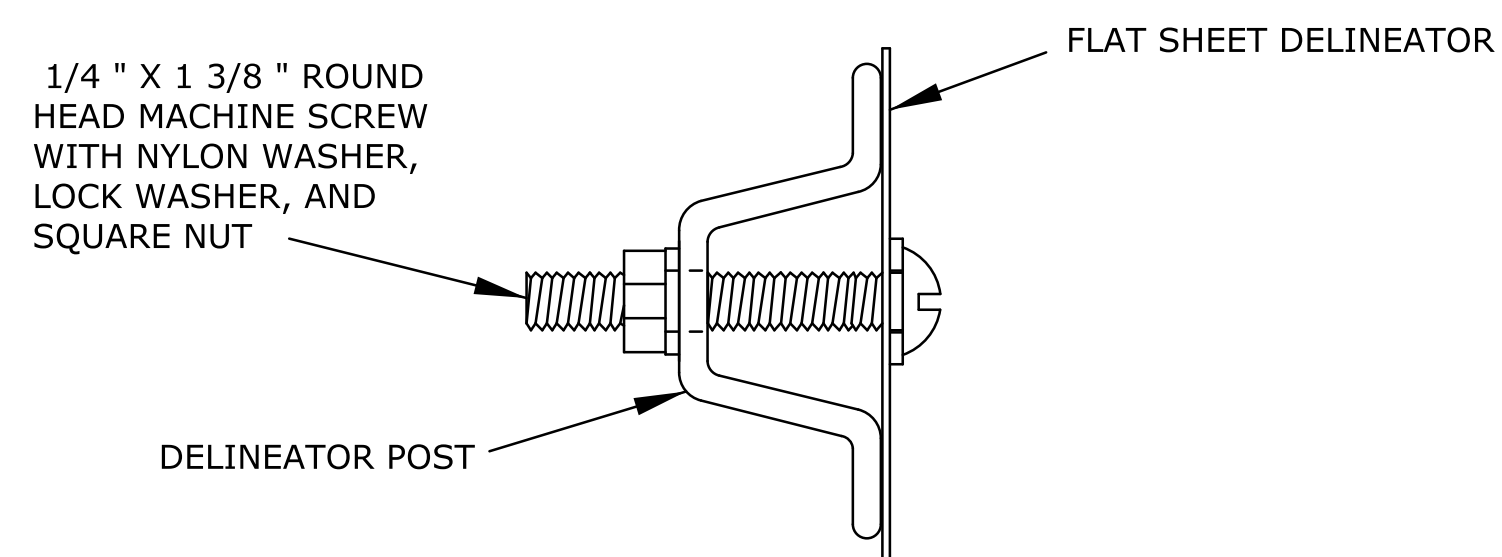

FLAT SHEET DELINEATOR MOUNTING

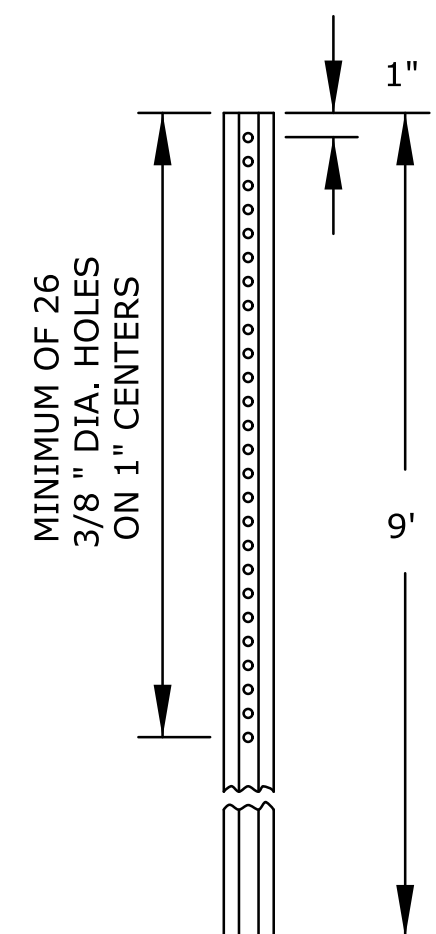

PUNCHING DETAILS

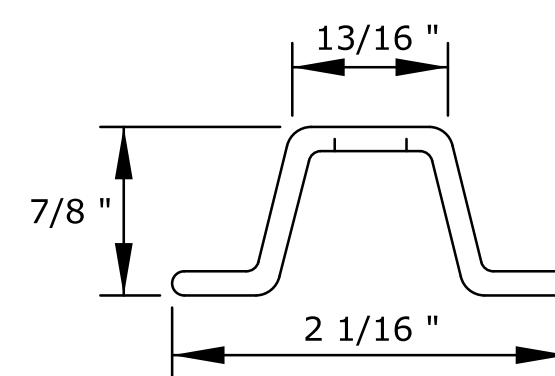

POST DIMENSIONS  
(ALL DIMENSIONS SHOWN ARE NOMINAL)

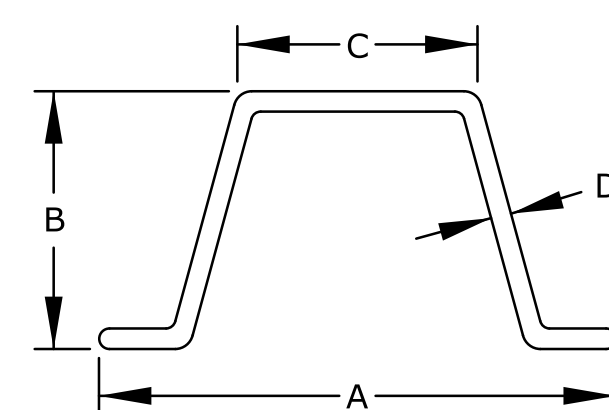

DIM.	2 LB/FT
A	3 1/8
B	1 17/32
C	1 1/4
D	1/8

(DIMENSIONS ARE NOMINAL)

### 2LB. 'U' POST DETAILS

5/16" X 2 1/4" CARRIAGE  
BOLT WITH LIGHT LOCK WASHER  
AND REG. SF HEX NUT

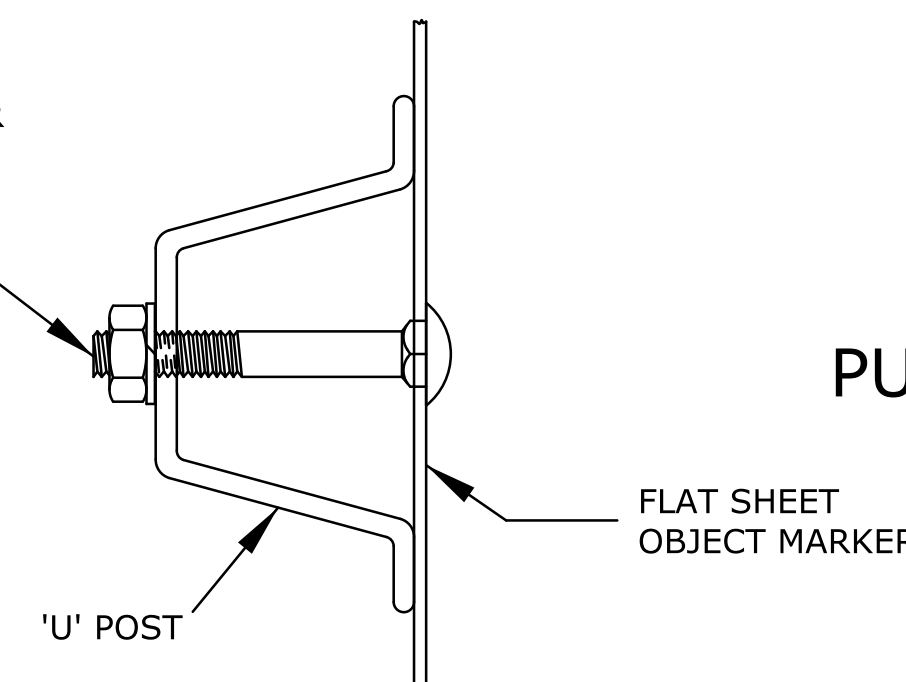

### 'U' POST MOUNTING DETAILS

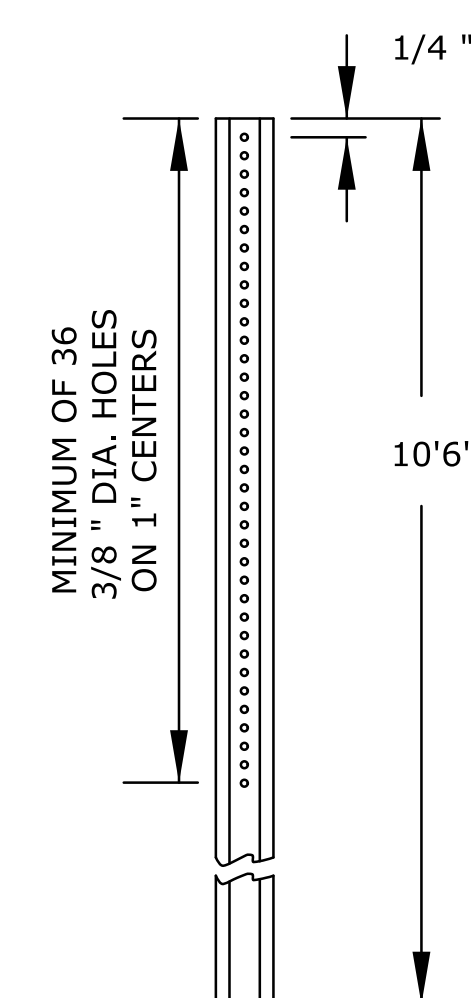

'U' POST  
PUNCHING DETAILS

ALL DIMENSIONS ARE IN INCHES  
UNLESS OTHERWISE NOTED.

NO.	DATE	REVISIONS	BY	APP'D
1	7/23/10	Changed Sheetting Type	D.D.G.	D.B.

KANSAS DEPARTMENT OF TRANSPORTATION  
DESIGN DETAILS  
FOR OBJECT MARKERS  
TYPE 2 AND TYPE 3

TE415 7/1/03

FHWA APPROVAL	7/23/2010	APP'D	Steven A. Buckley
DESIGNED	D.D.G.	DETAILED	W.S.B.
DESIGN CK.	S.A.B.	DETAIL CK.	D.D.G.
		QUANTITIES	TRACED
		QUAN. CK.	TRACE CK.