

SHOULDER SECTION

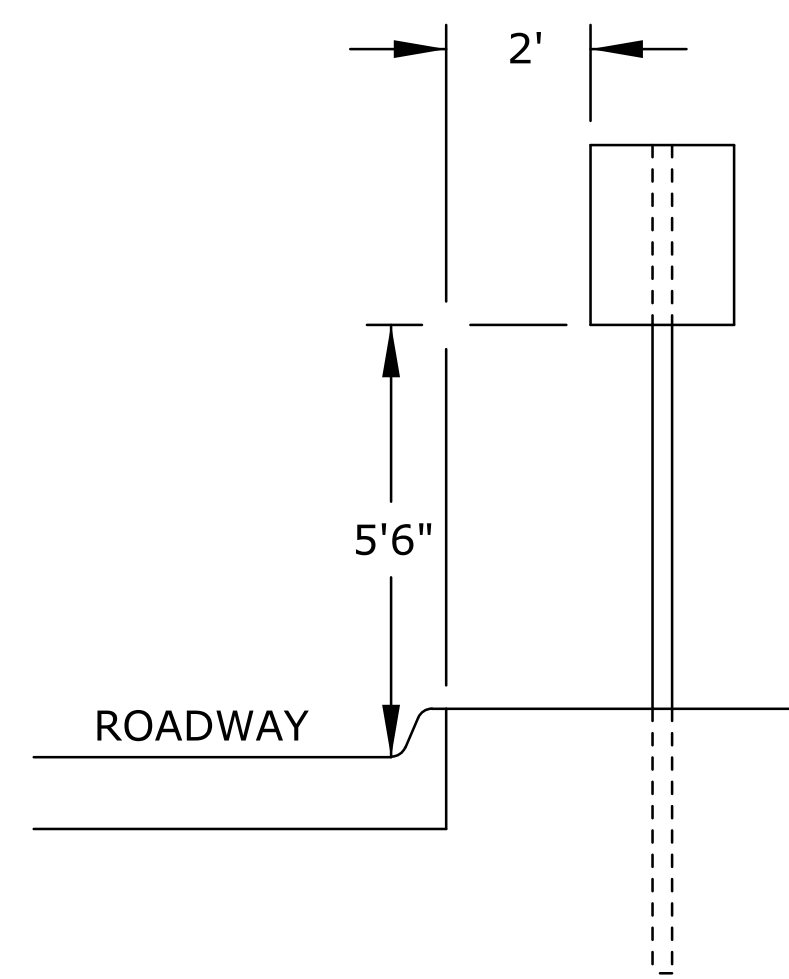

CURB SECTION

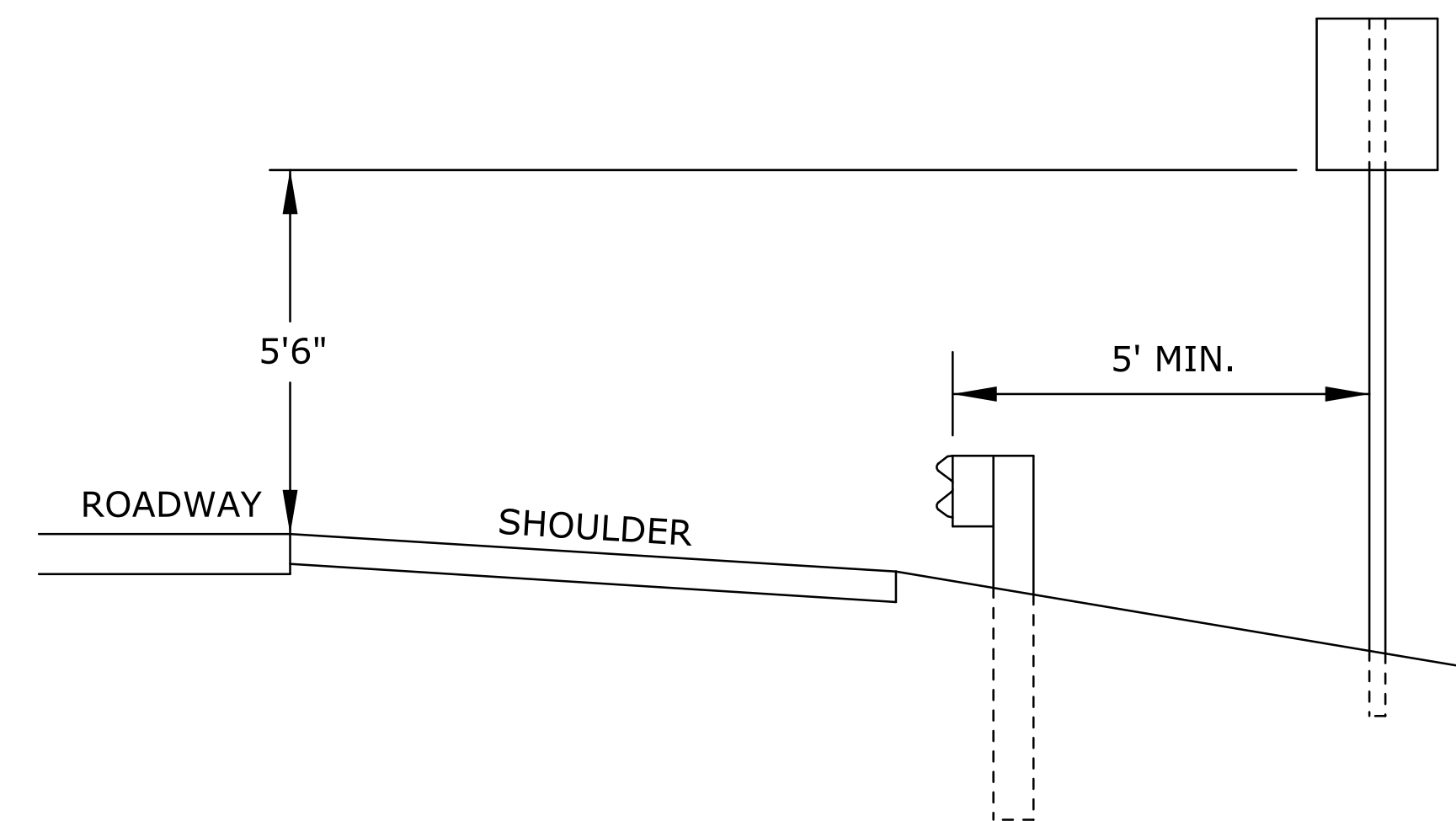

GUARD FENCE SECTION

LATERAL POSITIONING OF CHEVRON (W1-8 SIGN)

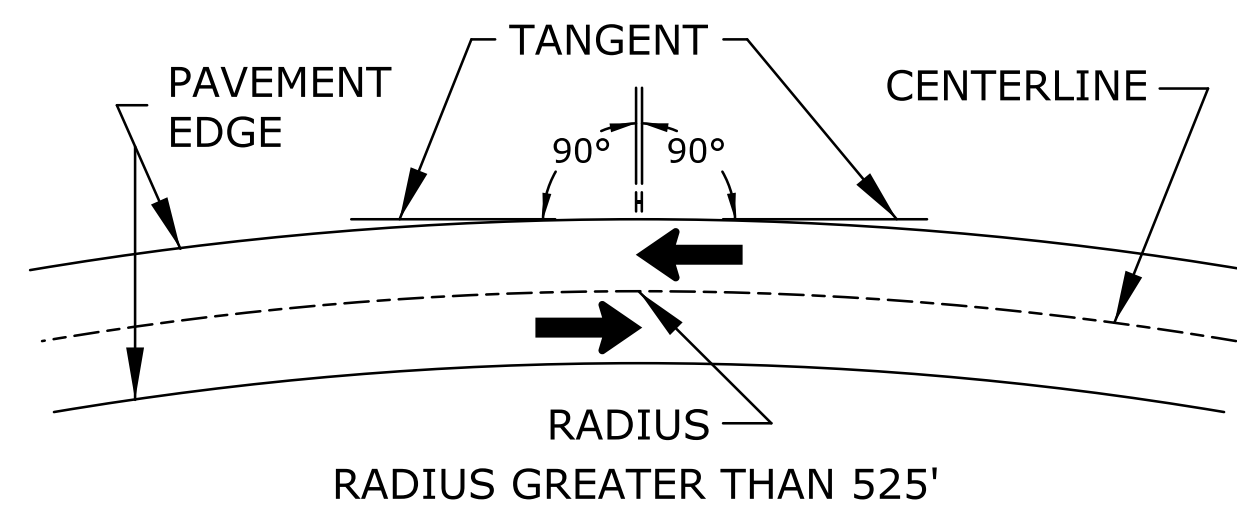

RADIUS GREATER THAN 525'

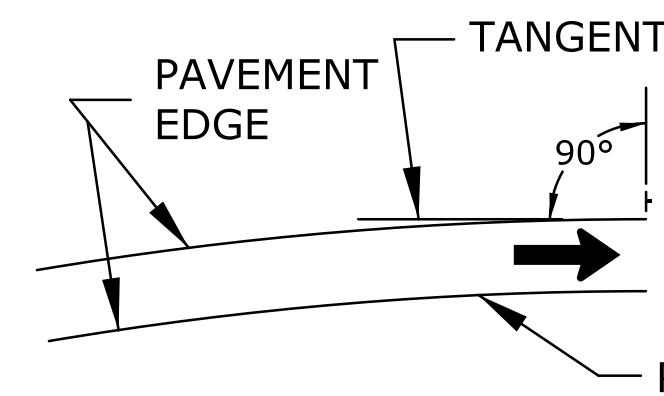

RADIUS GREATER THAN 500 FT

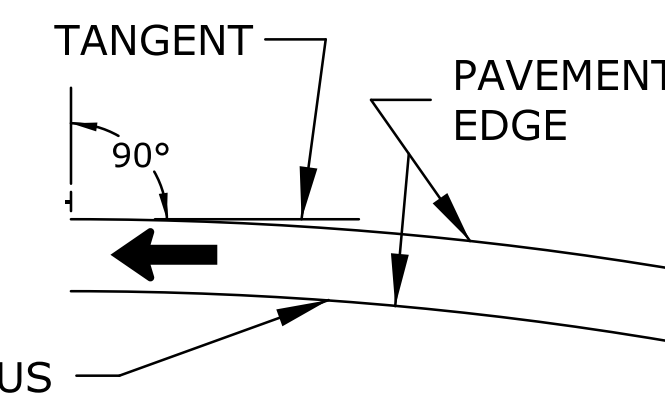

RADIUS GREATER THAN 525 FT

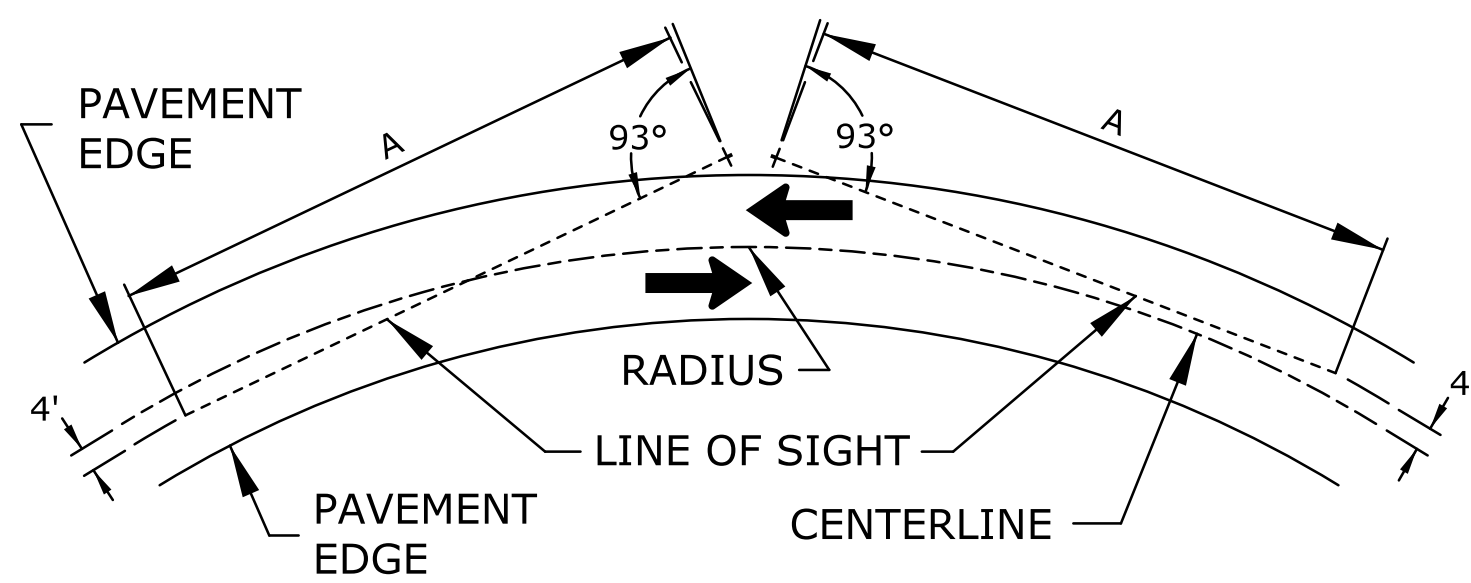

RADIUS LESS THAN 525'

RADIUS (FT)	A (FT)
300 - 525	200
125 - 300	100
LESS THAN 125	*

* DISTANCE DETERMINED BY ENGINEER

TWO-WAY TRAFFIC

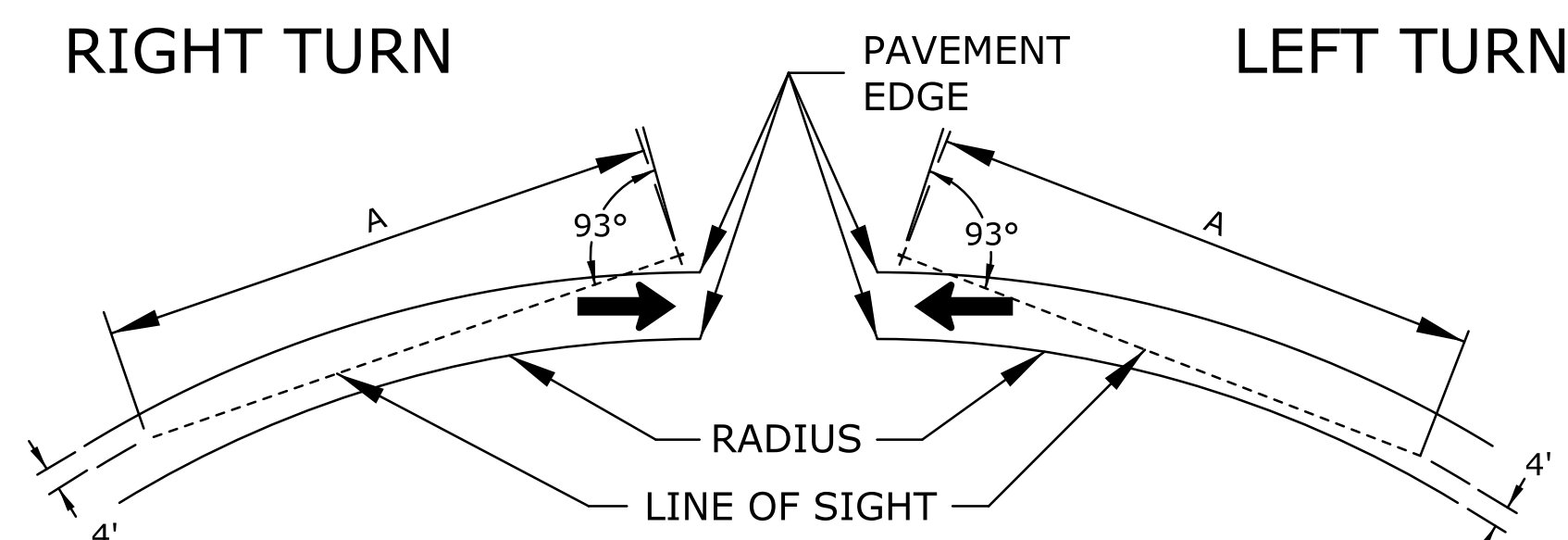

RADIUS LESS THAN 500 FT

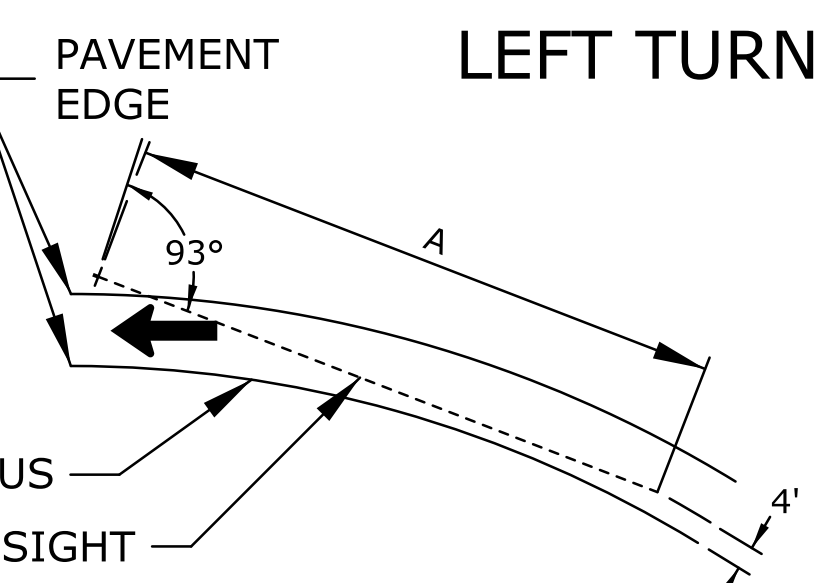

RADIUS LESS THAN 525 FT

RADIUS (FT)		A (FT)
RIGHT TURN	LEFT TURN	
330 - 500	300 - 525	200
140 - 330	125 - 300	100
LESS THAN 140	LESS THAN 125	*

* DISTANCE DETERMINED BY ENGINEER

ONE-WAY TRAFFIC

POSITIONING ANGLE FOR CHEVRON (W1-8 SIGN)

GENERAL NOTES:

CHEVRONS LOCATED BETWEEN 100 FEET IN ADVANCE OF AND 50 FEET BEYOND THE NOSE OF THE GUARD FENCE SHALL BE ELIMINATED

Drawn By : djb
 Plotted : 27-DEC-2013 14:02
 File : I:\2009\09521\Standards\09521-TE418.dgn

NO.	DATE	REVISIONS	BY	APP'D

KANSAS DEPARTMENT OF TRANSPORTATION

POSITION DETAILS FOR CHEVRON (W1-8) SIGNS

TE418 7/1/03

FHWA APPROVAL	7/22/2003	APP'D	Steven A. Buckley
DESIGNED	D.D.G.	DETAILED	W.S.B.
DESIGN CK.	S.A.B.	DETAIL CK.	D.D.G.
		QUANTITIES	TRACED
		QUAN. CK.	TRACE CK.