

GENERAL NOTES:

1. Contractor will be required to provide notice to utility companies a minimum of twenty-four (24) hours prior to any excavation, as follows:

Kansas One-Call (316)687-2470

The Contractor must notify the following in case of an emergency:

Cox Communications (316)262-4270
or (316)263-2061

Westar Energy/
Kansas Gas & Electric Company (800)482-4950
AT&T 1-555-1212
City of Wichita Water Department (316)268-4908
City of Wichita Sewer Department (316)268-4071
Aquila Natural Gas (316)941-1608
or (800)303-0357

2. Exist. utilities and their locations, as shown on the plans, represent the best information obtainable for design. Location information has been obtained from the various utility companies and is either from company record drawings or company-provided field locations. The Contractor will be required to work around existing utilities which do not conflict with proposed constructions.

3. The Contractor to verify utility locations prior to construction of this project.

4. Utility service and installation shall be coordinated with the respective utility owner. Contacts are:

Kansas Gas Service	Jim Coe	(316)832-3126
Westar Energy	Miles Capps	(316)261-6251
Aquila Networks	Calvin Briggs	(316)942-8811
Wichita Water & Sewer	Kerry Gibson	(316)268-4555
AT&T	Jim Toben	(316)268-2759
Cox Communications	Mark Anaya	(316)262-4270

5. All lawn/turf areas disturbed by construction of proposed improvements shall be restored with the same grass as existing. Restoration of disturbed areas shall include, but not limited to, soil preparation, fertilizing, seeding, mulching (all seeded areas, outside the limits of erosion mat placement), and/or reseeding, and installation of erosion control mat. All seeding work shall be in accordance with the City of Wichita Standard Specifications and the City of Wichita Administrative Regulations No. AR 6.5 which governs cleanup and respiration or replacement following construction. All cost for the soil preparation, seeding and mulching (all seeded areas, outside the limits of erosion mat placement) shall be paid for through the lump sum bid item for "Seeding." All seeded areas within eight feet of the back of new curb shall be covered with an approved erosion mat, which shall be paid for by the measured quantity bid item "Back of Curb Protection (8' wide)."

6. Traffic affected by the construction of this project shall be handled in accordance with the latest edition of the Manual on Uniform Traffic Control Devices.

7. It is the contractor's responsibility to visit this site to better understand the extent of site clearing and restoration to be performed. Site Clearing and Restoration shall include all costs for removal of items which a pay item is not provided.

8. The contractor shall be responsible for preserving property irons. The contractor will be required to re-establish any property irons which are damaged or destroyed by the construction operations. Such irons shall be re-established by a licensed land surveyor in accordance with state laws.

9. Properties within the project limits may have underground sprinkler systems in public right-of-way which conflict with new construction. Contractor will be required to remove such improvements should they not be removed by their owner at the time of construction of the project. The contractor will be required to salvage all sprinkler heads and/or valves and give such material to owner. Portions of underground sprinkler systems not in conflict with new construction shall be protected from damage and shall remain in place. All work in connection with underground sprinkler systems shall be considered as subsidiary to the contract pay items for work.

10. Cuts made in paved surfaces on public property will be repaired by the City's Contractor and charged against the contractor. Unit Repair prices are available from the city at 268-4418. A surcharge may be applicable. Call 268-4418 for details. Repair costs to be paid prior to release of utility service if utilities are effected.

FIRE SERVICE LINE TO SERVE ALLISON MIDDLE SCHOOL

221 S. SENECA

1635 PPW (607853)

CITY OF WICHITA, KANSAS

Jim Armour, P.E., City Engineer

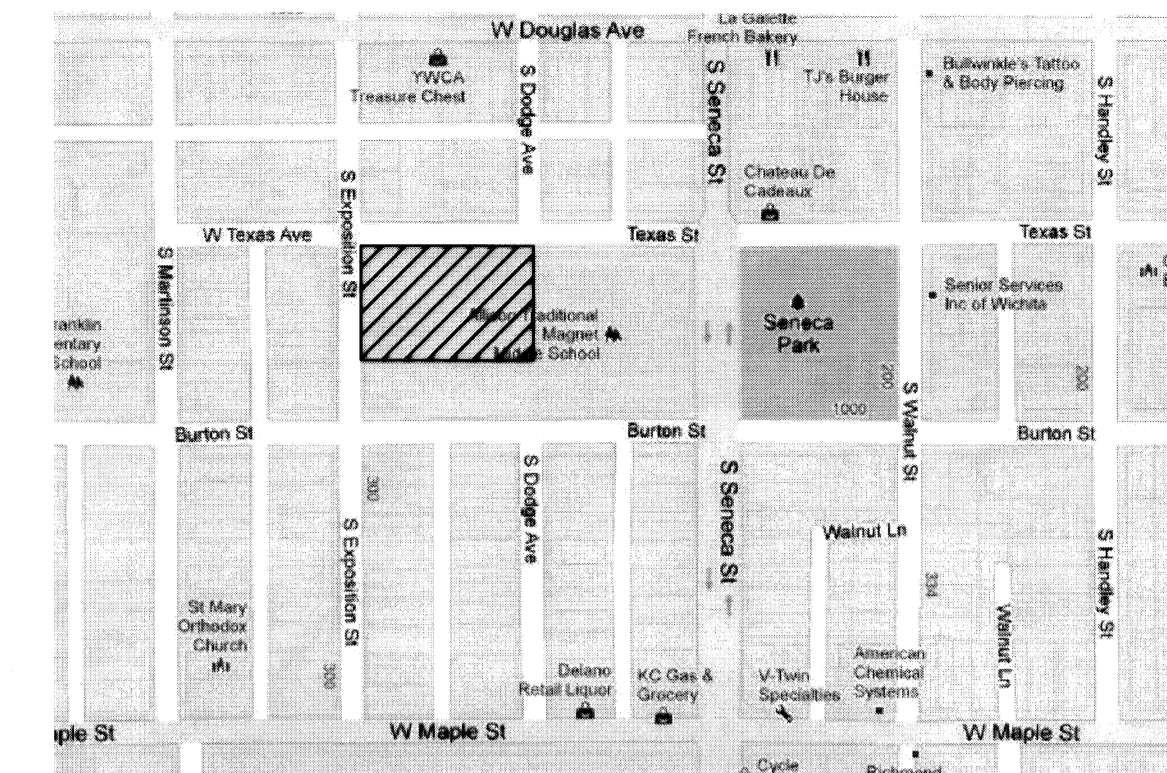

LOCATION MAP
(For Visual Use Only)

Index of Sheets:

- 1.0 Cover Sheet
- 2.0 Plan & Profile
- 3.0 Water Details
- 4.0 Plat

Benchmark:

Square Cut on top of curb. 128' South and 14.5' West of the Northwest Corner of Lot 14, Lawrence's 5th Addition
Elev. = 1298.94 (NAVD 88)

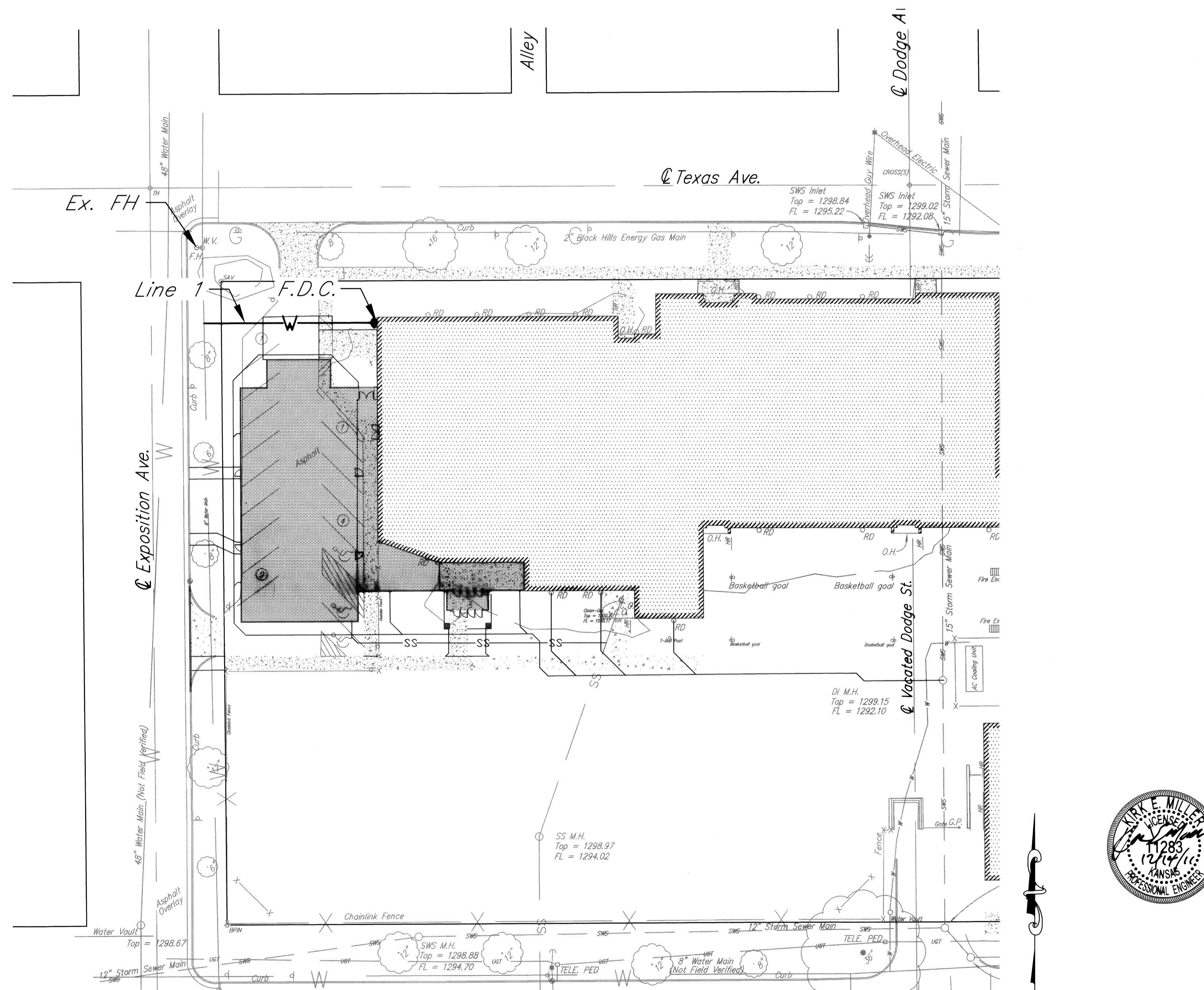

APPROVED AS NOTED
BY CITY ENGINEER OF WICHITA,
BY WICHITA WATER & SEWER DEPARTMENT,
& BY WICHITA FIRE DEPARTMENT

Public Works *Johanna Kellman* 12-19-11
Water & Sewer *Drew Haly* 12-20-11
Fire *Drew Haly* 12-20-11

NOTE TO CONTRACTORS
Public Property:
Inspection and testing for the waterline is to be provided by a Licensed Consulting Engineering Firm under contract with the Owner/Developer. Said inspection to be in accordance with the City of Wichita standard construction engineering practices and certified by a Professional Engineer Licensed in the state of Kansas. No work shall be performed in dedicated easements or public right-of-way by the Contractor without written authorization by the City Engineer. All Construction and Materials shall comply with the City of Wichita Specifications and Standards (on file and available in the City Engineer's Office).
Private Property:
Installation and testing for the fire protection line is to be performed by a City of Wichita licensed fire protection contractor in accordance with the fire codes as adopted by the City of Wichita. All material and construction practices for the fire protection line shall comply with the fire codes as adopted by the City of Wichita (available from the City of Wichita Fire Department). The Contractor shall not commence work without notification and approval of the Wichita Fire Department. Inspection of the fire protection line is to be provided by a Licensed Engineering Firm under contract with the Owner/Developer and the Fire Department. The contractor shall not start work until the project inspector is assigned to the project and present on the site. Any work done without inspection will be required to be uncovered for inspection.

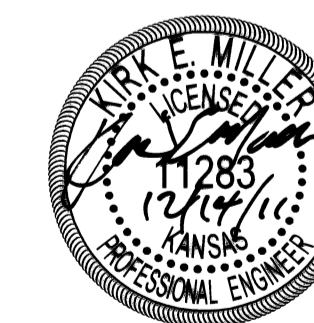

December 2011

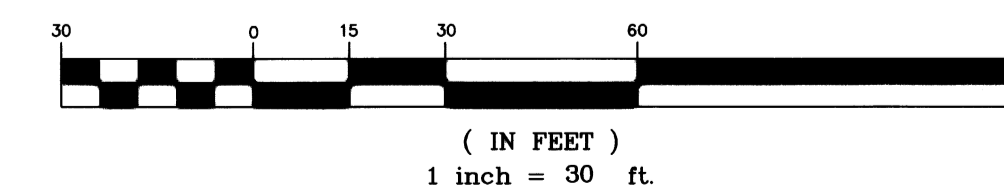

516 S. Market
Wichita, KS 67202 (316)264-0242

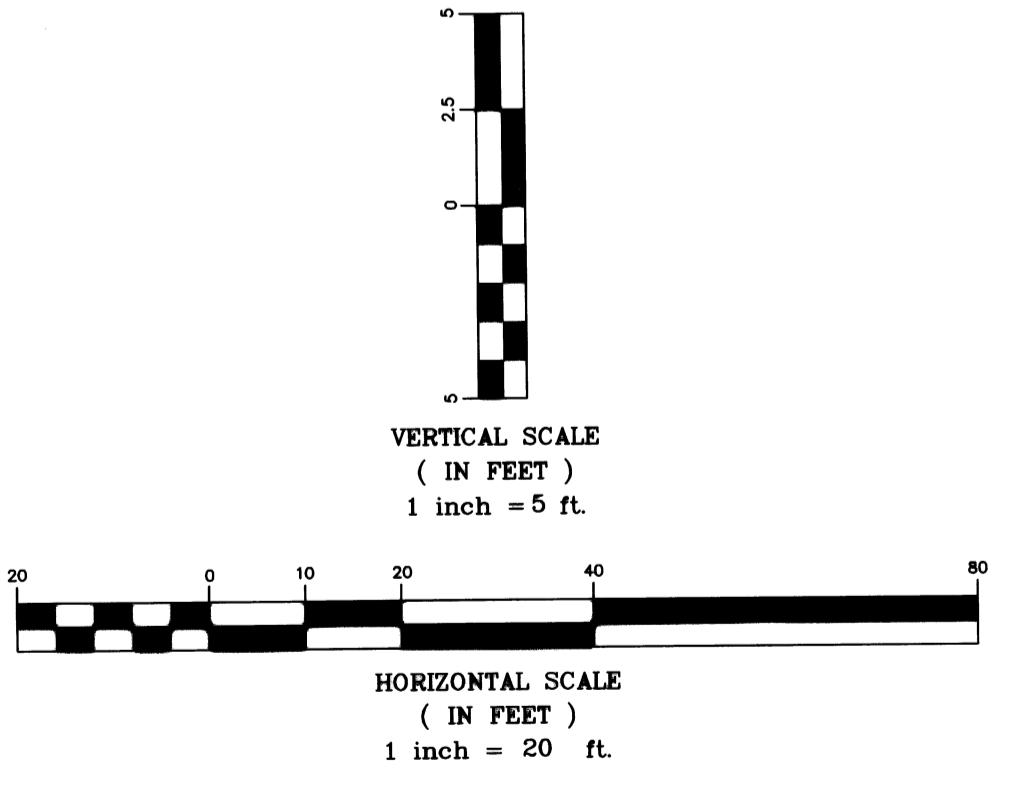
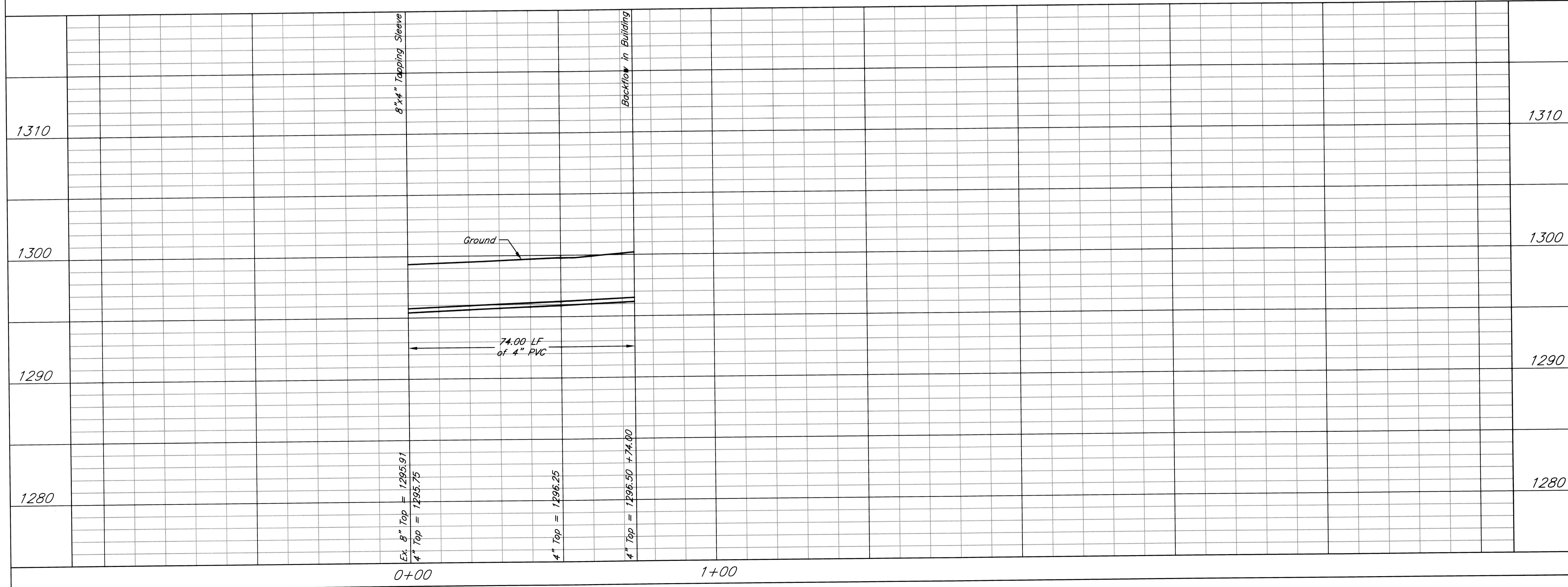
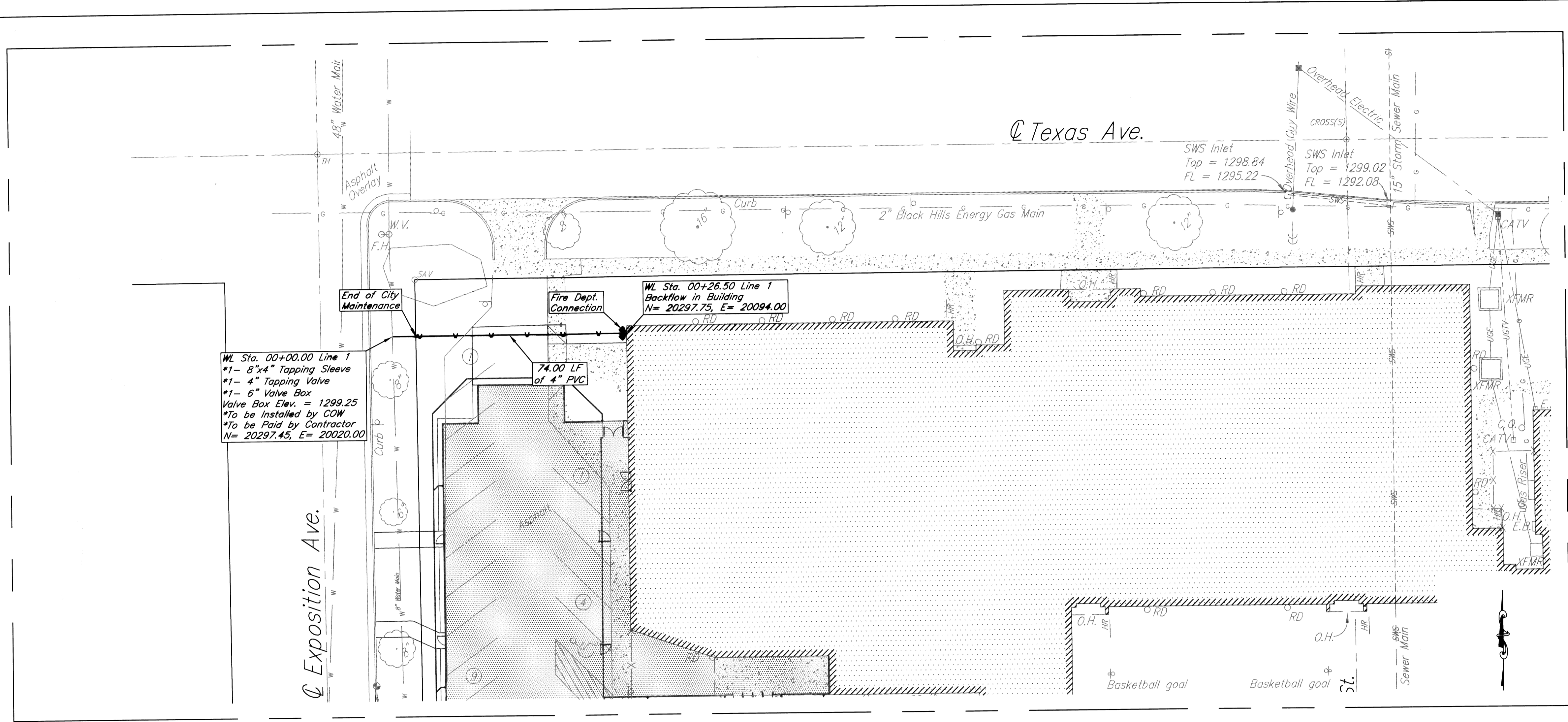

**Allison Middle School
Plan & Profile
Wichita, Kansas**



PROJECT NUMBER			
KEM NO. 11101	FILE	DATE 12/06/11	SHEET 2.0
DESIGN KM	DRAWN NS	REVISED	

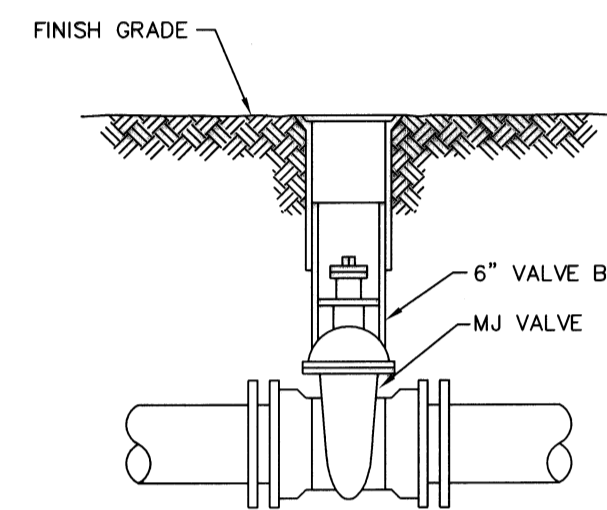

MATERIALS LIST
 1-MJ GATE OR BUTTERFLY VALVE (AS PER PLAN)
 1-6" VALVE BOX
 CONCRETE SUPPORT BLOCK SHALL BE FULL WIDTH OF THE TRENCH

LINE VALVE ASSEMBLY

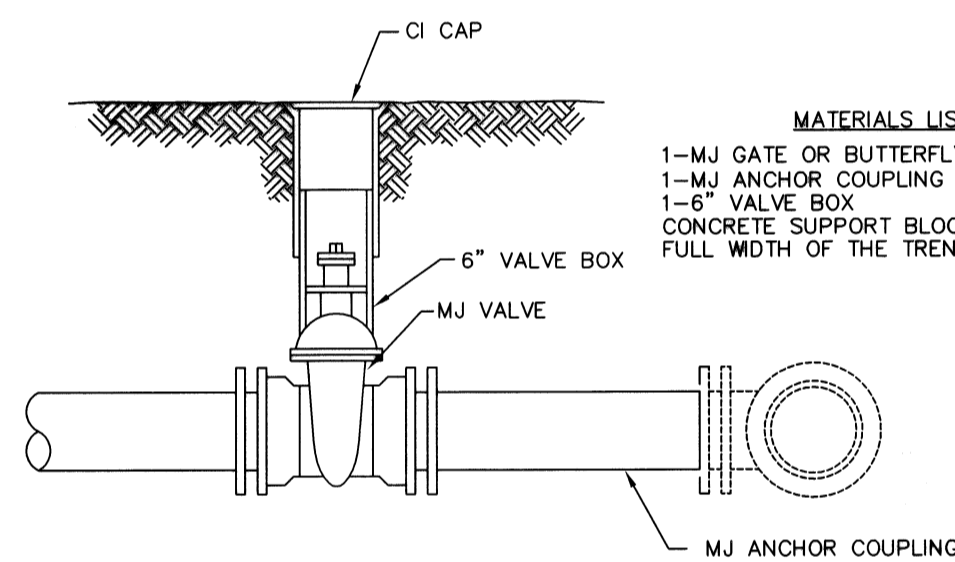

MATERIALS LIST
 1-MJ GATE OR BUTTERFLY VALVE (AS PER PLAN)
 1-MJ ANCHOR COUPLING (12" OR SMALLER)
 1-6" VALVE BOX
 CONCRETE SUPPORT BLOCK SHALL BE FULL WIDTH OF THE TRENCH

ANCHORED VALVE ASSEMBLY

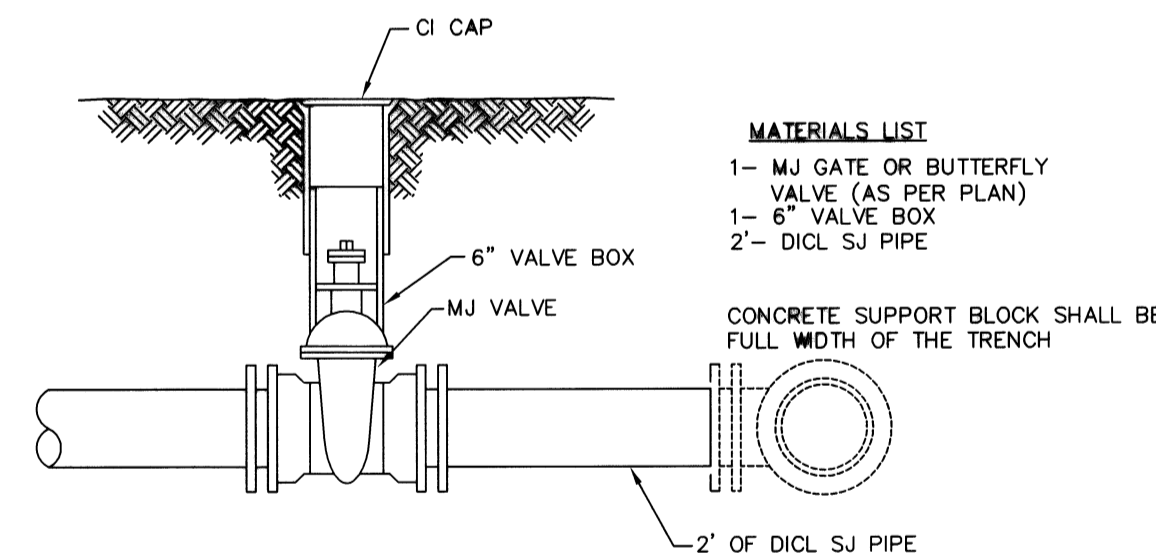

MATERIALS LIST
 1-MJ GATE OR BUTTERFLY VALVE (AS PER PLAN)
 1-6" VALVE BOX
 2'- DI CL SJ PIPE
 CONCRETE SUPPORT BLOCK SHALL BE FULL WIDTH OF THE TRENCH

VALVE ASSEMBLY

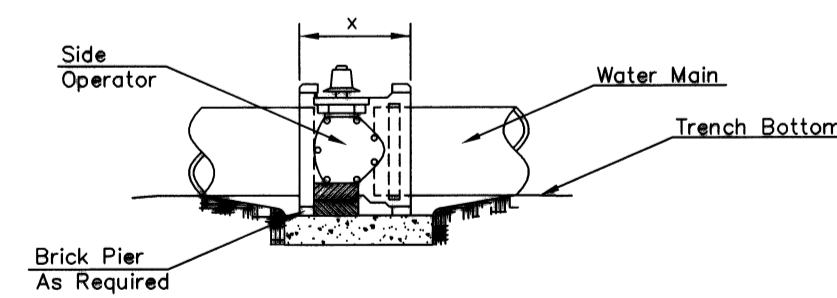

NOTES

- This detail covers Butterfly Valve installation, inclusive, regardless of type of pipe or joint used. Larger lines to be detailed on plans.
- 6" Valve Box and Cover required per City of Wichita Std. Specifications.
- Conc. Support Block to be full width of trench.

CONCRETE SUPPORT BLOCKING FOR BUTTERFLY VALVE INSTALLATION

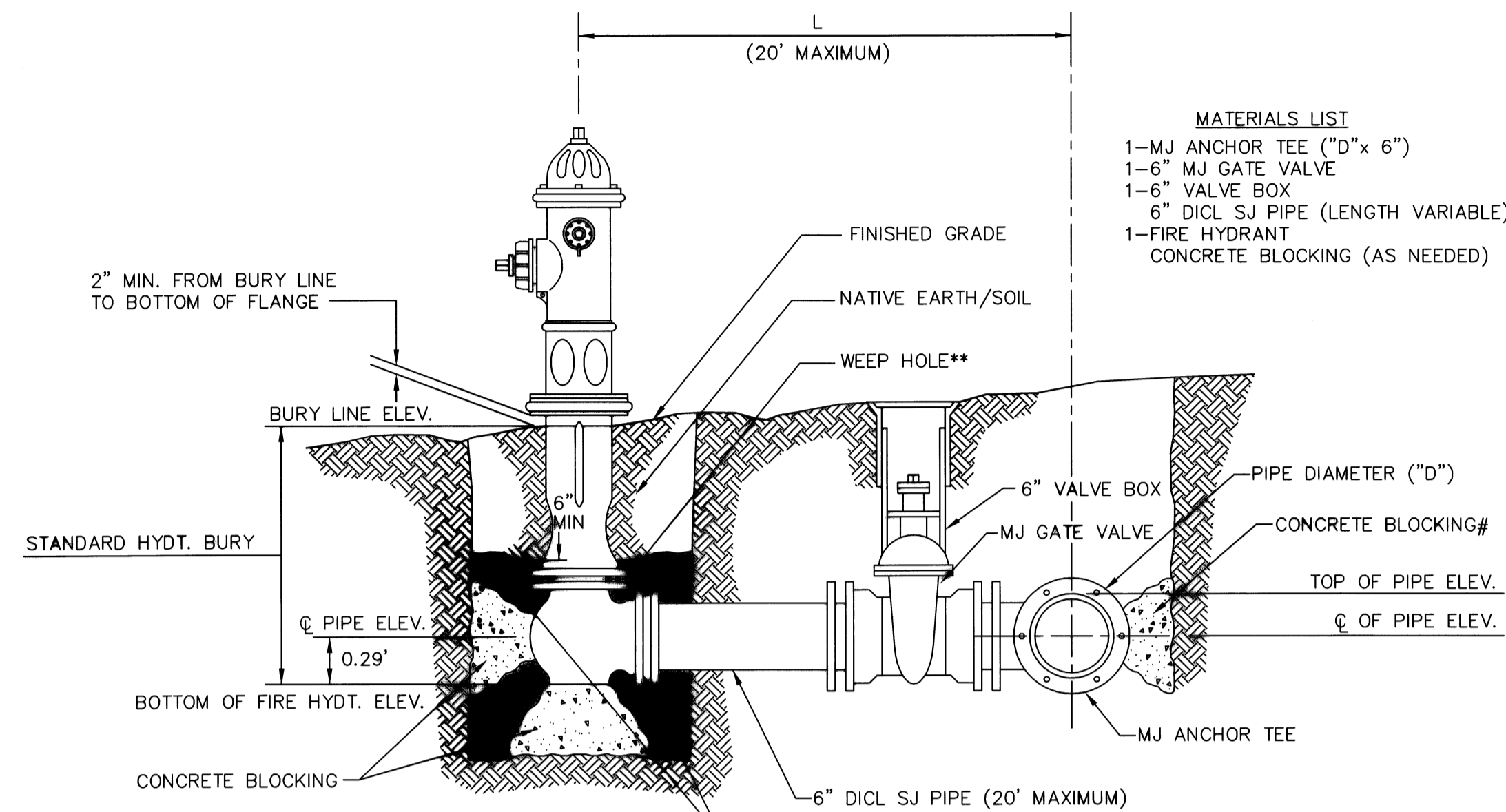

MATERIALS LIST
 1-MJ ANCHOR TEE ("D"x 6")
 1-6" MJ GATE VALVE
 1-6" VALVE BOX
 6" DI CL SJ PIPE (LENGTH VARIABLE)
 1-FIRE HYDRANT
 CONCRETE BLOCKING (AS NEEDED)

** CAUTION! WEEP HOLES TO BE KEPT CLEAR DURING CONSTRUCTION AND BACKFILL. CONCRETE FOR THRUST BLOCKING SHALL NOT OBSTRUCT WEEP HOLES.
 # CONCRETE THRUST BLOCKING SHALL BE KEPT CLEAR OF BOLTS, NUTS, AND MJ ACCESSORIES.

* IF HYDRANT BURY IS IN EXCESS OF 5', CONTRACTOR SHALL USE STANDARD 5" HYDRANT BURY AND HYDRANT BARREL EXTENSIONS AS NECESSARY.

MINIMUM 1 CU. FT. PER WEEP HOLE

PEA GRAVEL ## GRADATION REQUIREMENT	
SIEVE SIZE	SPECIFICATION % RETAINED
3/4"	0 - 5
1/2"	5 - 35
3/8"	40 - 85
# 4	95 - 100
# 8	97 - 100

FIRE HYDRANT ASSEMBLY
 PER CITY OF WICHITA SPECIFICATIONS

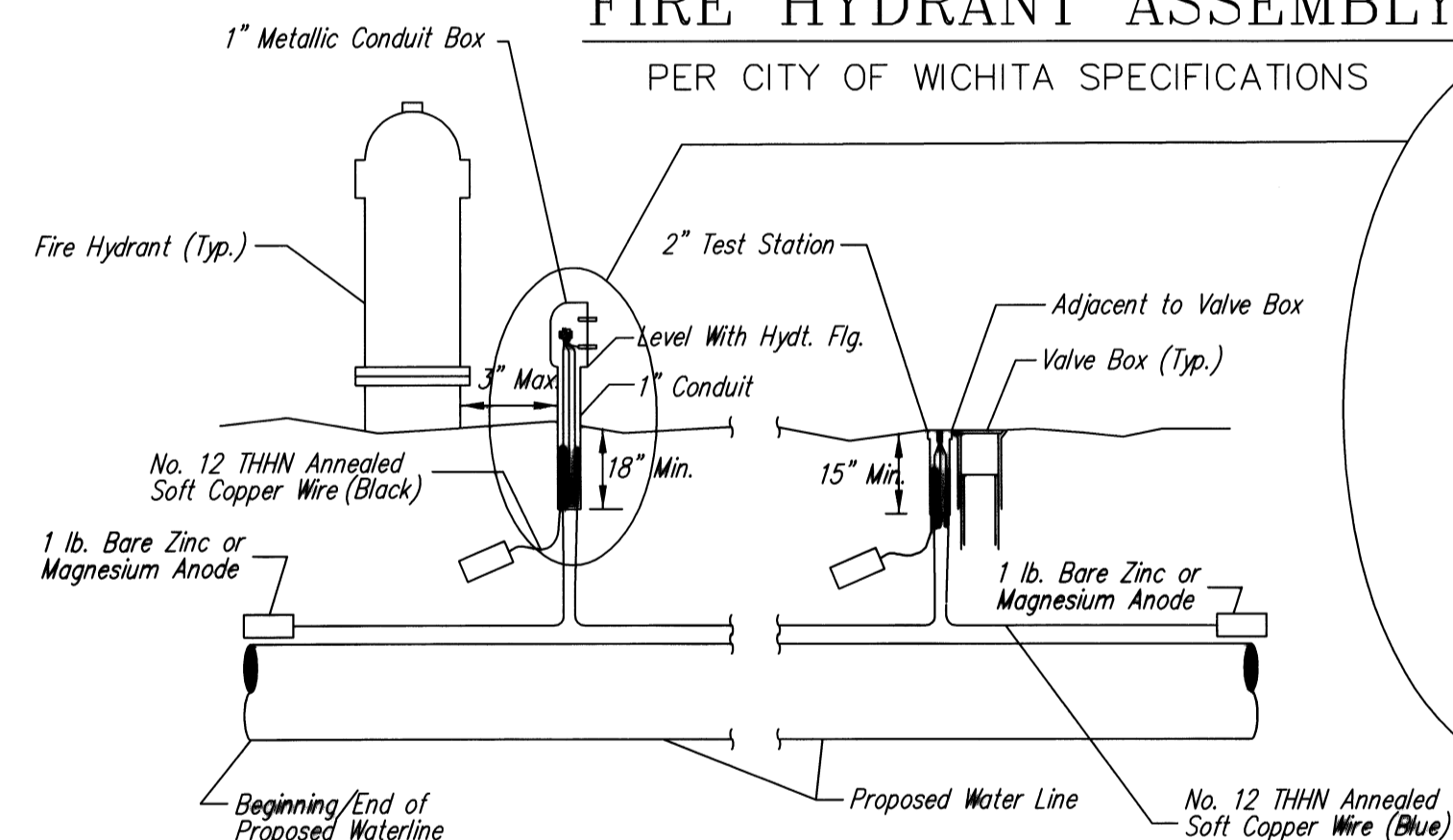

TRACER WIRE

Conductive type pipe locator/tracer wire shall be installed to locate all waterline pipe regardless of pipe material. The wire shall extend the entire length of the proposed pipe. The wire shall be taped to the waterline and pulled with the pipe. Split-bolt connectors shall be used at splice locations. Electrical tape shall cover all splices so no bare wire is exposed. Test stations shall be installed adjacent to all fire hydrants along the waterline and at blowoffs or valves near the ends of the waterlines. Any exceptions to the location of test stations shall be approved by the engineer. At each test station, the tracer wire shall be connected to a 1 lb. Zinc or magnesium anode. Anodes shall also be attached to the tracer wire at both the beginning and the end of the proposed waterline. A typical layout of the tracer wire and test station is provided in the above figure.

WIRE

The tracer wire shall be Blue No. 12 THHN annealed soft copper wire with thermal plastic insulation. The insulation shall be heat, oil, and gasoline resistant as manufactured by Temple Electric or approved equal. To allow for grade adjustment, a minimum of 12" of excess wire shall be coiled at the bottom of the test station for all wires. The insulation sheathing shall be removed such that 1" bare copper wire is exposed at all points of connection. Contractor shall attach wire being installed with proposed water main to any tracer wire installed with adjacent waterline projects.

TEST STATIONS

The test station for fire hydrant applications shall be a 1 inch galvanized conduit style test station as manufactured by AGRA Industries with a removable solid cover having two leads extending from the face or approved equal. The test station for valve applications shall be 2 inch flush style test station 12PS3B as manufactured by HANDLEY Industries or approved equal. The conduit style shall be attached to a 1 inch rigid galvanized conduit with a minimum length of 36" and plastic end bushing. The flush style shall have the word "WATER" stamped or molded into the lid. All test stations shall be manufactured using molded blue tops or sufficiently coated with blue enamel paint. The tracer wire and the anode wire shall be installed to allow 10 inches of wire within the test station. In concrete environments such as sidewalks or in the downtown area the contractor shall use the flush style test station. The location of all test stations shall be approved by the engineer, recorded, and shown in the as-built drawings.

ANODES

The anodes shall be 1 lb. bare zinc or magnesium. The anodes shall be buried at the same elevation as the waterline at each test station. The anodes shall be connected to Black No. 12 THHN annealed soft copper wire which shall be extended to the test station.

TRACER WIRE DETAIL

COST IS SUBSIDIARY TO PIPE INSTALLATION

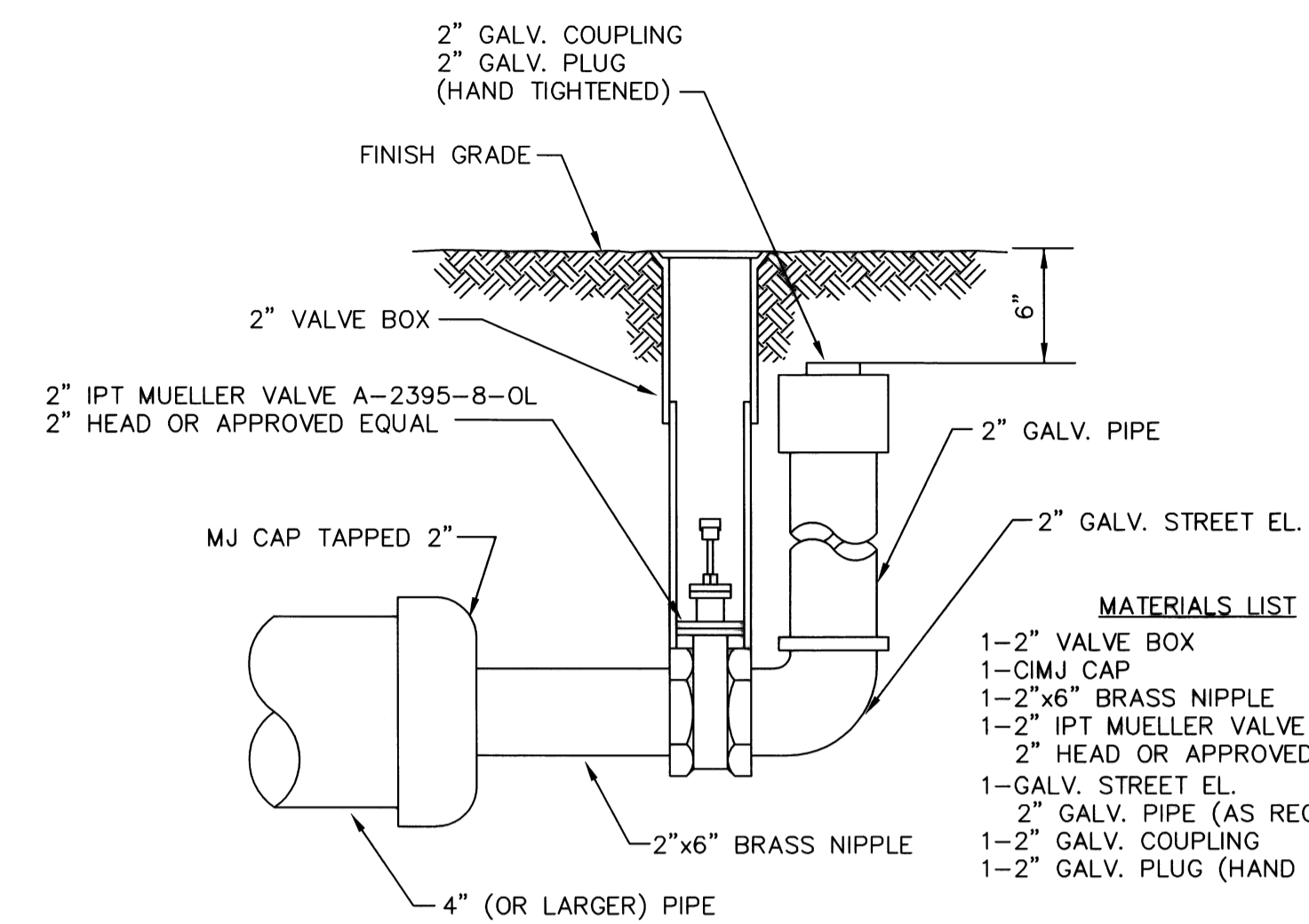

MATERIALS LIST
 1-2" VALVE BOX
 1-CIMJ CAP
 1-2"x6" BRASS NIPPLE
 1-2" IPT MUELLER VALVE A-2395-8-OL
 2" GALV. PIPE (AS REQUIRED)
 1-2" GALV. COUPLING
 1-2" GALV. PLUG (HAND TIGHTENED)

2" BLOWOFF ASSEMBLY

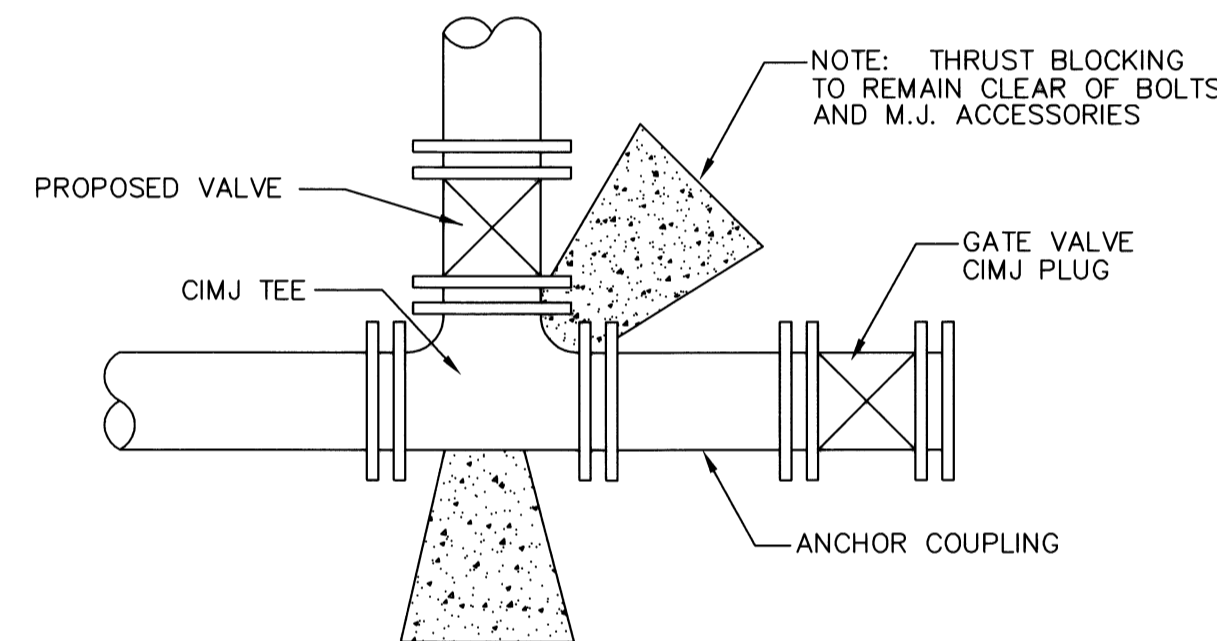

KEY BLOCK DETAIL

2 Blue Wires and 1 Black Wire All Connected to Single Test Lead With Split Bolt Connection and Blue No. 12 THHN Annealed Soft Copper Wire

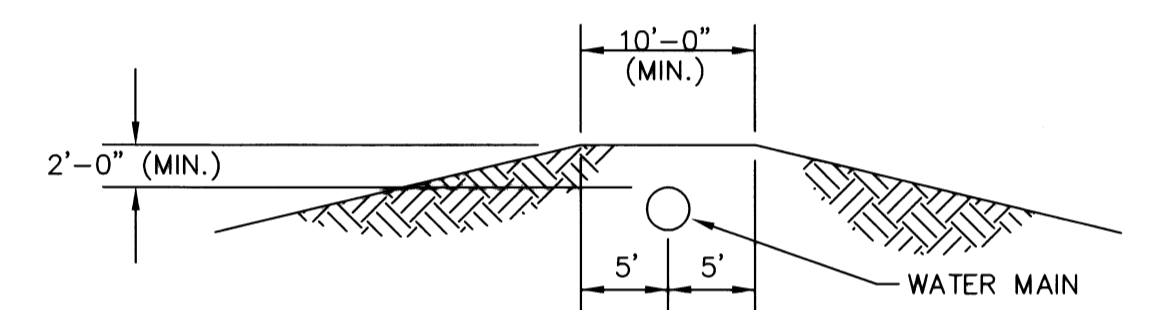

PROTECTIVE FILL DETAIL

MINIMUM PROTECTIVE FILL SHALL BE PROVIDED IN ALL INSTANCES WHERE COVER OVER THE PROP. WATER LINE IS LESS THAN (2) FEET. (COST SUBSIDIARY TO PIPE INSTALLATION)

FIRE HYDRANTS REQUIRED			
STATION	BURY LINE ELEVATION	TOP OF PIPE ELEVATION	FIRE HYDRANT BURY REQUIRED*



	STANDARD WATER ASSEMBLY DETAILS		
	CITY ENGINEER JAMES L. ARMOUR, P.E., L.S.		
	PROJECT NUMBER	OCA NUMBER	DATE 12/2011
CITY ENGINEER'S OFFICE CITY HALL - SEVENTH FLOOR 455 NORTH MAIN STREET WICHITA, KANSAS 67202-1620 (316) 268-4501 (316) 268-4114 FAX			SHEET 3.0

REV: 8-14-01, MCG

